

# Level 2 Certificate in Basic Plumbing Studies

# Level 3 Certificate in Domestic Plumbing Studies

Application of Practical Tasks –  
Requirements for Centres –  
Plumbing Certificates Level 2 & 3  
6129 Scheme

## **Contents**

**Page**

- |           |   |           |
|-----------|---|-----------|
| <b>1.</b> | <b>General Requirements for Centres</b>                           | <b>3</b>  |
| <b>2.</b> | <b>Summary of Level 2 Task Activities and Timings</b>             | <b>8</b>  |
| <b>3.</b> | <b>Application of Level 2 Practical Task Assessments</b>          | <b>11</b> |
| <b>4.</b> | <b>Summary of Level 3 Task Activities and Timings - Gas Route</b> | <b>31</b> |
| <b>5.</b> | <b>Application of Level 3 Practical Tasks – Gas Route</b>         | <b>32</b> |

### **Northern Ireland Centres Only**

- |           |   |           |
|-----------|---|-----------|
| <b>6.</b> | <b>Summary of Level 3 Task Activities and Timings - Oil Route</b> | <b>39</b> |
| <b>7.</b> | <b>Application of Level 3 Practical Tasks – Oil Route</b>         | <b>40</b> |

## **1. General Requirements for Centres**

### **Aim of the Document**

To provide detailed requirements to approved centres on the application of the practical task assessments for the scheme.

### **General Points**

#### **Application of Candidate Practical Task Assessments**

Each candidate must be registered on the scheme within 8 weeks of commencing the programme of learning and assessment.

The candidate must undertake and successfully complete all of the practical tasks contained in the Practical Task Manual. The Awarding Body has laid down specific maximum timescales within which each practical activity must be carried out. These timescales must be strictly adhered to. If after two attempts the candidate has not successfully achieved the scheme standards it is expected that the candidate will go back to the beginning of the task and commence from the beginning, with the exception of the full installation activities carried out (bathroom, airing cupboard and central heating system) during which it is anticipated that any installation defects brought about by the candidate in the installation process will be remedied during the installation process.

The practical tasks undertaken by candidates must be the individual candidate's own work, it is not permissible for candidates to receive support from fellow candidates in undertaking the tasks (unless specifically identified in the practical task manual). Candidates may request information from scheme assessors regarding the tasks to be undertaken, it is not permissible for scheme assessors to undertake any of the practical activities supporting the tasks.

#### **Recording the Outcomes of the Practical Task Assessments**

The Practical Task Manual contains all of the exercises necessary to meet the 6129 scheme standards. The manual contains all of the necessary candidate recording sheets which require counter-signature and dating by both the assessor and candidate. Several practical tasks require the production of a materials schedule which should be produced by the candidate on a separate sheet of paper and should be inserted in the manual at the appropriate point. Further guidance is provided later in this guidance note. At various points in the task schedule the candidate is required to produce supplementary evidence. The production of this supplementary evidence is a mandatory requirement of the scheme.

#### **External Verification of Practical Tasks – Scheme 6129**

Provision will be made by the Awarding Body to undertake specific verification visits related to the scheme. Your External Verifier will liaise with the Scheme Co-ordinator to arrange an appropriate date/ time for visits so that a number of candidates can be observed carrying out a selection of practical assessment activities on the day of the external verification visit. External Verifiers will select the practical activities they wish to observe taking place on a sampling basis. Approved centres are required to fully co-operate with their External Verifier at all times during the external verification process.

## **Internal Verification of Practical Tasks – Scheme 6129**

The centre is required as part of the scheme criteria to implement effective internal verification measures as it's own quality check on assessment procedures. The internal verification of practical tasks for the scheme must include sampling across all the range of candidate practical task activities. The centre is required to produce their own recording procedures for detailing internal verification activities.

### **Sanitary Appliance Jigs**

It is acknowledged by the Awarding Body that centres may not be able to provide the sanitaryware required for all candidates to undertake all of the practical tasks listed. It is therefore permissible for the centre to produce an appropriate jig/ bracketing arrangement to simulate the connection of pipework to tap assemblies, traps to wastes etc. When producing the jig/ brackets for the tasks, the centre should ensure that the dimensions simulated are based on typical sanitaryware dimensions. Sanitary appliance jigs can only be applied to the following task activities –

#### **Level 2**

- Copper tube range (CT)
- Appropriate plastic pipework tasks (PP)

### **Testing of Installation Models**

Testing of simple installation models for water leakage is by procedures which are not fully 'in line' with the requirements of the Water Supply (Water Fittings) Regulations 1999, this is to permit the centre to apply testing procedures on an economic basis. All full installation exercise must be fully tested to meet the requirements of the Water Supply (Water Fittings) Regulations 1999.

### **Installation surfaces**

The installation surfaces to which the work activities must be carried out are generally specified with the exception of the smaller Level 2 tasks. The simpler pipework activities detailed in the Level 2 award may be carried out on timber surfaces, these must however be rigidly fixed to ensure a firm work surface for the candidate.

### **Practical Workshop Resources**

#### **A General Layout**

The workshop should be adequate in size for the number of candidates and not constitute a hazard to health and safety whilst practical task activities are being carried out.

#### **B Position of Equipment**

Benches and fixed equipment should be positioned to provide a clear and unobstructed working area, which will permit easy access in case of emergency. A passageway of one metre minimum width should be maintained between rows of benches; but where persons are working back to back between benches the space should not be less than 1.5 metres.

## C Cleanliness

It is important that the workshop is kept clean and tidy; if sited upon a concrete floor, this should be sealed against dust.

## D Storage Facilities

The materials store should be adjacent to the workshop. This must be suitably fitted out with shelving and racks, which should ensure that tools and materials are stored in a safe and organised manner with adequate stock available and in good condition.

**Note: Centres using flammable liquids and low-pressure gases must take particular account of the special requirements needed to store these items safely. (BS 5482 Part 1, BS 1463 Para 6.3.4 and/or current British Standards and legislation).**

## E Electrical Supplies

Supplies up to and including mains voltages are permitted in the training area where these are essential for the purpose of energising training circuits. The installation of these supplies shall comply with the following: -

- The mains supply shall be terminated in each cubicle using a consumer unit supplied via a lockable isolator, fixed to the wall, at a suitable height from the floor.
- Each will be fed via an individual MCB contained within a distribution board, which has a lockable lid.
- All circuits will have the protection of a 30mA residual current device.
- All supplies within the training area will be protected by an emergency stop circuit. This will be operated by suitably placed self-latching stop buttons. All emergency stop buttons will be identified using a British Standard sign. (General lighting circuits are excluded from the emergency stop circuit).
- Suitable "Power on" visual indication is required to clearly show when individual cubicle supplies are energised.
- When workshop areas are split between locations, an audible alarm system should be installed which will bring the operation of an emergency stop button to the assessors attention. This alarm should also identify the location of the operated button.

## F Reduced Voltage Supplies

A 110-volt supply is also required for portable tools; it is desirable that this be provided via permanently wired industrial sockets placed adjacent to the point of usage. Trailing leads are **NOT** permitted in the workshop area.

## **G Sheet Leadwork**

Sheet lead welding must be conducted on benches which incorporate a mechanical extraction ventilation system to minimise to the lowest possible level the risk of lead fume inhalation, or alternatively sheet lead welding activities must be carried out external to the building.

## **H Workshop Equipment**

The approved centre must provide full resources to permit all the practical activity tasks to be completed including –

- Material & fittings
- Plumbing equipment (to a commercially acceptable standard)
- Tools and equipment

## **Safety**

The need for candidates to wear appropriate clothing whilst in workshops or project areas cannot be over-emphasised. Candidates should wear overalls and safety shoes. Safety hats should be worn when working in any site simulation area; these areas should be designated as hard hat areas and appropriate signs displayed. All other items of Personal Protective Equipment (PPE) shall be provided and worn as appropriate. It is the responsibility of the centre to ensure that PPE is provided and worn.

## **A Risk Assessments**

The centre shall have conducted suitable and sufficient risk assessments as required by the Awarding Body for all the practical tasks that form the programme.

## **B Statutory Notices**

Adequate wall space must be provided within the workshop to ensure that all necessary statutory and advisory notices are prominently displayed adjacent to items/locations to which they refer.

## **C Safety Equipment**

Guards shall be fitted and used on all workshop machines. They must be regularly inspected for damage and replaced when necessary. Safety glasses shall be provided adjacent to every drilling machine and threading machine used by candidates. These should be kept in a protective container, to prevent the lenses becoming scratched and dirty.

## **D Trained First Aiders**

Should always be readily available when candidates are present in the workshop. Their names and locations should be prominently displayed in the workshop area.

## **E First Aid Boxes**

These must be provided in the workshop and their contents should comply with the Health and Safety at Work legislation requirements and the current British Standard. A list of contents and an accident record book should be included in, or adjacent to, the box.

## **F Fire Appliances**

A number of fire appliances of the appropriate type must be placed in strategic positions within the workshop and should be suitable for their intended use. It is important that the centre ensures that these are regularly checked by the proper authority and that evidence of inspection is recorded on each appliance.

## **G Fire Exits**

Adequate provision must be made to allow occupants of the workshop to escape in the case of fire. All escape routes must be well lit clearly posted and always remains free from obstruction. All fire exits shall be fitted with proprietary quick release mechanisms and shall, wherever possible, open with the "outward flow" of personnel.

## **H Induction**

It is a mandatory awarding body requirement that a full health & safety induction is provided prior to commencing practical activities (either training or assessment) in the practical workshop.

## 2. Summary of Level 2 Task Activities and Timings

<b>SAFETY</b>		
<b>REF.</b>	<b>TASK COMPETENCE</b>	<b>ALLOCATED TIME</b>
S-1A	Kinetic lifting	45 mins
S-1B	Lifting equipment	20 mins
S-2	Safe use of ladders	60 mins
S-3	Safe use of stand steps	15 mins
S-4	Safe use of mobile scaffolds	90 mins
S-5A	Safe assembly of LPG equipment	20 mins
S-5B	Safe use of LPG equipment	No allocation
S-6	Fire fighting	10 mins
S-7A	Hazardous materials – sheet lead	No allocation
S-7B	Hazardous materials – asbestos	30 mins
S-7C	Hazardous materials – solvents	No allocation
S-8	Working safely with hand tools	30 mins
S-9	Working safely with power tools	20 mins
<b>COPPER TUBE</b>		
<b>REF.</b>	<b>TASK COMPETENCE</b>	<b>ALLOCATED TIME</b>
CT-1	Copper tube – component positions	90 mins
CT-2	Copper tube – fixing positions	60 mins
CT-3	Copper tube – pipe & fitting dimensions	60 mins
CT-4	Copper tube – pipe & fitting dimensions	75 mins
CT-5	Copper tube – marking & cutting	90 mins
CT-6A	Copper tube – machine bending (1)	45 mins
CT-6B	Copper tube – machine bending (2)	90 mins
CT-6C	Copper tube – machine bending (3)	90 mins
CT-7	Copper tube – jointing & testing	2 hours
CT-8	Copper tube – making fixings	75 mins
CT-9	Copper tube – fabrication & installation	8 hours
<b>PLASTIC PIPEWORK</b>		
<b>REF.</b>	<b>TASK COMPETENCE</b>	<b>ALLOCATED TIME</b>
PP-1	Soil & waste – pipe & fitting dimensions	90 mins
PP-2	Soil & waste – fabrication & installation	7 hours
PP-3	Rainwater system	5 hours
PP-4	Pressure pipe – pipe & fitting dimensions	75 mins
<b>AIR TESTING</b>		
<b>REF.</b>	<b>TASK COMPETENCE</b>	<b>ALLOCATED TIME</b>
AT-1	Air test – soil pipe	30 mins

**LOW CARBON STEEL (LCS)**

REF.	TASK COMPETENCE	ALLOCATED TIME
SP-1	LCS – pipe & fitting requirements	90 mins
SP-2	LCS – component positions	60 mins
SP-3	LCS – fixing positions	60 mins
SP-4	LCS – pipe & fitting dimensions	75 mins
SP-5	LCS – marking & cutting	2 hours
SP-6A	LCS – machine bending (1)	75 mins
SP-6B	LCS – machine bending (2)	45 mins
SP-7	LCS – jointing & testing	3 hours
SP-8	LCS – fabrication & installation	14 hours

**SHEET LEAD WEATHERING**

REF.	TASK COMPETENCE	ALLOCATED TIME
SW-1	Sheet lead – identifying components	30 mins
SW-2	Sheet lead - measuring components	2 hours
SW-3	Sheet lead – cutting lead	45 mins
SW-4	Sheet lead – forming components	2 hours
SW-5	Sheet lead – lead slate	3 hours
SW-6	Sheet lead – chimney weathering set	14 hours
SW-7	Basic maintenance	75 mins

**AIRING CUPBOARD INSTALLATION**

REF.	TASK COMPETENCE	ALLOCATED TIME
AC-1	Airing cupboard – storage cistern	7 hours
AC-2	Airing cupboard – hot water cylinder	

**BATHROOM INSTALLATION**

REF.	TASK COMPETENCE	ALLOCATED TIME
BI-1	Bathroom – WC suite	28 hours
BI-2	Bathroom – bath	
BI-3	Bathroom – basin	
BI-4	Bathroom – radiator	
BI-5	Bathroom – combi jig	

**DECOMMISSIONING**

REF.	TASK COMPETENCE	ALLOCATED TIME
DC-1	Decom – hot & cold water system	2 hours
DC-2	Decom – sanitation system	2 hours

<b>ROUTINE MAINTENANCE</b>		
<b>REF.</b>	<b>TASK COMPETENCE</b>	<b>ALLOCATED TIME</b>
RM-1	Maintenance – pillar tap & float valve	30 mins
RM-2	Maintenance – shower mixer valve	40 mins
RM-3	Maintenance – radiator valve	40 mins
RM-4	Maintenance – WC siphon	30 mins
<b>ENVIRONMENTAL AWARENESS</b>		
<b>REF.</b>	<b>TASK COMPETENCE</b>	<b>ALLOCATED TIME</b>
EA-1	Economic use of materials	No allocation
<b>TEMPORARY CONTINUITY BONDING</b>		
<b>REF.</b>	<b>TASK COMPETENCE</b>	<b>ALLOCATED TIME</b>
TB-1	Application of temporary earth bonding	30 mins

### **3. Application of Level 2 Practical Task Assessments**

#### **Safety Tasks (S)**

Wherever practicable these activities must be amalgamated with the range of plumbing activities being carried out in the certificate.

##### **Task S-1A**

The centre must have produced a manual handling assessment that the candidate must follow for this activity.

The candidate is required to demonstrate a safe lifting procedure using the kinetic lifting technique. The weight being lifted must fall within the safe lifting range detailed in the Guidance Document to the Manual Handling Regulations.

The assessor must observe the candidate demonstrating the safe lifting procedure to prove competent.

##### **Task S-1B**

The centre must have produced a manual handling assessment that the candidate must follow for this activity.

The candidate is required to move a heavy load with a piece of lifting equipment (typically this will be a sack trolley – suggested roll of sheet lead). The candidate should be observed –

- Checking the item of lifting equipment
- Checking the route along which the load is to be moved for clearance
- Seeking assistance from a colleague to lift the sheet lead on to and off the lifting equipment
- Using the lifting equipment in a safe manner

##### **Task S-2**

The centre must have produced a risk assessment for the safe use of ladders that the candidate must follow for this activity.

The candidate is required to erect a ladder under simulated conditions to gain access to a work platform. The work platform should be situated at least 2 metres above ground level.

Key assessment criteria that the centre assessor should be evaluating are as follows:

- Ladder was long enough to extend above working platform by a minimum of 1 metre
- Ladder was in sound condition e.g. had no cracks, loose rungs or missing support wires
- Ladder was appropriate class for working situation
- Ladder was erected and positioned at an acceptable angle
- Ladder was effectively secured at top, and at bottom (where necessary)

### **Task S-3**

The centre must have produced a risk assessment for the safe use of stand steps that the candidate must follow for this activity.

The candidate is required to select and use stand steps to obtain access to undertake plumbing work. The work to be carried out should require the use of stand steps incorporating over 4 steps.

Key assessment criteria that the centre assessor should be evaluating are as follows:

- Steps were of sufficient height to provide easy access to the work without over reaching or stretching
- Steps were in good condition with no splits in the steps, sides or the top platform and there should be no movement arising from weak joints in their construction
- The stand steps should be erected on a firm and flat base and should be fully opened
- The stand steps (where appropriate) should be secured with rope stays or some other form of stay
- On no account should the candidate use the top step to reach the work area
- The work carried out should be short term duration
- If electrical work is being carried out ladders must be of wooden manufacture

### **Task S-4**

The centre must have produced a risk assessment for the safe erection and use of mobile scaffolds that the candidate must follow for this activity.

- The correct scaffold components are selected for the exercise and the condition of the components is checked
- The candidates may work in pairs for the task
- The scaffold is erected on a firm and level base
- The scaffold is erected using manufacturer recommended procedures
- The scaffold is properly anchored and access to the working platform is provided in accordance with Health & Safety Regulations

### **Task S-5A**

The candidate is required to assemble and ignite LPG heating equipment for the purposes of making a low temperature soldered joint. The candidate should complete the task successfully to the standards detailed in the practical task.

### **Task S-5B**

The centre must have produced a risk assessment for hot work in the vicinity of combustible materials that the candidate must follow for this activity.

The candidate is required to use pre-assembled LPG heating equipment for the purposes of making a low temperature soldered joint in the vicinity of combustible materials. The candidate should complete the task successfully to the standards detailed in the practical task.

### **Task S-6**

Under simulated conditions (no fire actually existing) the candidate is asked to deal with a small fire, the combustion source being Class A material, the fire is in the vicinity of a main electrical fuse box. The candidate should select the appropriate extinguisher from a range of different types of extinguisher. The candidate should then be able to demonstrate the correct use of the extinguisher (without discharging the extinguisher content).

Key assessment criteria that the centre assessor should be evaluating are as follows:

- The candidate can name the classification of fire
- The candidate can select an appropriate extinguisher to deal with the fire in the vicinity of the electrical components
- The candidate can demonstrate the correct use of the extinguisher

### **Task S-7A**

The centre must have produced a risk assessment for the use of sheet lead that the candidate must follow for this activity.

The candidate is required to manually work with sheet lead including lead welding. The candidate should complete the task successfully to the standards detailed in the practical task.

### **Task S-7B**

The centre must have produced a risk assessment for situations in which asbestos is encountered that the candidate must follow for this activity.

- The candidate must successfully identify samples of 3 different types of asbestos from photographs that are shown to him/ her by the assessor
- He/ she should identify the safety control measures applicable for working in the vicinity of such material

### **Task S-7C**

The centre must have produced a risk assessment for using solvents to joint plastic pipework that the candidate must follow for this activity.

The assessor should check for the following:

- The candidate referring to the centre assessment and data instructions on the packaging for detail of the safe application of the solvent
- Awareness that the solvent should be applied in a well ventilated area
- The candidate is aware that over-exposure to the use of the substance is not permissible
- The solvent should be safely and securely stored

### **Task S-8**

The assessor will provide the candidate with 8 different hand tools, of which a minimum of 2 should be defective. He/ she should successfully –

- Name the hand tool
- Identify whether the hand tool is safe to use
- Describe what it is used for in the plumbing industry

### **Task S-9**

The centre must have produced a risk assessment for using a power drill and jig saw that the candidate must follow for this activity.

The candidate must:

- Check the power tool for safe condition (one of the power tools should be outside the date required for PAT testing)
- Identified from the risk assessment data sheet the safe method of working with the power tool
- Demonstrated safe procedures when using the power tool

### **Copper Tube (CT)**

#### **Task CT-1**

The candidate is provided with drawing CT-1 and is provided with appropriate sanitaryware from which he/she can take the required task measurements. Alternatively a manufacturer's catalogue may be used to obtain sanitaryware dimensions.

The candidate records the appropriate sanitaryware details in the chart on Drawing CT-1.

The candidate is then required to mark out the position of the pipework on a suitable board or wall surface.

The candidate should complete the task successfully to the standards detailed in the practical task.

#### **Task CT-2**

The task should be incorporated with task CT-1. The candidate should demonstrate his/ her ability to select appropriate pipe fixings for the task from a range of pipe fixings and mark out the position of the pipe fixings and the fixing requirements of the sanitaryware.

The candidate should complete the task successfully to the standards detailed in the practical task.

### **Task CT-3**

This task should be incorporated with task CT-1&2. The candidate should measure and record the length of pipe required to complete the task with an allowance of 100mm for wastage. A fitting list should be produced for the task which should identify fitting type, manufacturer's catalogue and reference number.

The materials listing and pipe calculation detail should be provided on a separate sheet of paper (in the candidate's own writing together with his/her name and the date of assessment). The sheet should be inserted in the practical task manual after the CT-3 recording sheet.

The candidate should complete the task successfully to the standards detailed in the practical task.

### **Task CT-4**

The candidate is provided with drawing CT-4, he/she should be able to select appropriate fittings for the task and determine the 'x' dimensions of the fittings. Detail of the fitting 'x' dimension should be recorded by the candidate in the chart on drawing CT-4. The candidate should then determine the pipework requirements for the task and complete the remainder of the chart on CT-4.

The candidate should complete the task successfully to the standards detailed in the practical task.

### **Task CT-5**

This task should be incorporated with task CT-4. The candidate should mark and cut the pipe to the required lengths using the pipe cutting methods identified.

The candidate should complete the task successfully to the standards detailed in the practical task.

### **Task CT-6A**

The candidate is provided with drawing CT-6A, he/she should identify the length of pipe required to complete the tasks, and an allowance of no more than 30mm wastage for each task is permissible. The pipe should be cut to length, bend dimensions marked out and machine bent. Any excess material should be removed prior to completion of the task.

The candidate on completion should take final measurements of the pipe and confirm that the task meets the dimensional tolerances specified by placing his/ her initials in the dimension details boxes in the chart on drawing CT-6A.

The candidate should complete the task successfully to the standards detailed in the practical task.

### **Task CT-6B**

The candidate is provided with drawing CT-6B, he/she should identify the length of pipe required to complete the tasks, and an allowance of no more than 30mm wastage for each task is permissible. The pipe should be cut to length, bend dimensions marked out and machine bent. Any excess material should be removed prior to completion of the task.

The candidate on completion should take final measurements of the pipe and confirm that the task meets the dimensional tolerances specified by placing his/ her initials in the dimension details boxes in the chart on drawing CT-6B.

The candidate should complete the task successfully to the standards detailed in the practical task.

### **Task CT-6C**

The candidate is provided with drawing CT-6C, he/she should identify the length of pipe required to complete the tasks, the amount of pipe used to undertake each task should be determined by the candidate based on the machine type being used and it's ability to safely bend the tube i.e. minimum pipe length to safely clamp in the machine. The dimensions for 'Passover B' should be determined by the centre, recorded for the purposes of checking by the Internal/ External Verifier and the same assessment conditions (dimensional information) should be consistently applied to all candidate assessments. Any excess material should be removed prior to completion of the task.

The candidate on completion should take final measurements of the pipe and confirm that that the task meets the dimensional tolerances specified by placing his/ her initials in the dimension details boxes in the chart on drawing CT-6C.

The candidate should complete the task successfully to the standards detailed in the practical task.

### **Task CT-7**

This task may be combined with CT-4 & 5, providing that the pipe lengths produced met the standards detailed in tasks CT-4&5.

On completion of the jointing exercise the pipework should be capped at appropriate points. The pipework section should be hydraulically tested to a test pressure of 3 Bar for a 3 minute test period. All joints should be leak free. Confirmation that the joints are leak free should be recorded by placing a tick in the pressure test detail boxes in the chart on drawing CT-7.

The candidate should complete the task successfully to the standards detailed in the practical task.

### **Task CT-8**

The candidate is provided with drawing CT-8. The centre should determine a vertical height from a datum line for the tasks, the vertical height should be recorded by the centre for the purposes of checking by the Internal/External Verifier and the same assessment conditions (dimensional information) should be applied to all candidate assessments.

The candidate should mark out, drill and fix the pipework fixings.

The candidate on completion should take final measurements of the fixings and confirm that each task meets the dimensional tolerances specified by placing his/ her initials in the dimension details boxes in the chart on drawing CT-8.

The candidate should complete the task successfully to the standards detailed in the practical task.

### **Task CT-9**

The candidate is provided with drawing CT-9. The tasks may be combined with tasks CT-1, 2 & 3 provided the standards for those tasks were successfully met.

The position of pipework and appliances should be marked out and fixings made. The pipework should be fabricated and joints should be made to meet the task specification.

The candidate on completion should take final measurements of the key task dimensions and confirm that the dimensional tolerances have been met by placing his/ her initials in the standards detail boxes in the chart on drawing CT-9.

On completion of the exercise the pipework should be capped at appropriate points. The pipework sections should be hydraulically tested to a test pressure of 3 Bar for a 3 minute test period. All joints should be leak free. Confirmation that the joints are leak free should be recorded by placing the candidate initials in the appropriate box in the chart on drawing CT-9.

The candidate should complete the task successfully to the standards detailed in the practical task.

### **Plastic Pipework (PP)**

#### **Task PP-1**

The candidate is provided with drawing PP-1. The candidate should identify from the drawing the material/ fittings requirement and determine the 'x' dimensions of the fittings. The candidate should be able to determine the pipework requirements for the task and complete the chart on drawing PP-1.

Note: it may be necessary to use spigotted sockets to take measurements for the 110mm soil system element of the task.

The candidate should complete the task successfully to the standards detailed in the practical task.

## **Task PP-2**

The candidate is provided with drawing PP-2. The centre should determine dimensions for the task as indicated on the drawing, these dimensions should be recorded for the purposes of checking by the Internal/External Verifier and the same assessment conditions (dimensional information) should be consistently applied to all candidate assessments. He/she should measure and record the length of pipe required to economically complete the task. A fittings/fixings list should be produced for the task which should identify fitting/fixing type, manufacturer's catalogue and reference number.

The materials listing and pipe calculation detail should be provided on a separate sheet of paper (in the candidate's own writing together with his/her name and the date of assessment). The sheet should be inserted in the Practical Task Manual after the PP-2 recording sheet.

The candidate should mark out the position of pipework, appliances and fixings. The pipework should be cut, jointed and fixed to meet the requirements of the task specification.

The candidate on completion should take final measurements of the task and confirm that the work meets the task standards by placing his/ her initials in the boxes in the chart on drawing PP-2.

The candidate should complete the task successfully to the standards detailed in the practical task.

## **Task PP-3**

The candidate is provided with drawing PP-3. The assessor should ensure that safe access is provided to the work area and the candidate should confirm the safety of the access equipment with the assessor prior to the work taking place. The centre should determine dimensions for the task as indicated on the drawing, these dimensions should be recorded for the purposes of checking by the Internal/External Verifier and the same assessment conditions (dimensional information) should be consistently applied to all candidate assessments. The candidate should measure and record the length of pipe required to economically complete the task. A fittings/fixings list should be produced for the task which should identify fitting/fixing type, manufacturer's catalogue and reference number.

The materials listing and pipe calculation detail should be provided on a separate sheet of paper (in the candidate's own writing together with his/her name and the date of assessment). The sheet should be inserted in the Practical Task Manual after the PP-3 recording sheet.

The candidate should install brackets in the appropriate fixing positions, cut, joint and fix the gutter/rainwater pipe to the requirements of the task specification.

The candidate on completion should take final measurements of the task and confirm that the work meets the task standards by placing his/her initials in the boxes in the chart on drawing PP-3.

The candidate should check the flow of water from the gutter and confirm that the rainwater system is leak free.

The candidate should complete the task successfully to the standards detailed in the practical task.

#### **Task PP-4**

The candidate is provided with drawing PP-4, he/she should be able to select the appropriate fittings for the task and determine the 'x' dimensions of the fittings. Detail of the fitting 'x' dimensions should be recorded by the candidate in the chart in drawing PP-4. The candidate should then determine the pipework requirements for the task and complete the remainder of the chart on drawing PP-4.

The candidate should complete the task successfully to the standards detailed in the practical task.

#### **Air Testing (AT)**

##### **Task AT-1**

The candidate is required to carry out the air testing of a section of 110mm soil pipework provided by the assessor. The candidate should be able to select appropriate air test equipment and assemble the equipment as necessary. Test procedures should be carried out in line with British Standards:

- 38mm water gauge test pressure
- 3 minute test period

The candidate should complete the task successfully to the standards detailed in the practical task.

#### **Low Carbon Steel (LCS) (SP)**

##### **Task SP-1**

The candidate is provided with drawing SP-1 and is provided with appropriate radiators from which he/she can take the required task measurements. Alternatively a manufacturer's catalogue may be used to obtain radiator dimensions.

The candidate records the appropriate radiator details in the chart on Drawing SP-1.

The materials listing and pipe calculation detail should be provided on a separate sheet of paper (in the candidate's own writing together with his/her name and the date of assessment). The sheet should be inserted in the practical task manual after the SP-1 recording sheet.

The candidate should complete the task successfully to the standards detailed in the practical task.

##### **Task SP-2**

This task should be incorporated with task SP-1 & 3. The candidate should demonstrate his/ her ability to measure and mark out the required pipework and radiator dimensions.

The candidate should complete the task successfully to the standards detailed in the practical task.

### **Task SP-3**

The task should be incorporated with task SP-1 & 2. The candidate should demonstrate his/ her ability to select appropriate pipe fixings for the task from a range of pipe fixings and mark out the position of the pipe fixings and the fixing requirements of the radiators.

The candidate should complete the task successfully to the standards detailed in the practical task.

### **Task SP-4**

This task should be incorporated with task SP-5. The candidate should measure and record the length of pipe required to complete the task. A fitting list should be produced for the task which should identify fitting type, manufacturer's catalogue and reference number.

He/she should be able to select appropriate fittings for the task and determine the 'z' dimensions of the fittings. Detail of the fitting 'z' dimension should be recorded by the candidate in the chart on drawing SP-4. The candidate should then determine the pipework requirements for the task and complete the remainder of the chart on SP-4.

The materials listing and pipe calculation detail should be provided on a separate sheet of paper (in the candidate's own writing together with his/her name and the date of assessment). The sheet should be inserted in the practical task manual after the SP-4 recording sheet.

The candidate should complete the task successfully to the standards detailed in the practical task.

### **Task SP-5**

This task should be incorporated with task SP-4. The candidate should mark and cut the pipe to the required lengths using the pipe cutting methods identified.

The candidate should complete the task successfully to the standards detailed in the practical task.

### **Task SP-6A**

The candidate is provided with drawing SP-6A, he/she should identify the length of pipe required to complete the tasks, and an allowance of no more than 30mm wastage for each task is permissible. The pipe should be cut to length, bend dimensions marked out and machine bent. Any excess material should be removed prior to completion of the task.

The candidate on completion should take final measurements of the pipe and confirm that the task meets the dimensional tolerances specified by placing his/ her initials in the dimension details boxes in the chart on drawing SP-6A.

The candidate should complete the task successfully to the standards detailed in the practical task.

### **Task SP-6B**

The candidate is provided with drawing SP-6B, he/she should identify the length of pipe required to complete the tasks, and an allowance of no more than 30mm wastage for the task is permissible. The pipe should be cut to length, bend dimensions marked out and machine bent. Any excess material should be removed prior to completion of the task.

The candidate on completion should take final measurements of the pipe and confirm that the task meets the dimensional tolerances specified by placing his/ her initials in the dimension details boxes in the chart on drawing SP-6B.

The candidate should complete the task successfully to the standards detailed in the practical task.

### **Task SP-7**

This task may be combined with SP-4&5, providing that the pipe lengths produced met the standards detailed in tasks SP-4&5.

On completion of the jointing exercise the pipework should be capped at appropriate points. The pipework section should be hydraulically tested to a test pressure of 3 Bar for a 3 minute test period. All joints should be leak free. Confirmation that the joints are leak free should be recorded by placing his/ her initials in the pressure test detail boxes in the chart on drawing SP-7.

The candidate should complete the task successfully to the standards detailed in the practical task.

### **Task SP-8**

The candidate is provided with drawing SP-8. The tasks may be combined with tasks SP – 1, 2 & 3 provided the standards for those tasks were successfully met.

The position of pipework and appliances should be marked out and fixings made. The pipework should be fabricated and joints should be made to meet the task specification.

The candidate on completion should take final measurements of the key task dimensions and confirm that the dimensional tolerances have been met by placing his/ her initials in the standards detail boxes in the chart on drawing SP-8.

On completion of the exercise the pipework should be capped at appropriate points. The pipework sections should be hydraulically tested to a test pressure of 3 Bar for a 3 minute test period. All joints should be leak free. Confirmation that the joints are leak free should be recorded by placing the candidate initials in the appropriate box in the chart on drawing SP-8.

The candidate should complete the task successfully to the standards detailed in the practical task.

## **Sheet Lead Weathering (SW)**

### **Task SW-1**

The centre is required to prepare a range of sheet lead material samples, jointing processes and fixing materials.

The candidate should correctly identify the range of materials shown.

The candidate should complete the task successfully to the standards detailed in the practical task.

### **Task SW-2**

This task must be amalgamated with tasks SW-5 & SW-6.

The candidate identifies the correct code of sheet lead material required. He/ she then identifies the sizes of sheet lead materials required to complete the range of components, then marks and sets out the sheet lead for cutting.

The candidate should complete the task successfully to the standards detailed in the practical task.

### **Task SW-3**

This task must be amalgamated with tasks SW-5 & SW-6.

The candidate successfully cuts the sheet lead material to the dimensional tolerances laid down.

The candidate should complete the task successfully to the standards detailed in the practical task.

### **Task SW-4**

This task must be amalgamated with task SW-6.

The candidate fabricates a chimney front apron to the measurements of the chimney. Half of the apron bossed and half lead-welded.

The candidate should complete the task successfully to the standards detailed in the practical task.

### **Task SW-5**

This task must be amalgamated with task SW 2 & 3.

The candidate fabricates a lead slate to weather a 110 mm vent pipe penetration through a roof. The lead slate materials are jointed by lead welding. The lead slate is fabricated to suit the roof pitch.

On completion the lead slate is installed on a roof model, suggested that the roof penetration is amalgamated with model used for Task SW-6.

The candidate should complete the task successfully to the standards detailed in the practical task.

### **Task SW-6**

This task must be amalgamated with task SW 2, 3 & 4.

The candidate fabricates and installs the sheet lead components to the requirements of the drawing and standards laid down for the task.

**A minimum of a half chimney must be weathered i.e. half back gutter (lead-welded), half front apron (bossed) and flashings to one side of the chimney.**

Centres are required to provide a sheet lead model to which the components are loosely wedged (but not pointed). The model:

- Can be located at ground level
- Must effectively simulate a chimney penetration with –
  - the chimney materials built in brick – 450mm x 450mm minimum dimensions
  - there must be a minimum of 600mm tiled roof surface in all directions surrounding each individual chimney
  - the roof structure at a pitch of 30-45°
  - the roof structure must be real tile or slate with back board, tilting fillet and roofing felt should be provided
  - the roof structure and chimney penetration of suitable size to effectively simulate a real roof type situation
- Brickwork and roof covering must be maintained by the centre in a commercially acceptable condition so that the chimney effectively simulates real work conditions

The candidate should complete the task successfully to the standards detailed in the practical task.

Where two candidates are working on the same chimney, the centre must establish procedures to ensure that candidates individually carry out their own work.

### **Task SW-7**

The candidate successfully identifies the maintenance requirement of a sheet lead installation as:

- Missing roof covering materials
- Loose sheet lead components

The candidate carries out the maintenance activities to the standards laid down in the assessment task.

The candidate should complete the task successfully to the standards detailed in the practical task.

## Airing Cupboard Installation (AC)

The candidate installs and soundness tests a hot water storage cylinder and a cold water storage cistern to existing pipe supplies.

The centre must provide assessment facilities as follows:

- A simulated airing cupboard must be provided (the airing cupboard may/ may not be situated in an installation bay. The wall surfaces of the cupboard must be either of render and finish plaster to brickwork, dry lined to brickwork or timber stud partition with finish plaster to plasterboard. The wall surfaces must be kept in a tidy condition with drill holes etc. filled from assessment to assessment
- The airing cupboard must be refurbished when the wall surface materials are not of a commercially acceptable standard
- The cupboard must be a minimum height of 2.3 m, the location for the cistern may be either on a pre-fitted platform or in a simulated roof space above
- The cupboard must be no greater than 900 mm wide and 900 mm deep
- The cylinder, cistern and components used must be in good condition and to a commercially acceptable standard. The cylinder must be of minimum dimension 900mm x 450mm pre-lagged to Building regulations part L1 requirements. The CWSC must be minimum 100 litres storage capacity
- Existing cold water, hot water and overflow pipework should be provided at low level in the cupboard (existing pipework should be no more than 200 mm above floor level)
- Cold water to the cupboard must be supplied such that work being carried out adjacent to the cupboard by other candidates does not affect the water supply to the cupboard
- Connections may be made to the existing pipework with capillary fittings
- All hot and cold water fittings (excluding incoming connection) must be capillary soldered fittings and all the pipework must be newly installed
- Overflow pipe in plastic (need not discharge to outside)
- The hot water pipework must be connected to a working appliance in order to soundness test the installation
- The cylinder must be fitted (by the candidate) with an immersion heater blank or immersion heater – electrical connection not required
- All tests and check to be carried out to meet Water Regulation requirements

The candidate should complete the task successfully to the standards detailed in the practical task.

Note:

1. A pre-drilled cistern may be used for the task. The candidate is however required to demonstrate measuring, marking out and drilling connections to cisterns using alternative materials.
2. **As an alternative to this task being undertaken in an approved 6129 scheme assessment centre, it is acceptable for this task to be undertaken in the workplace using evidence from the Plumbing 6089 NVQ Scheme provided that the 6089 scheme recording documentation is used and the conditions laid down in the 6129 Scheme Handbook (page 33) are met in full for this task activity.**

## **Bathroom Installation (BI)**

The candidate installs and soundness tests the sanitary ware installed in a bathroom situation together with combi boiler jig, panel radiator and associated mains pipework.

- WC to be close coupled
- Pedestal wash basin (flexible hoses not permitted for pipework connections)
- Full size bath and panels
- Manufacturer produced combi-jig (cross connecting pipework required for testing purposes)
- Panel radiator

All the sanitaryware must be in good condition and to a commercially acceptable standard and all of matching colour.

The equipment must be installed in an installation bay of sufficient size to accommodate the above components within its dimensions. The bay must be full room height (minimum 2.0 metres) and must include a full ceiling and all necessary lighting. The centre must produce a scale plan of the installation bay(s) which must include the location of the pipework system to which the candidate must work

The bay must contain dedicated cold water and drainage/ soil pipework to enable work to be carried out in the bay without the supply being affected by work carried out adjacent to that bay. Soil pipework can be pre-fitted where boxed-in.

The wall surfaces of the bathroom must be either of render and finish plaster to brickwork, dry lined to brickwork or timber stud partition with finish plaster to plasterboard. The wall surfaces must be kept in a tidy condition with drill holes etc. filled from assessment to assessment. The wall surface must be emulsion painted between assessments. The candidate should not make excessive marks on the wall surface. The bathroom wall surfaces must be refurbished when the wall surface materials are not of a commercially acceptable standard.

All pipework must be to a commercially acceptable standard and 'boxed-in' to meet usual customer requirements. All the pipework must be newly installed.

Concealed pipework must be 'plastics pressure pipe'.

Surface pipework and final connections to components must be in copper; all bends to be fabricated by machine and joints to be made using new capillary solder fittings

The central heating pipework connections to the combi boiler jig must be in 22mm diameter tube and must terminate across the opposite side of the room, to effectively simulate main central heating pipe runs. The centre may produce simulated combi boiler jigs, where simulations are used these should be of realistic dimensions

The floor surface may be either suspended timber or solid concrete (with solid concrete all the pipework must be accommodated in boxing to fully simulate actual site conditions – see drawing)

The candidate should complete the task successfully to the standards detailed in the practical task.

Two model drawings are shown overleaf to identify typical bathroom layouts – suspended timber and solid floor.

Note:

**As an alternative to this task being undertaken in an approved 6129 scheme assessment centre, it is acceptable for this task to be undertaken in the workplace using evidence from the Plumbing 6089 NVQ Scheme provided that the 6089 scheme recording documentation is used and the conditions laid down in the 6129 Scheme Handbook (page 32) are met in full for this task activity.**

# Model Bathroom Installation Drawing – Suspended Timber Floor

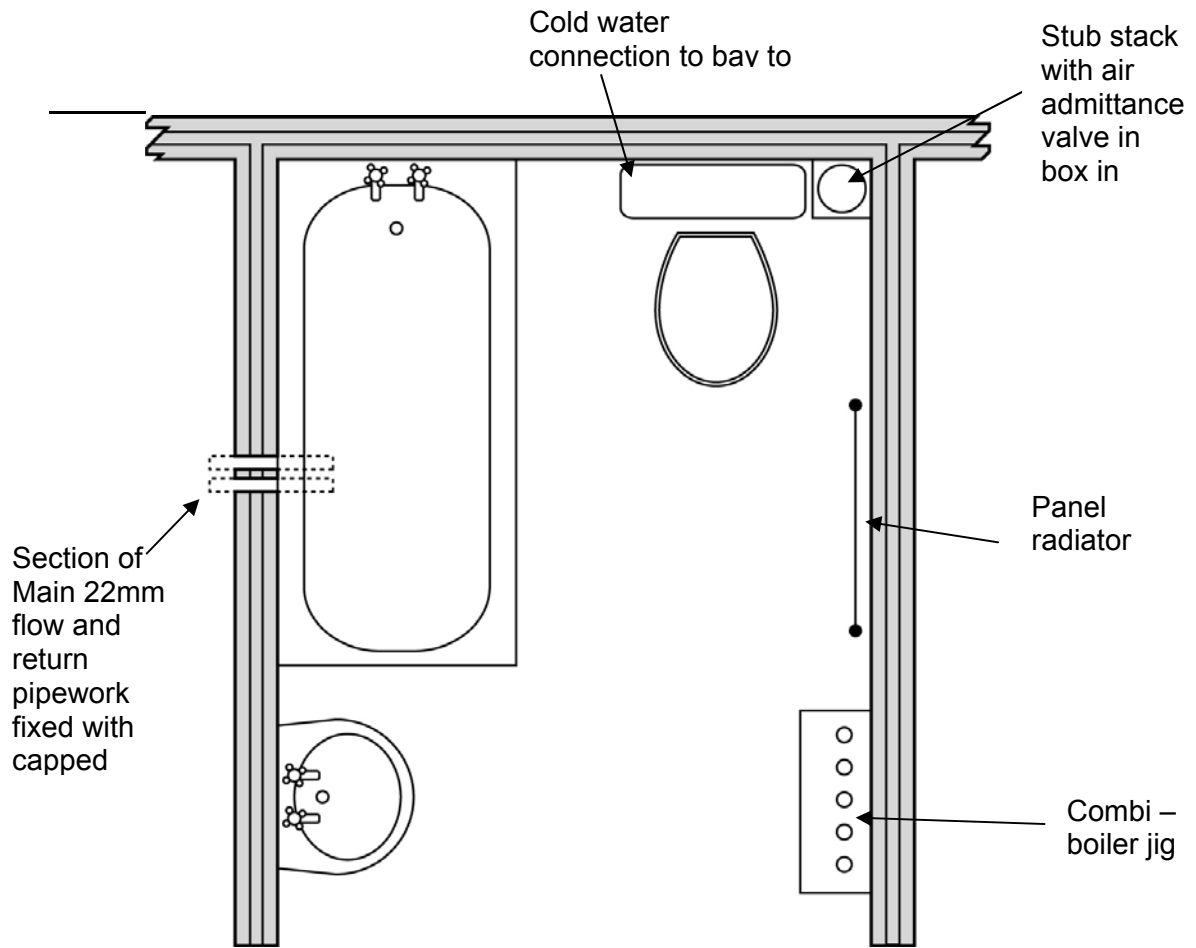

# Model Bathroom Installation Drawing – Solid Floor

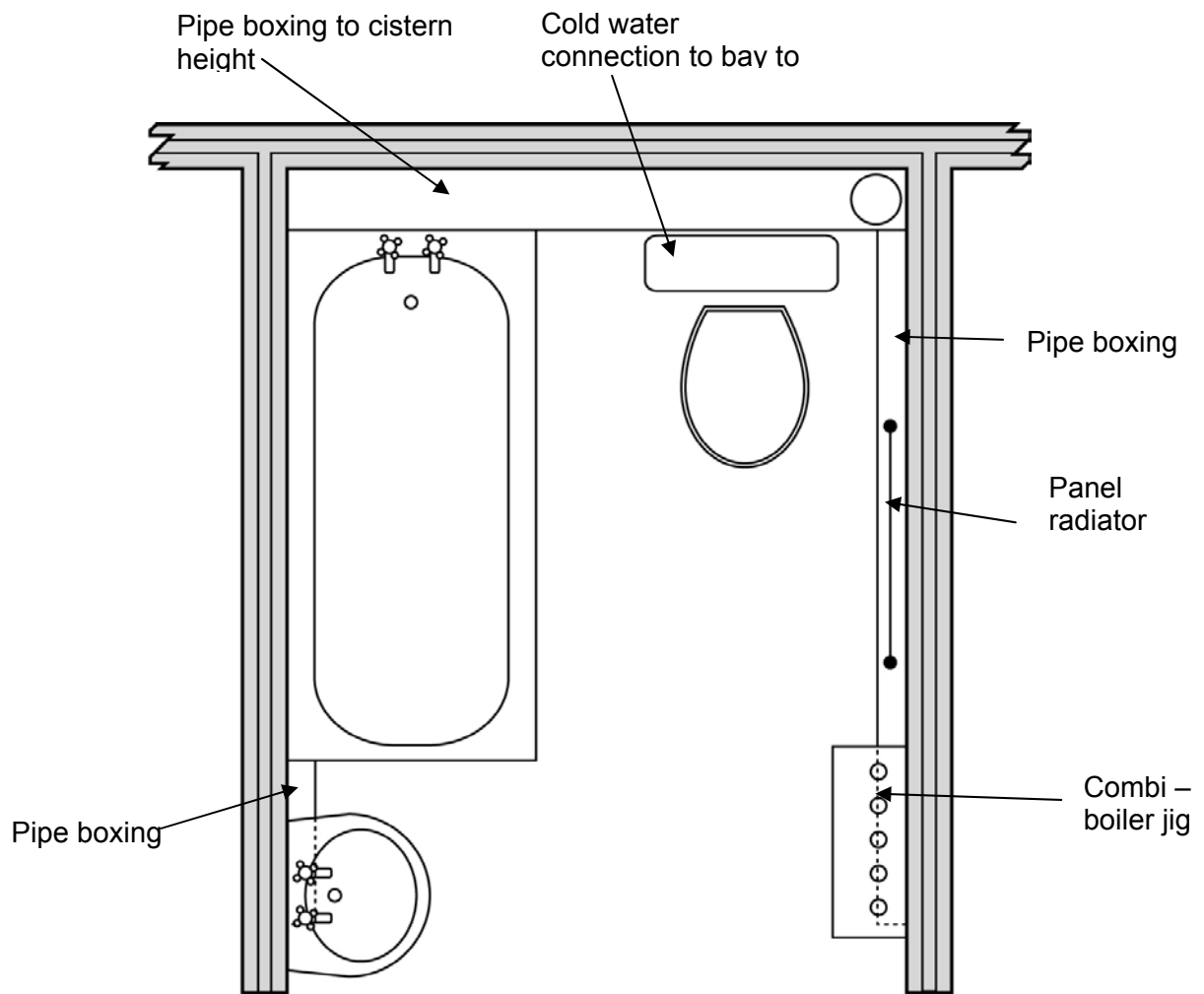

### **Task DC-1**

The task may be amalgamated with the bathroom installation exercise BI-1-5.

The candidate safely decommissions a hot and cold water supply system including the removal of system components.

The candidate should complete the task successfully to the standards detailed in the practical task.

### **Task DC-2**

The task may be amalgamated with the bathroom installation exercise BI-1-5.

The candidate safely decommissions an above ground sanitation system including the removal of system components.

The candidate should complete the task successfully to the standards detailed in the practical task.

### **Task RM-1**

The candidate is required to carry out routine maintenance of a pillar tap and a float operated valve. The routine maintenance activity should take place on a 'live system', the centre should create defects to the part(s) of the items to be maintained.

The candidate should identify that the key elements of the task have been completed by placing his/ her initials in the standards attained boxes in the chart for RM-1.

The candidate should complete the task successfully to the standards detailed in the practical task.

### **Task RM-2**

The candidate is required to carry out routine maintenance of a shower mixer valve. The routine maintenance activity can take place on a component which is not connected to the system; the centre should create defects to the part(s) of the items to be maintained.

The candidate should complete the task successfully to the standards detailed in the practical task.

### **Task RM-3**

The candidate is required to carry out replacement of a radiator valve. The routine maintenance activity should take place on a 'live system'; the centre should create defects to the part(s) of the items to be maintained.

The candidate should complete the task successfully to the standards detailed in the practical task.

#### **Task RM-4**

The candidate is required to carry out replacement of a WC siphon. The routine maintenance activity should take place on a 'live system'; the centre should create defects to the part(s) of the items to be maintained.

The candidate should complete the task successfully to the standards detailed in the practical task.

#### **Task EA-1**

This task must be assessed with tasks – SP-8, SW-6, AC tasks & BI tasks.

The task assesses the ability of the candidate to economically use materials and resources.

The candidate should complete the task successfully to the standards detailed in the practical task.

#### **Task TB-1**

This task should be carried out with another suitable task previously identified at Level 2.

The candidate is required to apply temporary earth continuity bonding in order to remove a section of pipework and maintain the earth continuity of a metallic pipework system.

The candidate should complete the task successfully to the standards detailed in the practical task.

#### 4. Summary of Level 3 Task Activities and Timings - Gas Route

<b>Gas Central Heating &amp; Unvented Installation &amp; Commissioning</b>		
<b>REF.</b>	<b>TASK COMPETENCE</b>	<b>TIME</b>
GCHUV-1	Unvented system installation	28 hours
GCHUV-2	Gas boiler installation	
GCHUV-3	Control component and feed & vent apparatus installation	
GCHUV-4	Commissioning - hot & cold water	
GCHUV-5	Commissioning – central heating	
<b>Gas Appliance Installation &amp; Commissioning</b>		
<b>REF.</b>	<b>TASK COMPETENCE</b>	<b>TIME</b>
GAI-1	Gas space heater installation	2 hours
GAI-2	Gas cooker installation	2 hours
<b>Unvented Systems</b>		
<b>REF.</b>	<b>TASK COMPETENCE</b>	<b>TIME</b>
UV-1	Unvented system – service procedure	1 hour
UV-2	Unvented system – fault diagnostics	1 hour
UV-3	Unvented system - decommissioning	90 mins
<b>Gas Appliance – Service procedure</b>		
<b>REF.</b>	<b>TASK COMPETENCE</b>	<b>TIME</b>
GASM -1	Gas boiler – service procedure	1 hour
GASM-2	Gas water heater – service procedure	1 hour
GASM-3	Gas space heater – service procedure	1 hour
GASM-4	Gas cooker – service procedure	1 hour
<b>Gas Appliance – Fault Diagnostics</b>		
<b>REF.</b>	<b>TASK COMPETENCE</b>	<b>TIME</b>
GAFD-1	Gas boiler – fault diagnostics	1 hour
GAFD-2	Gas water heater – fault diagnostics	1 hour
GAFD-3	Gas space heater – fault diagnostics	1 hour
GAFD-4	Gas cooker – fault diagnostics	1 hour
CHFD-1	Central heating – fault diagnostics	1 hour
<b>Gas Appliance – Decommissioning</b>		
<b>REF.</b>	<b>TASK COMPETENCE</b>	<b>TIME</b>
GAD-1	Gas boiler – decommissioning	90 mins
GAD-2	Gas water heater – decommissioning	90 mins
GAD-3	Gas space heater – decommissioning	90 mins
GAD-4	Gas cooker – decommissioning	90 mins
<b>Commissioning</b>		
<b>REF.</b>	<b>TASK COMPETENCE</b>	<b>TIME</b>
COM-1	Commissioning – above ground sanitation system	45 mins
COM-2	Commissioning – boosted shower	45 mins
COM-3	Commissioning – macerator type WC	30 mins

## 5. Application of Level 3 Practical Tasks – Gas Route

### Gas Central Heating & Unvented Installation & Commissioning (GCHUV)

The candidate installs and commissions a fully pumped central heating system comprising:

- Gas boiler (already mounted with flue connected) main flow & return pipework to be connected
- Unvented hot water storage cylinder - to be connected to new primary pipework, existing hot & cold water supplies
- Fully pumped control system to be installed in airing cupboard – connected to existing main flow & return pipework to radiator system and electrical wiring system – note: wiring centre, programmer and room thermostat may be left permanently fixed from candidate activity to candidate activity. Full hard wiring of systems required (Smartfit type of connections not permissible).
- Method of feed & vent to system – may be either via feed & expansion cistern (platform left permanently in position), sealed system configuration or system boiler

The centre must provide assessment facilities as follows:

- A simulated airing cupboard must be provided (the airing cupboard may/ may not be situated in an installation bay). A boiler must however be provided adjacent to the airing cupboard to permit main flow & return pipework to be connected from boiler to control system in airing cupboard. The wall surfaces of the cupboard must be either of render and finish plaster to brickwork, dry lined to brickwork or timber stud partition with finish plaster to plasterboard. The wall surfaces must be kept in a tidy condition with drill holes etc. filled from assessment to assessment
- The airing cupboard must be refurbished when the wall surface materials are not of a commercially acceptable standard
- The cupboard must be a minimum height of 2.3 m, the location for the cistern (where fitted) may be either on a pre-fitted platform or in a simulated roof space above
- The cupboard must be no greater than 900 mm wide and 900 mm deep
- The components used must be in good condition and to a commercially acceptable standard and of a commercially acceptable size
- Existing cold water, hot water, main central heating flow & return pipework and unvented discharge pipework must be provided at low level in the cupboard (it is permissible to connect to this pipework using compression fittings)
- Cold water to the cupboard must be supplied such that work being carried out adjacent to the cupboard by other candidates does not affect the water supply to the cupboard
- All pipework must be in new copper with solder ring capillary fittings and all pipework newly fabricated
- Discharge pipework need not discharge to outside
- The hot water pipework must be connected to a working appliance in order to soundness test the installation
- The central heating mains pipework must be connected to a minimum of two radiators to permit full commissioning of the installation together with system balancing

- The immersion heater to the unvented cylinder must be connected to adjacent double pole switch by the candidate
- A 13 amp socket outlet must be provided in a suitable position, in or adjacent to the airing cupboard to provide the electrical supply to the system which must be fully wired by the candidate. The socket outlet must be protected by an RCD
- All tests and check to be carried out to meet Water Regulation requirements

A model drawing for the installation is shown below.

### Model Central Heating Installation

(Open Vented system shown)

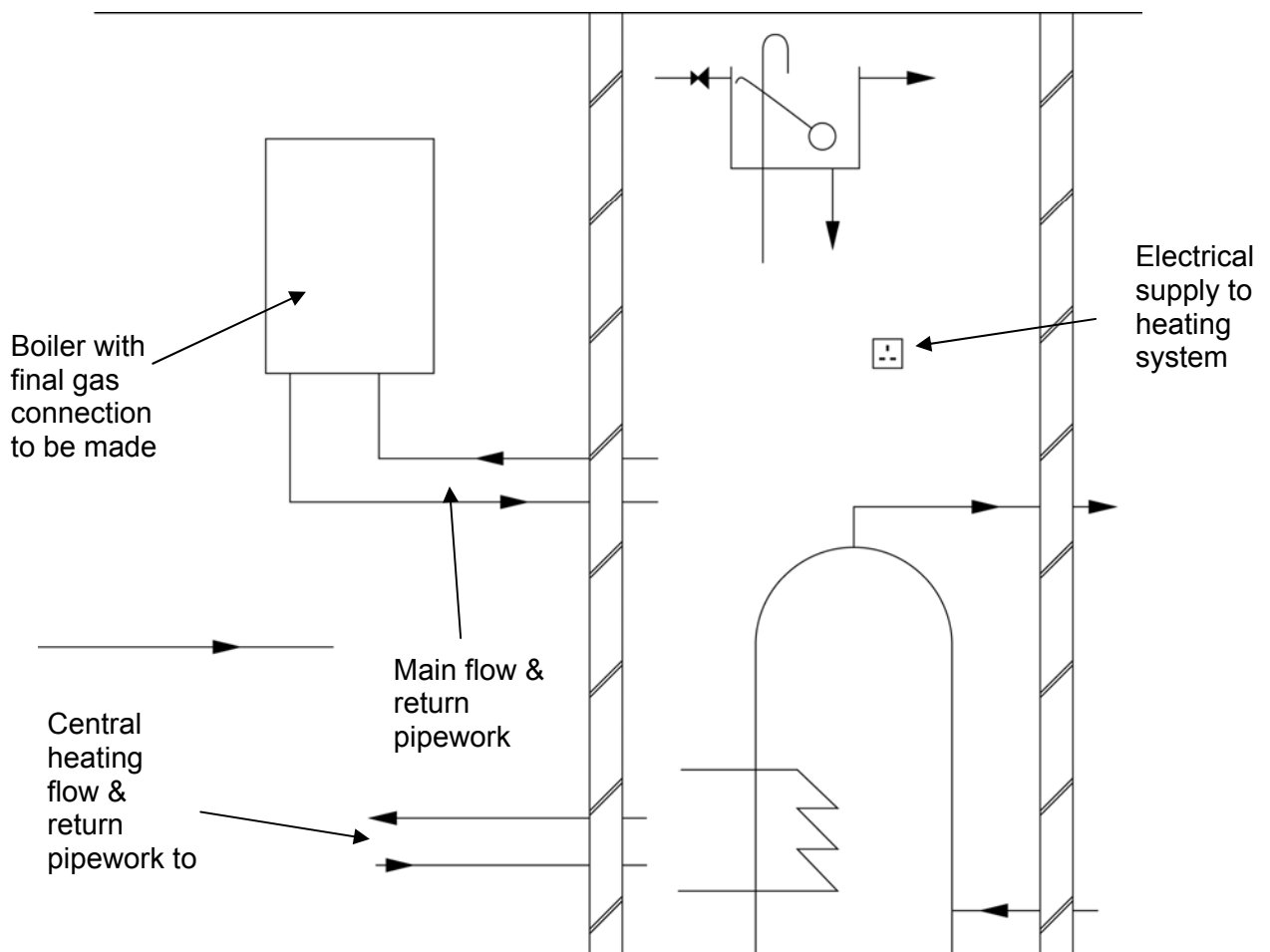

## Gas Appliance Installation & Commissioning Activities

A model drawing below shows detail of a bay laid out to contain gas appliances for the assessment exercises – the appliances for these tasks may or may not be contained in installation bays.

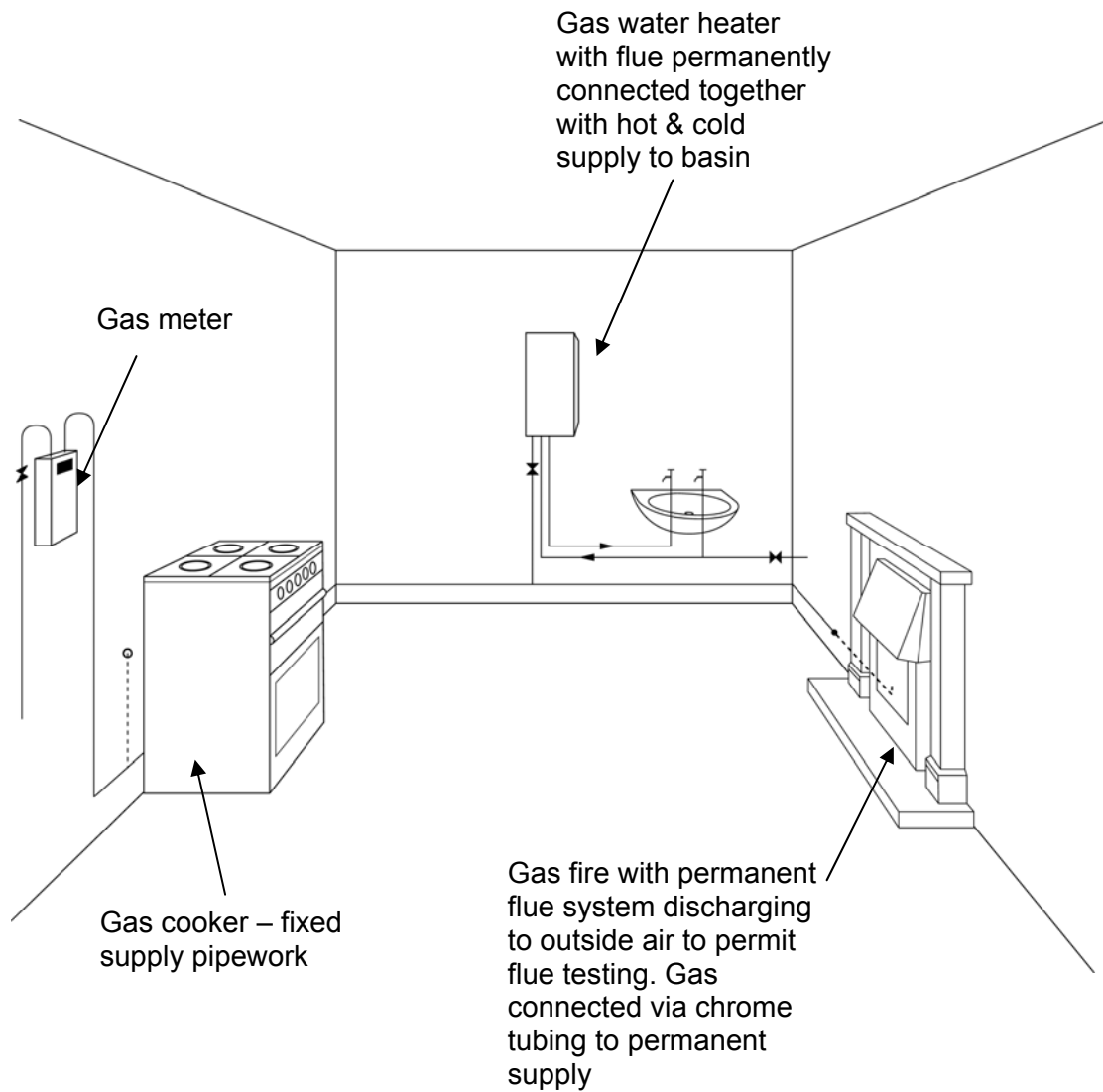

## **Gas Appliance Installation (GAI)**

### **Task GAI-1**

The candidate installs and commissions a radiant convector gas fire to an existing fireplace opening. Gas supply connected from restrictor elbow via chrome tubing.

The fireplace must be served by a fully working flue system.

The candidate should complete the task successfully to the standards detailed in the practical task.

### **Task GAI-2**

The candidate installs and commissions a gas cooker. The cooker must be a free-standing model with drop down lid safety cut off device. The installation must include a minimum of 0.5 metres of gas pipework and all appropriate fittings.

The candidate should complete the task successfully to the standards detailed in the practical task.

## **Unvented Hot Water (UV)**

### **Task UV-1**

The candidate demonstrates the correct service procedure on an unvented hot water storage system. The system used may be that installed in GCHUV-1.

The candidate should complete the task successfully to the standards detailed in the practical task.

### **Task UV-2**

The candidate demonstrates competences in diagnosing and rectifying faults in unvented hot water systems. The centre must place 2 component faults on a system which the candidate has not worked on prior to the activity. At least one of the faults must be on either the temperature relief valve, expansion valve or pressure reducing valve, requiring its replacement.

The fault must be correctly diagnosed, the system safely decommissioned, the fault rectified and the system commissioned and left in working order.

The candidate should complete the task successfully to the standards detailed in the practical task.

### **Task UV-3**

The candidate safely decommissions an unvented hot water storage system. This can be the same system as installed in GCHUV-1.

The candidate should complete the task successfully to the standards detailed in the practical task.

## **Gas Appliance Service & Maintenance Tasks (GASM)**

The candidate demonstrates the correct service procedure on the following 'live' gas appliances –

- Gas boiler
- Gas water heater
- Gas space heater
- Gas cooker

The gas boiler, space heater and cooker may be the same as installed in tasks GCHUV-1, GAI-1&2.

The candidate should complete the task successfully to the standards detailed in the practical task.

## **Gas Appliance Fault Diagnostics**

### **Task GAFD-1**

The candidate demonstrates competences in diagnosing faults on gas boilers. The centre must place 2 component faults on a boiler which the candidate has not worked on prior to the activity. One of the faults must prevent the boiler from completing its ignition sequence.

The candidate must identify a ventilation fault that may be associated with the installation of the appliance if it were installed in a cupboard – the centre must use its own pre-prepared materials to simulate this activity.

The candidate is not required to rectify the faults for this activity.

The candidate should complete the task successfully to the standards detailed in the practical task.

### **Task GAFD-2**

The candidate demonstrates competences in diagnosing faults on gas water heaters. The centre must place 2 component faults on a water heater which the candidate has not worked on prior to the activity. One of the faults must be on the water flow to gas linkage device preventing the hot water supply.

The candidate must identify a flue fault that may be associated with the incorrect termination of a room sealed water heater flue terminal – the centre must use its own pre-prepared materials to simulate this activity.

The candidate is not required to rectify the faults for this activity.

The candidate should complete the task successfully to the standards detailed in the practical task.

### **Task GAFD-3**

The candidate demonstrates competences in diagnosing faults on gas space heaters. The centre must place 2 component faults on a space heater which the candidate has not worked on prior to the activity. One of the faults must be a gas leak on the appliance itself.

The candidate must identify a flue fault that may be associated with the incorrect routing and use of incorrect materials in an open flue system – the centre must use its own pre-prepared materials to simulate this activity.

The candidate is not required to rectify the faults for this activity.

The candidate should complete the task successfully to the standards detailed in the practical task.

#### **Task GAFD-4**

The candidate demonstrates competences in diagnosing faults on gas cookers. The centre must place 2 component faults on a cooker which the candidate has not worked on prior to the activity. One of the faults must be a defect on the oven thermostat.

The candidate is not required to rectify the faults for this activity.

The candidate should complete the task successfully to the standards detailed in the practical task.

### **Central heating Fault Diagnostics**

#### **Task CHFD-1**

The candidate demonstrates competences in diagnosing faults on central heating systems. The centre must place 2 component faults on a system which the candidate has not worked on prior to the activity. One of the faults must be an electrical defect on a control component.

In addition the candidate must also identify a defect on the feed & vent circuit serving a system which can either be a contravention of the Water Regulations or would constitute a hazard to personal safety.

The candidate is not required to rectify the faults for this activity.

The candidate should complete the task successfully to the standards detailed in the practical task.

### **Gas Appliance Decommissioning Tasks (GAD)**

The candidate demonstrates the correct decommissioning procedure on the following 'live' gas appliances –

- Gas boiler
- Gas water heater
- Gas space heater
- Gas cooker

The gas boiler, space heater and cooker may be the same as worked on in previous tasks.

The candidate should complete the task successfully to the standards detailed in the practical task.

## **Commissioning (COM)**

### **Task COM-1**

The candidate carries out performance testing of an above ground sanitation system comprising of a minimum of 3 sanitaryware appliances connected to a common stack.

The candidate confirms that the system meets the performance specification.

The candidate should complete the task successfully to the standards detailed in the practical task.

### **Task COM-2**

The candidate commissions and performance tests a boosted shower installation that is permanently installed in the centre, the booster pump must be supplied via a cold water storage cistern and feeds to a thermostatic shower mixer valve. The installation must therefore be served by an uninterrupted water supply. The candidate confirms that the installation meets the performance specification.

The candidate should complete the task successfully to the standards detailed in the practical task.

### **Task COM-3**

The candidate commissions and performance tests a macerator type WC that is permanently installed in the centre that is fully functional. The candidate confirms that the installation meets the performance specification.

The candidate should complete the task successfully to the standards detailed in the practical task.

6. Application of Level 3 Practical Tasks – Oil Route (Northern Ireland Centres Only)

Summary of Oil Task Activities and Timings

<b>Oil Heating Installation &amp; Commissioning</b>		
<b>REF.</b>	<b>TASK COMPETENCE</b>	<b>TIME</b>
OILH-1	Oil fired boiler installation (one pipe system)	2 from the 3 must be completed @ 2 hours each
OILH-2	Oil fired boiler installation (one pipe system with de-aerator)	
OILH-3	Oil fired boiler installation (two pipe system)	
OILH-4	Commissioning oil fired boiler	With UVCH task
<b>Oil Appliance – Service Procedure</b>		
<b>REF.</b>	<b>TASK COMPETENCE</b>	<b>TIME</b>
OILH-5	Oil fired boiler – service procedure	1 hour
<b>Oil Appliance – Fault Diagnostics</b>		
<b>REF.</b>	<b>TASK COMPETENCE</b>	<b>TIME</b>
OILH-6	Oil fired boiler – fault diagnostics	1 hour
<b>Oil Appliance – Decommissioning</b>		
<b>REF.</b>	<b>TASK COMPETENCE</b>	<b>TIME</b>
OILH-7	Oil fired boiler – decommissioning	90 minutes
<b>Unvented System and Central Heating Installation &amp; Commissioning</b>		
<b>REF.</b>	<b>TASK COMPETENCE</b>	<b>TIME</b>
UVCH-1	Unvented system installation	28 hours
UVCH-2	Control component and feed & vent apparatus installation	
UVCH-3	Commissioning - hot & cold water	
UVCH-4	Commissioning central heating	
<b>Central Heating – Fault Diagnostics</b>		
<b>REF.</b>	<b>TASK COMPETENCE</b>	<b>TIME</b>
CHFD-1	Central heating – fault diagnostics	1 hour
<b>Unvented Systems</b>		
<b>REF.</b>	<b>TASK COMPETENCE</b>	<b>TIME</b>
UV-1	Unvented system – service procedure	1 hour
UV-2	Unvented system – fault diagnostics	1 hour
UV-3	Unvented system - decommissioning	90 minutes
<b>Commissioning</b>		
<b>REF.</b>	<b>TASK COMPETENCE</b>	<b>TIME</b>
COM-1	Commissioning – above ground sanitation system	45 minutes
COM-2	Commissioning – boosted shower	45 minutes
COM-3	Commissioning – macerator type WC	30 minutes

## **7. Application of Level 3 Practical Tasks – Oil Route (Northern Ireland Centres Only)**

### **Oil Heating System Installation & Commissioning (OIL-H 1 ,2 ,3 & 4)**

The candidate installs an oil fired boiler (including all oil supply pipework and associated components) fed by two from the following list of fuel supply systems)

- One pipe oil supply system
- One pipe oil supply system with de-aerator
- Two pipe oil supply system

(Centres must supply facilities for the installation of all 3 types of fuel supply pipeline systems).

The boiler installation **MUST** be amalgamated with the UVCH range of assessments. The flue system may be pre-connected to the boiler, the remaining connections including fuel supply, central heating primaries and electrical supply must be made by the candidate.

For each installation the candidate must complete installation and commissioning of:

- All supply pipework from external oil supply tank to oil fired boiler
- Safety valves and devices appropriate to the system being installed (correctly positioned)
- Oil filters

The centre must provide assessment facilities as follows –

- An oil supply tank located in a position external of the bay, but suitable for the system that is to be installed in the bay (the tanks used can be smaller than would be found on site, to save room in the training centres).
- The components to be used must be in good condition and to a commercially acceptable standard and of a commercially acceptable size
- All pipework must be in new copper (Table Y) with manipulative (type B) compression fittings all pipework newly fabricated
- Discharge pipework need not discharge to outside
- A 13 amp socket outlet must be provided in a suitable position, adjacent to the boiler to provide the electrical supply to the system which must be fully wired by the candidate. The socket outlet must be protected by an RCD
- All tests and checks to be carried out to meet safety requirements

The candidate must also commission the above boiler installation including full heating testing and performance testing of the boiler (OILH 4).

A model drawing for each system installation is shown below.

Oil tank above burner

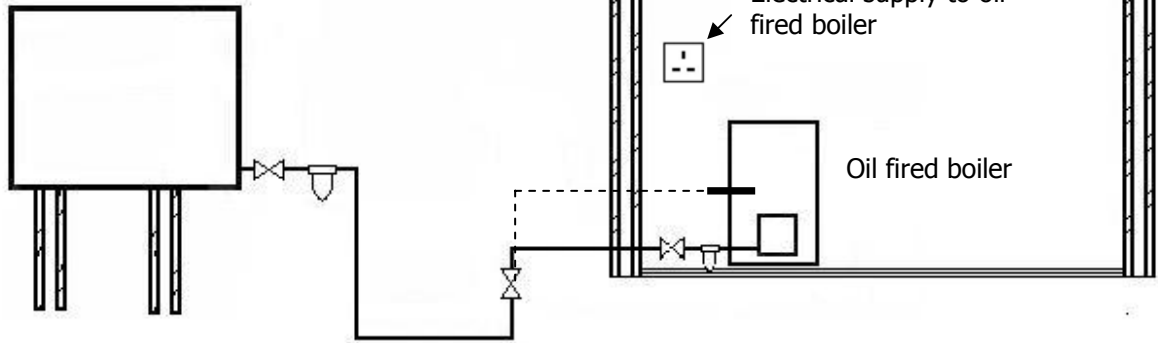

**One pipe oil supply system**

Oil tank below or level with burner

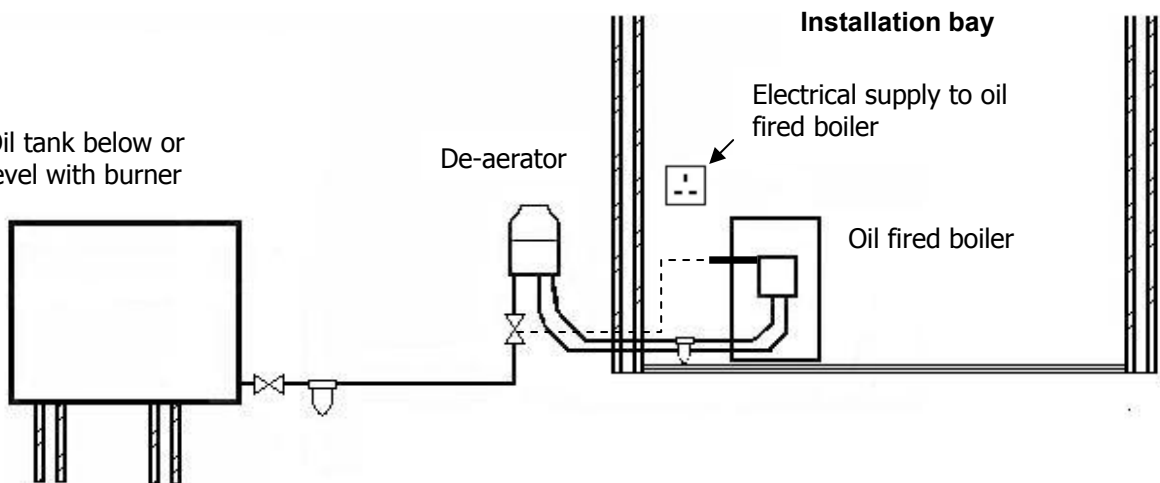

**One pipe oil supply system with de-aerator**

Oil tank below burner

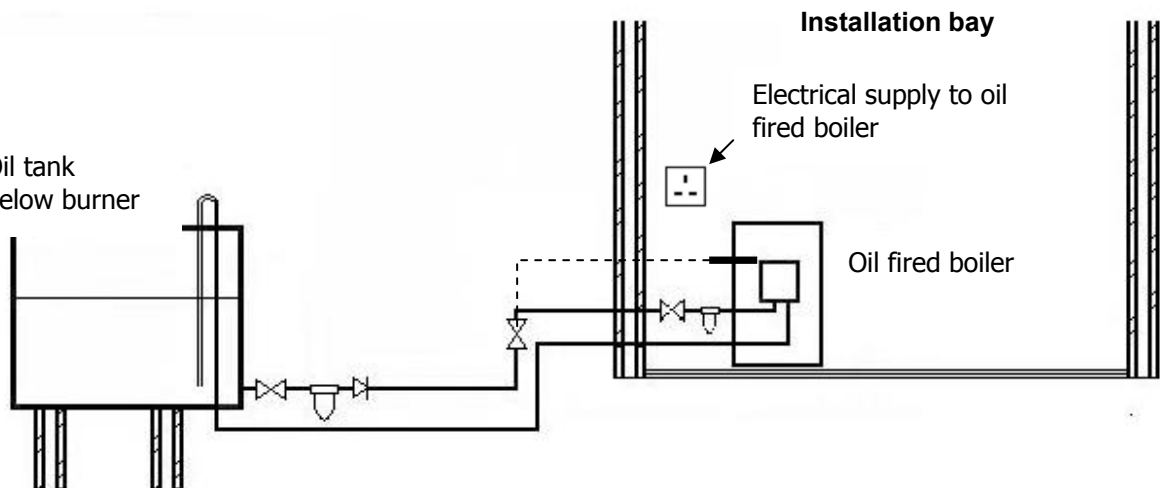

**Two pipe oil supply system**

## **Oil Appliance Service & Maintenance**

### **Task OILH-5**

The candidate demonstrates the correct service procedure on the following 'live' oil appliance:

- Oil boiler

The oil boiler may be the same as installed in tasks OILH -1, 2, 3.

The candidate should complete the task successfully to the standards detailed in the practical task.

## **Oil Appliance Fault Diagnostics**

### **Task OILH-6**

The candidate demonstrates competences in diagnosing faults on oil boilers. The centre must place 2 component faults on a boiler which the candidate has not worked on prior to the activity. One of the faults must prevent the boiler from completing its ignition sequence.

The candidate must identify a ventilation fault that may be associated with the installation of the appliance if it were installed in a cupboard – the centre must use its own pre-prepared materials to simulate this activity.

The candidate is not required to rectify the faults for this activity.

The candidate should complete the task successfully to the standards detailed in the practical task.

## **Oil Appliance Decommissioning**

### **Task OILH-7**

The candidate demonstrates the correct decommissioning procedure on the following 'live' oil appliances –

- Oil boiler

The oil boiler may be the same worked on in previous tasks.

The candidate should complete the task successfully to the standards detailed in the practical task.

## **Unvented System and Central Heating Installation & Commissioning (UVCH1, 2, 3 and 4)**

This should take place together with the OIL H 1, 2, 3 & 4 tasks.

The candidate installs and commissions a fully pumped central heating system (UVCH 1, 2, 3 and 4) comprising –

- Boiler (already mounted with flue connected – boiler can be one installed during OILH 1, 2 or 3) main flow & return pipework to be connected
- Unvented hot water storage cylinder - to be connected to new primary pipework, existing hot & cold water supplies
- Fully pumped control system to be installed in airing cupboard – connected to existing main flow & return pipework to radiator system and electrical wiring system – note: wiring centre, programmer and room thermostat may be left permanently fixed from candidate activity to candidate activity. Full hard wiring of systems required (Smartfit type of connections not permissible).
- Method of feed & vent to system – may be either via feed & expansion cistern (platform left permanently in position), sealed system configuration or system boiler

The centre must provide assessment facilities as follows –

- A simulated airing cupboard must be provided (the airing cupboard may/ may not be situated in an installation bay). A boiler must however be provided adjacent to the airing cupboard to permit main flow & return pipework to be connected from boiler to control system in airing cupboard. The wall surfaces of the cupboard must be either of render and finish plaster to brickwork, dry lined to brickwork or timber stud partition with finish plaster to plasterboard. The wall surfaces must be kept in a tidy condition with drill holes etc. filled from assessment to assessment
- The airing cupboard must be refurbished when the wall surface materials are not of a commercially acceptable standard
- The cupboard must be a minimum height of 2.3 m, the location for the cistern (where fitted) may be either on a pre-fitted platform or in a simulated roof space above
- The cupboard must be no greater than 900 mm wide and 900 mm deep
- The components used must be in good condition and to a commercially acceptable standard and of a commercially acceptable size
- Existing cold water, hot water, main central heating flow & return pipework and unvented discharge pipework must be provided at low level in the cupboard (it is permissible to connect to this pipework using compression fittings)
- Cold water to the cupboard must be supplied such that work being carried out adjacent to the cupboard by other candidates does not affect the water supply to the cupboard
- All pipework (other than oil supply pipework) must be in new copper with solder ring capillary fittings and all pipework newly fabricated
- Discharge pipework need not discharge to outside
- The hot water pipework must be connected to a working appliance in order to soundness test the installation

- The central heating mains pipework must be connected to a minimum of two radiators to permit full commissioning of the installation together with system balancing
- The immersion heater to the unvented cylinder must be connected to adjacent double pole switch by the candidate
- A 13 amp socket outlet must be provided in a suitable position, in or adjacent to the airing cupboard to provide the electrical supply to the system which must be fully wired by the candidate. The socket outlet must be protected by an RCD
- All tests and check to be carried out to meet Water Regulation requirements

A model drawing for the installation is shown below.

### **Model Central Heating Installation**

(Open Vented system shown)

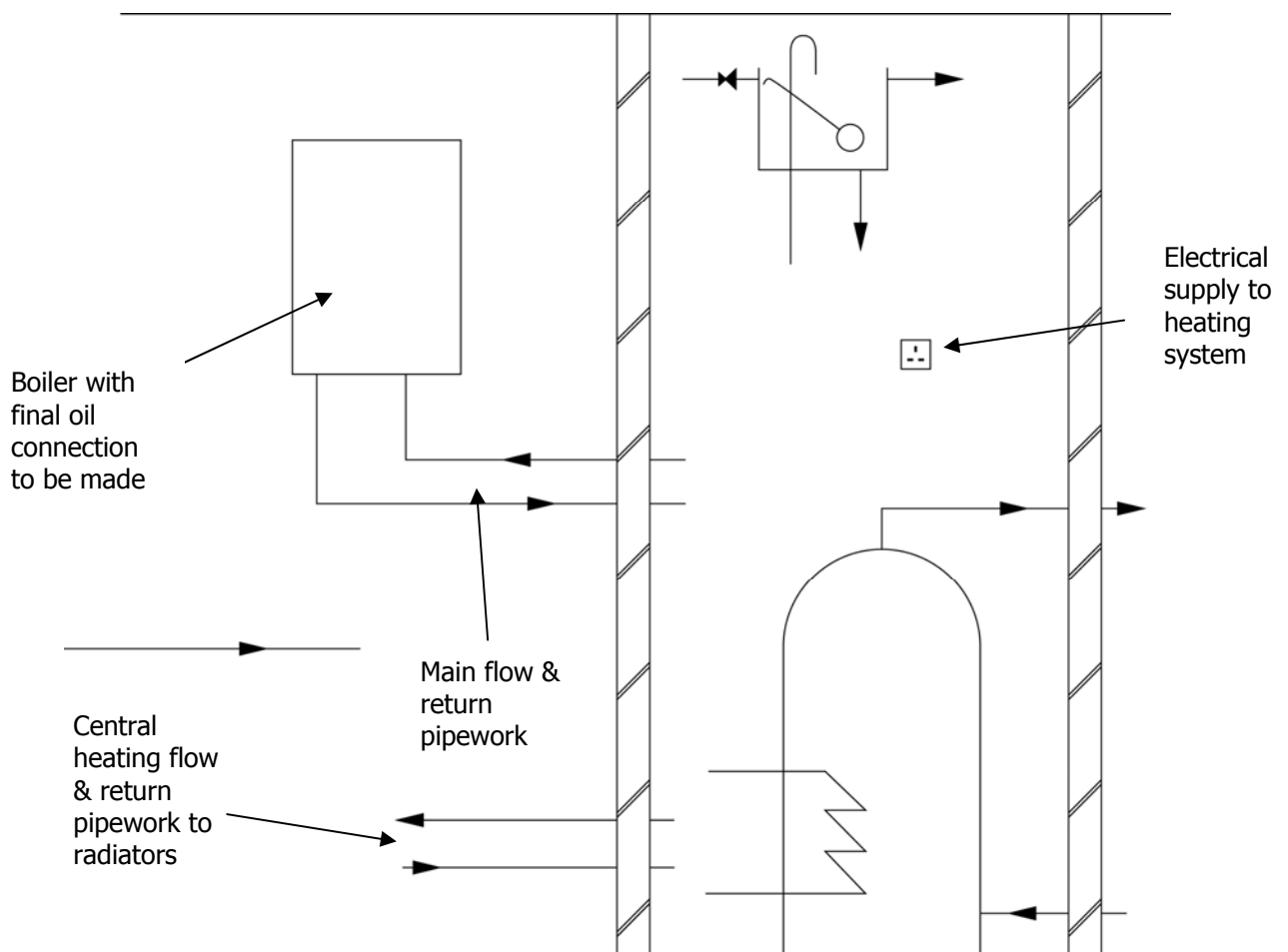

## **Central Heating Fault Diagnostics**

### **Task CHFD-1**

The candidate demonstrates competences in diagnosing faults on central heating systems. The centre must place 2 component faults on a system which the candidate has not worked on prior to the activity. One of the faults must be an electrical defect on a control component.

In addition the candidate must also identify a defect on the feed & vent circuit serving a system which can either be a contravention of the Water Regulations or would constitute a hazard to personal safety.

The candidate is not required to rectify the faults for this activity.

The candidate should complete the task successfully to the standards detailed in the practical task.

## **Unvented Hot Water (UV)**

### **Task UV-1**

The candidate demonstrates the correct service procedure on an unvented hot water storage system. The system used may be that installed in UVCVH-1 to 4.

The candidate should complete the task successfully to the standards detailed in the practical task.

### **Task UV-2**

The candidate demonstrates competences in diagnosing and rectifying faults in unvented hot water systems. The centre must place 2 component faults on a system which the candidate has not worked on prior to the activity. At least one of the faults must be on either the temperature relief valve, expansion valve or pressure reducing valve, requiring its replacement.

The fault must be correctly diagnosed, the system safely decommissioned, the fault rectified and the system commissioned and left in working order.

The candidate should complete the task successfully to the standards detailed in the practical task.

### **Task UV-3**

The candidate safely decommissions an unvented hot water storage system. This can be the same system as used in UVCH 1 to 4.

The candidate should complete the task successfully to the standards detailed in the practical task.

## **Commissioning (COM)**

### **Task COM-1**

The candidate carries out performance testing of an above ground sanitation system comprising of a minimum of 3 sanitaryware appliances connected to a common stack.

The candidate confirms that the system meets the performance specification.

The candidate should complete the task successfully to the standards detailed in the practical task.

### **Task COM-2**

The candidate commissions and performance tests a boosted shower installation that is permanently installed in the centre, the booster pump must be supplied via a cold water storage cistern and feeds to a thermostatic shower mixer valve. The installation must therefore be served by an uninterrupted water supply. The candidate confirms that the installation meets the performance specification.

The candidate should complete the task successfully to the standards detailed in the practical task.

### **Task COM-3**

The candidate commissions and performance tests a macerator type WC that is permanently installed in the centre that is fully functional. The candidate confirms that the installation meets the performance specification.

The candidate should complete the task successfully to the standards detailed in the practical task.