

The exam in brief

The aim of these qualifications is to enable the candidate to develop the necessary technical knowledge and understanding about the inspection and testing of new work (2394-01) and periodic inspection of existing electrical installations (2395-01) and the completion of appropriate documentation.

For each qualification, candidates are required to complete the following assessments:

- a multiple choice assessment
- a written assessment
- a practical assessment.

Unit 301 – Multiple choice examination

This examination covers areas of knowledge and understanding which are common to both initial verification and periodic inspection. This assessment is the same assessment for both qualifications and learners need only achieve the test once.

The examination comprises 40 questions and is 1 hour 20 minutes long. It is a 'closed book' examination, which means that you are not allowed to take any notes or reference books into the exam with you.

	Topic/outcome	No of questions	%
1	Understand the requirements for completing the safe isolation of electrical circuits and installations	7	18
2	Understand the requirements for inspecting and testing electrical installations	2	5
3	Understand the requirements for safe testing of electrical installations	11	27
4	Understand the requirements for testing circuits which are not energised	7	18
5	Understand the requirements for testing energised installations	13	32
	Total	40	100

Unit 302 – Written Examination

The examination papers for both qualifications (2394 and 2395) have the same format. They each have 6 structured questions and are 1 hour 30 minutes long. Each question is worth 15 marks.

Unit 303 – Practical assessment

Each qualification has an associated practical assessment element that must be completed to obtain the 2394 and 2395 certificates. Full details can be obtained from your centre.

Notes

Guidance on sitting the e-volve multiple choice examination

This section provides some useful information about the e-volve multiple choice examination for both qualifications (Unit 301). It considers:

- the format of the exam
- the structure of the questions
- effective methods of answering questions.

Format of the exam

The examination is presented online and is arranged so that each question and the choice of answers are viewed separately, so only one question is viewed on the screen at any time.

The structure of the questions

The questions are presented as a question stem, which may provide information and pose the actual question together with a choice of four possible answers, only one of which is correct.

Effective methods of answering questions

In order to have the best chance of success it is essential to read the question carefully and make sure you understand what is being asked. The answers provided will include one correct answer and understanding the question is key to selecting the right response.

Based on their experience candidates sometimes believe that the answer they want to give is not included in the choices. In such instances the best approach is to consider the options given and select the one which is most appropriate for the question being asked.

One of the key features of the system is the ability to flag a question where you are unsure of the answer. This is registered by the system and a flag indicator is placed next to the question. This allows you to identify and return to flagged questions at any time during the exam.

Notes

One helpful approach is to work through the exam answering those questions to which the answers are readily apparent and flagging those which require more thought. It may be a good idea to guess these answers at this stage just in case you run out of time and are unable to return to all the questions you have flagged. When reaching the end of the questions you can then return to your flagged questions and use the remaining time to answer these questions. This helps to take some of the time related pressure away as the remaining time can be shared across just the flagged questions. Spending a long time over one question early in the examination puts the candidate under time pressure for the rest of the examination, so try to avoid this by restricting the amount of time spent on one question. As a guide, spend no more than four minutes on any one question, but remember you need to average two minutes per question overall, so you can only spend this additional time on a few questions.

Do not leave any questions unanswered as these will not gain any marks. Where the answer is not apparent and further thought does not help the next option is to eliminate those answers which cannot be correct. This will help reduce the number of right answer options. One way to do this is to look at each answer in turn. Ask yourself “is this possibly right or is it definitely wrong?” You will need to use the information contained in the question to help with this. The wrong answers you can then dismiss. Now have another look at the answers that you feel are possibly right and make your final decision.

General guidance on sitting the written examinations 2394 and 2395

This section provides some useful information about the written examination for both qualifications (Unit 302) that you may find helpful. It considers:

- the format of the exam
- the structure of the exam
- how to interpret the questions and understand what is expected
- effective methods of answering questions.

It also identifies areas of the exam that are often not answered well and some of the most common errors that candidates make.

Format of the exam

The layout of each paper consists of a question, or part question, followed by a space for the candidate to enter their answer. It is important that the

answer is entered within the space provided and within the margins. The space provided for the answer is generous so that you have sufficient space to change your answer if you so wish. It is not an indication of how much you need to write. There is a total of ninety marks available for each of these papers. You are allowed 1 hour and 30 minutes to complete the examination and you are expected to answer all the questions. These examinations are “closed book”, which means that you are not allowed to take any notes or reference books into the exam with you.

Notes

Structure of the exam

Each paper is divided into two sections, Section A and Section B.

Section A of each paper has three questions which are often divided into a number of parts (a, b, c, and i, ii, iii) and so on), with each part of the question relating to a different learning outcome. The number of marks available for each part of the question is shown on the paper and this can be used to indicate how long to spend on your answer.

Section B also has three questions, but these relate to the scenario contained within a “source” document. These questions may also be divided into parts but often relate to a single learning outcome. Candidates are expected to display an in-depth knowledge of the particular subject. Typical examples include describing a test procedure or evaluating test results.

Interpreting questions and understanding what is expected in the written examination

There are two key points that need to be considered when reading the question:

Consider the number of marks available for the question or part question

This provides a valuable indication of the depth of the answer required. For example, a question which carries one mark will require a much simpler answer than one for which fifteen marks are available. Also the space provided for your answer gives an indication as to the amount you are expected to write or draw, but remember that the space is often generous.

Read carefully and answer what the question actually asks

Often a question is answered incorrectly because of a failure to understand what is being asked and what is required. It is an easy trap to fall into under

Notes

exam conditions where you are under pressure. The danger here is that you may answer a question to which you know the answer, but which is not the question you have been asked in the paper. Remember, the questions are set to establish your level of understanding in specific areas, so the correct response is important if the marks are to be obtained. Take a little longer to read the question carefully to ensure you are quite clear about what is required.

Wording of questions

The wording of a question, coupled with the number of marks available, gives valuable clues as to what is expected. The words used in the question provide the first clue. If you look out for the following words and phrases and understand what they mean, you should be able to provide an appropriate answer.

State: This means the answer is expected to be a short statement, not a long or rambling paragraph. The response to this type of question may even be just a single word or group of words which may not need to be a complete sentence.

List: This means you should produce a simple list of items or actions. The answer should be similar to that produced for the 'state' question. However, on this occasion the items would be expected to follow a sequence and form a list, as would be expected for a shopping trip.

Explain briefly: This requires a brief explanation; usually no more than one or two sentences. It does not require paragraphs of explanation and the word 'briefly' is used to indicate this requirement.

Explain with the aid of a diagram: This means exactly what it says. The answer should comprise both a diagram and an explanation. The examiner is trying to help you achieve maximum marks by asking for both an explanation and a diagram because this method of providing information is likely to be the most efficient.

Show all calculations: Again the examiner is trying to help you score as many marks as possible. Where a calculation is required and the only thing offered by the candidate is the numerical answer, then if it is wrong, the candidate would score no marks. If the candidate includes each step of the calculation then marks will be awarded for each correct step. It is always in your best interest to show all stages of the process. Where relevant

remember to show the applicable units which apply to your answer e.g. V, Ω , kA etc.

Notes

With the aid of a fully labelled diagram: This indicates that a diagram needs to be provided with the component parts clearly labelled. The marks for these questions are divided between the diagram and the labelling.

To obtain the maximum marks for the question both the labelling and the diagram must be completed.

Describe: These questions often relate to test procedures and you are required to demonstrate your knowledge of the test process. Look at the number of marks available to give you an indication of how much detail you need to go into.

Describe, in detail: This indicates that a more detailed answer is required and again the number of marks available for the question gives an indication of the depth of the answer required.

A series of short bullet pointed statements is a very effective method of providing an answer, but remember that all necessary information must be included.

Direct measurement: This indicates that a test is required and the results are not to be established by using a calculation. For example, where you are asked to describe the direct measurement of earth fault loop impedance, then a description of the test procedure is required. Describing an $R_1 + R_2$ test and then stating how to determine the value by calculation using $Z_s = Z_e + (R_1 + R_2)$ will result in no marks being awarded for the answer.

Terminology

It is important to answer questions using the correct terminology, which is the same as that used in Guidance Note 3 and BS 7671. Always use correct titles and terminology. Brand names should **not** be used to describe items of equipment, test instruments and the like. For example, the instrument used to test for continuity is a low resistance ohmmeter. It should not be referred to using a manufacturer's name (eg Megger) or referred to as a continuity tester. This is because the precise performance requirements given in BS 7671 and IET Guidance Note 3 must be met. Some continuity testers and instruments that provide continuity features may not meet these requirements.

Notes

Multifunction test instruments are commonly used for testing electrical installations. You need to be aware of the individual functions and ranges of these instruments. This includes such functions as insulation resistance, continuity, earth fault loop impedance and prospective fault current measurement. The appropriate measurement scale for a particular test must be clearly stated. Also be careful to use the correct units and symbols to describe test instrument readings ($m\Omega$, Ω , $M\Omega$, A, kA, ms etc).

The use of the correct terminology for the component parts of an electrical system is also important. The application of the terms used in BS 7671 is necessary as this leaves no doubt as to the part being described. Typical terms include earthing conductor, main protective bonding conductors and circuit protective conductors. Terms such as 'earth wires' or 'cross bonding' do not correctly identify components and the examiner is unable to award marks for such items.

Another common error is the use of incorrect titles for documents. If you refer to the 'Electricity at Work Act' instead of the 'Electricity at Work Regulations' or the 'Health and Safety at Work Regulations' instead of the 'Health and Safety at Work Act', this will result in no marks being awarded. This also applies to the title of documents which are completed during the inspection and testing process and handed to the client.

Common problem areas associated with Section B

Section B of each paper is related to a scenario which is given in the Source Document. The scenario gives details of an electrical installation, or part of an installation. It identifies what is to be carried out, and provides information that is to be used to answer the final three questions on the exam paper. This means that the answers to these questions should relate to the installation identified in the scenario.

The most common error made by candidates at this point in the paper is failing to read the scenario and apply the information given to these final three questions. For example, when the scenario clearly states a TN-C-S system is used and a question asks for a diagram of the earth fault loop path, producing a drawing of a TN-S system will result in no marks being awarded for that question.

It may be beneficial for you to highlight key pieces of information in the scenario. This will help you to concentrate on what you are reading and will

make referencing information easier when you are answering the questions. This technique may also be useful when reading individual questions.

Notes

You are expected to be able to describe the procedures for carrying out activities, including the inspection and testing of installations and circuits. These descriptions should follow the format given in IET Guidance Note 3.

Common errors when answering questions that relate to the scenario are:

- not obtaining permission for isolation or for testing to proceed.
- no isolation procedure mentioned when it is appropriate
- no instrument and lead check carried out
- incorrect procedures described, such as not being able to describe the three steps in IET Guidance Note 3 for ring final circuit continuity
- not describing the test process in the correct sequence
- failure to consider the safety aspects necessary for the testing process
- failure to reinstate the installation safely once testing is complete.

Confirmation of compliance

Some questions are included to establish your ability to confirm that measured test results meet the requirements of BS 7671. In order to do this you will be expected to show what steps are taken for this process and any calculations that may be involved. You will also be expected to identify appropriate action for any situations where the results do not meet the requirements. This will be different for initial verification (2394) compared with periodic inspection (2395).

A common area for error is the application of the 'rule of thumb' to the maximum tabulated values of earth fault loop impedance (these maximum values will be given in the scenario or question information) in order to compare these with the measured values. When candidates do not correctly apply the rule of thumb, it shows they are unable to correctly identify compliance with BS 7671 and therefore no marks are awarded.

Schedules of test results

The section B questions and/or the source document may include details of test values obtained or a Schedule of Test Results may be provided. Questions may then relate to confirming the compliance of the installation or circuits based upon the information given on these documents and other given details such as maximum tabulated Z_s values from BS 7671.

Putting your answers on paper

There are many ways in which questions can be answered and you will need to find the method that best suits you. Here are some hints to help you decide on a style.

It is important to remember when you are answering the questions that the examiners cannot:

- ask you further questions to establish your understanding – they can only award marks for the information you provide
- assume what you mean or know – they can only interpret the information they are given in your answers.

Due to the time constraints of the exam, do **not** waste time by copying out the question. The question you are answering is directly above the space where you are writing your answer, so the examiner can see the question when marking, just as you can see it while completing your answer.

The marking of your answers does not include any penalties or additional marks for spelling or grammar. However, the examiners will still need to be able to read your answers and your handwriting, so write as clearly as possible.

The completed scripts are scanned so they can be read and marked electronically and blue or black ink provides the clearest text and pencil should not be used for text. Providing the examiners can understand your response (and the answer is correct), then marks will be awarded.

The answers do not need to be in the form of an essay or long descriptive text. A simple bullet pointed, step-by-step approach to the answer provides you with an easy reference as to what you have included when you read back through the answer. It also allows you to insert any item you have missed and you can indicate the correct location to the examiner.

Using diagrams

Notes

When answering questions use the best method for you to be able to provide the information required. If the question does not specifically ask for a drawing, but a drawing is a helpful way for you to answer, then use a drawing. For example, if the question asks how a ring final circuit continuity test is carried out, then the first step is relatively easy to explain. When it comes to steps two and three, with the cross connection requirements, then using a drawing can save you a lot of time and writing.

Drawing a diagram like the one below for example is all that is required to explain the cross connection requirements for step three of the test.

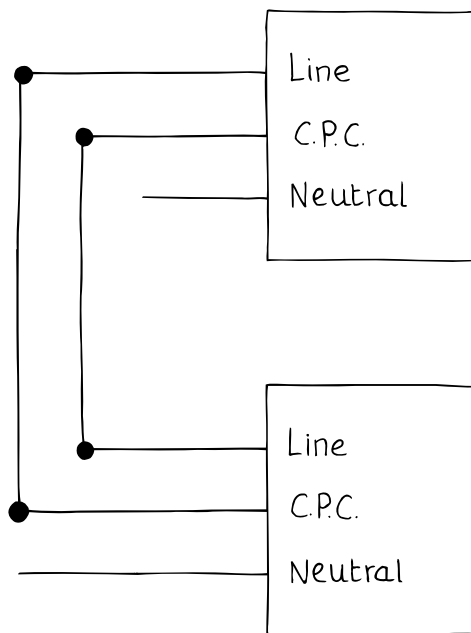

So, wherever it helps your explanation or saves a lot of writing, use a diagram or drawing to illustrate what you mean. Using coloured pens or pencils and adding labels may make the drawing clearer. It is not necessary to use a ruler to produce straight lines. You can save time if you neatly draw freehand. Make the drawings large enough to clearly show what you wish to show. Postage stamp size drawings are rarely helpful.

Notes

Tips from the examiners – e-volve multiple choice examination (2394-301 and 2395-301)

The following tips are intended to aid confident test performance. Some are general tips and would apply to most exams. Others are specific to the multiple choice online assessment procedure.

- ✓ If you rarely use a computer try to get some practice beforehand. You need to be able to use a mouse to move the cursor arrow around the screen as you will need to use the positioning of the cursor and the mouse buttons to select the correct answer.
- ✓ Remember, this is a closed book exam.
- ✓ Make the most of the course before you take the exam and be prepared to set time aside for revision before the exam.
- ✓ Allow enough time to get to the exam venue and try to allow yourself 30 minutes to settle in and be ready to log on.
- ✓ Listen carefully to the instructions given by the invigilator.
- ✓ Take the time to read each question carefully before you answer it. Do not rush – you should have plenty of time.
- ✓ You should attempt to answer every question because if a question is not answered it is awarded no mark. Using your knowledge to eliminate any obvious wrong answers and then making an educated guess from the remainder may help you select the correct answer
- ✓ Remember to bring your calculator (a scientific one is useful) and a pen. A sheet of blank paper will be provided by the centre to allow you to carry out any calculations which may be required.
- ✓ If you are having difficulty with a particular question use the flag facility and go onto the next question. You can come back to any flagged questions later.

Frequently asked questions – e-volve multiple choice examination (2394-301 and 2395-301)

Notes

When can I sit the paper?

The online examination can be taken at any time. Your centre agrees the time and date with City & Guilds and the centre will tell you when this is.

Can I use any reference books in the test?

No, the exam is closed book so you are not allowed to take any books or reference materials in with you.

How many different parts of the test are there?

The paper contains 40 questions which cover the sections of the scheme identified earlier.

Do I have a time limit for taking the exam?

You have one hour and twenty minutes to complete the test.

Do I need to be good at IT to take the online test?

No, the system is really easy to use and there is a practice session before you begin the test.

What happens if the computer crashes during the test?

This is unlikely to happen due to the system design. As the operating systems provided by centres vary from centre to centre you will need to discuss this with the particular centre where you are to take your examination.

Can people hack into the system and cheat?

There are many levels of security built into the system and each candidate receives a different question paper making cheating very difficult.

Can I change my answer?

Yes, you can change your answers easily at any time during the test up to the point where you end the exam. Using the flag facility for questions you are unsure of, will allow you to review these questions before ending the exam.

Is there only one correct answer either A, B, C or D for the multiple choice questions?

Yes.

Notes

What happens if I don't answer all the questions?

You should answer all the questions as any unanswered questions will not be awarded a mark. Use the flag system to review any questions you are unsure of.

What grades of pass are there?

Pass or Fail.

When can I re-sit the test if I fail?

Your centre will tell you when you can re-sit.

How long after the exam will I know the result?

Normally exam results are issued immediately after the examination.

How many times can I re-sit the exam?

Theoretically there is no limit to the number of times you can attempt the exam, but if you have failed the exam a number of times then you probably need additional help from your centre.

Tips from the examiners – Written examination (2394-302 and 2395-302)

- ✓ Remember, this is a closed book exam.
- ✓ Make the most of the course before you take the exam and be prepared to set time aside for revision before the exam.
- ✓ Allow enough time to get to the exam venue and try to allow yourself 30 minutes to settle in, complete your details on the question paper/answer book, and so on.
- ✓ Listen carefully to the instructions given by the invigilator.
- ✓ Take the time to read each question carefully before you answer it. Do not rush – you should have plenty of time.
- ✓ You should allocate approximately 15 minutes to each question.
- ✓ Attempt to answer every question.
- ✓ Remember to bring your calculator (a scientific one is useful) and pens and pencils with you.

-
- ✓ You may find coloured pencils and a highlighter beneficial, to highlight relevant parts of the “source document”, for instance.
 - ✓ Make sure that your answer sits within the space provided after each question.
 - ✓ There should be sufficient space for your answer, but you may not need to use all the space. If you have not got sufficient space you may continue an answer on an additional sheet. Make sure that you indicate the number of additional sheets that you use. There is a box on the front cover of the paper for this purpose. Any additional sheets should be attached to the back of the paper so make sure you identify your name, candidate number and the question number on each additional sheet used. Do not write your answer anywhere outside of the correct area. This includes any blank pages within the answer book.

Notes

Frequently asked questions – Written examination (2394-302 and 2395-302)

When can I sit the paper?

As this is a written examination, there are set exam dates. Your centre will tell you on what date you will be sitting the paper.

Can I use any reference books in the written test?

No, the exam is closed book so you are not allowed to take any books or reference materials in with you.

How many different parts of the written test are there?

Each paper is divided into two sections, Section A and Section B. There are three questions in each section. The three questions in Section A do not relate to any specific installation, while the three questions in Section B specifically relate to the scenario given in the source document.

Do I have a time limit for taking the written exam?

You have one hour and thirty minutes to complete the test.

What grades of pass are there?

Pass or Fail.

When can I re-sit the test if I fail?

At the next available examination date, following the receipt of your results, subject to centre agreement.

Notes**How long after the exam will I know the result?**

Normally exam results are issued after 45 working days from the date of the examination.

How many times can I re-sit the exam?

Theoretically there is no limit to the number of times you can attempt the exam, but if you have failed the exam a number of times then you probably need additional help from your centre.

Exam content – Level 3 Award in the Initial Verification and Certification of Electrical Installations (2394-01)

The aim of the course is to enable you to develop the necessary technical knowledge and understanding about the inspection, testing and certification of new work. The syllabus has eleven learning outcomes and these are assessed across the three assessment methods:

301 – an online multiple choice test which can be taken on demand using e-volve software. This will be arranged by your centre

302 – A six question written paper at fixed dates throughout the year. Your centre will tell you when these are available

303 – A practical assignment delivered and assessed by your centre.

The learning outcomes are shown below.

Outcome 1 – Understand the requirements for completing the safe isolation of electrical circuits and installations

You are required to be able to:

- 1.1** State the requirements of the Electricity at Work Regulations for the safe inspection of electrical systems and equipment
- 1.2** Specify the appropriate procedure for completing safe isolation
- 1.3** State the reasons for carrying out safe isolation

-
- 1.4 State the implications of carrying out safe isolation
 - 1.5 State the implications of not carrying out safe isolation
 - 1.6 Identify the Health and Safety requirements which apply when inspecting, testing and commissioning electrical installations and circuits
-

Notes

Outcome 2 – Understand the requirements for initial verification of electrical installations

You are required to be able to:

- 2.1 State the purpose of the Initial Verification of electrical installations
 - 2.2 State the requirements of the initial verification
 - 2.3 Identify the relevant documents associated with the inspection, testing and commissioning of an electrical installation
 - 2.4 Specify the information that is required by the inspector to conduct the initial verification of an electrical installation
-

Outcome 3 – Understand the requirements for completing the inspection of electrical installations prior to their being placed into service

You are required to be able to:

- 3.1 Select appropriate items to be checked during the inspection process
- 3.2 Identify human senses appropriate for initial verification
- 3.3 State how the senses can be used during the inspection process
- 3.4 Specify the requirements for the inspection of electrical installations
- 3.5 Specify the requirements for the inspection to include:
 - Special installations and locations as identified in Part 7 of BS 7671
 - IP Classification of equipment

Outcome 4 – Understand the requirements for the safe testing and commissioning of electrical installations

You are required to be able to:

- 4.1** State the tests to be carried out on an electrical installation in accordance with the BS 7671 and IET Guidance Note 3
- 4.2** Identify the appropriate instrument for each test to be carried out in terms of:
 - The instrument is fit for purpose
 - Identifying the correct scale or setting
- 4.3** Specify the requirements for the safe use of instruments to be used for testing and commissioning, to include:
 - Checks required to prove that test instruments are safe and functioning correctly
 - The requirements for test leads and probes must comply with HSE Guidance GS38
 - The need for instruments to be regularly checked and calibrated
- 4.4** Explain why it is necessary for test results to comply with standard values
- 4.5** State the actions to be taken in the event of unsatisfactory results being obtained
- 4.6** Explain why testing is carried out in the sequence specified in BS 7671 and IET Guidance Note 3

Outcome 5 – Understand the requirements for testing before circuits are energised

You are required to be able to:

- 5.1** State why it is necessary to verify continuity to include:
 - Protective bonding conductors
 - Circuit protective conductors
 - Ring final circuit conductors
- 5.2** State the methods for verifying continuity to include:
 - Protective conductors
 - Ring final circuit conductors

-
- 5.3** Explain factors that effect conductor resistance values
- 5.4** Specify the procedures for completing insulation resistance testing
- 5.5** State the effects on insulation resistance values that the following can have
- cables connected in parallel
 - variations in cable length
- 5.6** Explain why it is necessary to verify polarity
- 5.7** State the procedures for verifying polarity
-

Notes

Outcome 6 – Understand the requirements for testing energised installations

You are required to be able to:

- 6.1** State the procedures for confirming polarity of the incoming supply
- 6.2** Specify the methods for measuring earth electrode resistance to include:
- installations forming part of a TT system
 - generators and transformers
- 6.3** Describe common earth fault loop paths
- 6.4** State the methods for verifying protection by automatic disconnection of supply
- 6.5** Identify the requirements for the measurement of prospective fault current
- 6.6** Specify the methods for determining prospective fault current
- 6.7** Verify the suitability of protective devices for prospective fault currents
- 6.8** Specify the methods for testing the correct operation of residual current devices
- 6.9** State the reasons for verifying phase sequence
- 6.10** State the methods used to verify phase sequence
- 6.11** State the need for functional testing
- 6.12** Identify items which require functional testing
- 6.13** State the appropriate procedures for dealing with clients during the commissioning and certification process.

Notes

Outcome 7 – Understand the requirements for the completion of electrical installation certificates and associated documentation

You are required to be able to:

- 7.1** Explain the purpose of certification and associated documentation
- 7.2** State the information that must be contained on initial verification documentation
- 7.3** Describe the certification process for a completed installation
- 7.4** Identify the responsibilities of different relevant personnel in relation to the completion of the certification process
- 7.5** Explain the requirements for the recording and retention of completed initial verification documentation in accordance with the BS 7671

Outcome 8 – Be able to confirm safety of system and equipment prior to completion of inspection, testing and commissioning

You are required to be able to:

- 8.1** Carry out safe isolation procedures in accordance with regulatory requirements
- 8.2** Comply with the health and safety requirements of themselves and others within the work location during the initial verifications process
- 8.3** Check the safety of electrical systems prior to the commencement of inspection, testing and commissioning

Outcome 9 – Be able to carry out inspection of electrical installations prior to them being placed into service

You are required to be able to:

- 9.1** Identify a safe system of work appropriate to the work activity
- 9.2** Carry out an initial inspection of an electrical installation in accordance with the requirements of BS 7671 and IET Guidance Note 3
- 9.3** Complete a Schedule of Inspections in accordance with BS 7671 and IET Guidance Note 3

Outcome 10 – Be able to test electrical installations prior to them being placed into service

Notes

You are required to be able to:

- 10.1** Select the test instruments and their accessories for tests to include:
- continuity
 - insulation resistance
 - polarity
 - earth electrode resistance
 - earth fault loop impedance
 - prospective fault current
 - RCD operation
 - phase sequence
 - functional testing
- 10.2** Carry out tests in accordance with BS 7671 and IET Guidance Note 3 to include:
- continuity including
 - main protective bonding conductors
 - circuit protective conductors
 - ring final circuits
 - insulation resistance
 - polarity
 - external earth fault loop impedance (Z_e)
 - system earth fault loop impedance (Z_s)
 - prospective fault current
 - RCD operation including additional protection
 - phase sequence
 - functional testing
- 10.3** Confirm compliance by verifying test results
- 10.4** Complete appropriate documentation in accordance with the BS 7671 and IET Guidance Note 3 including:
- Electrical Installation Certificate
 - Schedule of Inspections
 - Schedule of Test results

Notes

Outcome 11 – Be able to commission electrotechnical systems and equipment

You are required to be able to:

- 11.1** Clarify the commissioning procedures with relevant persons
 - 11.2** Carry out the commissioning of circuits, accessories and equipment to confirm functionality
-

Exam content – Level 3 Award in the Periodic Inspection, Testing and Certification of Electrical Installations (2395-01)

The aim of the course is to enable you to develop the necessary technical knowledge and understanding about the inspection and testing of existing electrical installations and producing a report on the condition of the installation. The syllabus has thirteen learning outcomes and these are assessed across the three assessment methods:

- 301** – An online multiple choice test which can be taken on demand using e-volve software. This will be arranged by your centre.
- 302** – A six question written paper at fixed dates throughout the year. Your centre will tell you when these are available.
- 303** – A practical assignment delivered and assessed by your centre.

The learning outcomes are shown below.

Outcome 1 – Understand the requirements for completing the safe isolation of electrical circuits and installations

You are required to be able to:

- 1.1** State the requirements of the Electricity at Work Regulations for the safe inspection of electrical systems and equipment
- 1.2** Specify the appropriate procedure for completing safe isolation
- 1.3** State the reasons for carrying out safe isolation
- 1.4** State the implications of carrying out safe isolation
- 1.5** State the implications of not carrying out safe isolation
- 1.6** Identify the Health and Safety requirements which apply when inspecting, testing and commissioning electrical installations and circuits