

T Level Technical Qualification in Building Services Engineering for Construction

Refrigeration Engineering (8710-38)
(358) – **Candidate pack**

Practical Assignment 2020 – Sample

Version and date	Change detail	Section
1.1 May 2021	Task 4 updates to what needs to be submitted for marking	Task specific guidance

SAMPLE

Contents

1. Assessment	4
2. Candidate Guidance	6
3. Assignment Brief	8
4. Tasks	11
Task 1 – Design	11
Task 2 – Planning the installation	12
Task 3 – Install and Commission	13
Task 4 – Service and maintenance	14

SAMPLE

1. Assessment

This assessment is for the refrigeration engineering occupational specialism component of the Technical Qualification. This pack consists of a practical assignment that includes a project brief including drawing and diagrams as necessary along with several tasks for you to complete.

SAMPLE

Intentionally blank

SAMPLE

2. Candidate Guidance

General guidance

This is a formal assessment that you will be marked and graded on. You will be marked on the quality and accuracy of the work you produce. It is therefore important that you carry your work out to the highest standard you can.

Plagiarism

This is an assessment of your abilities, so the work must be all your own work and carried out under the conditions stated. You will be asked to sign a declaration that you have not had any help with the assignment.

Your tutor is allowed to give you some help understanding the instructions, if necessary, but they will record any other guidance you need, and this will be taken into account during marking.

Plagiarism is the failure to acknowledge sources properly and/or the submission of another person's work as if it were your own. Plagiarism is not allowed in this project.

Where research is allowed, your tutor must be able to identify which work you have done yourself, and what you have found from other sources. It is therefore important to make sure you acknowledge sources used and clearly reference any information taken from them.

Timings and planning

You are advised to study the details of the assessment before starting.

You should check with your tutor that you have all the relevant materials, equipment and information/data sources that you need before starting the assessment.

You should take care when planning to make sure you have divided the time available between parts of the assignment tasks appropriately. Timings for tasks are provided within this pack to support with planning and time allocation.

If you have a good reason for needing more time, you will need to explain the reasons to your tutor and agree a new deadline date. Changes to dates will be at the discretion of the tutor, and they may not mark work that is handed in after the agreed deadlines.

If you have a good reason for needing more time, you will need to explain the reasons to your tutor, and this must be agreed by City & Guilds.

Health and Safety

You must always work safely, in particular while you are carrying out practical tasks.

You must always follow any relevant Health and Safety regulations, Risk Assessments and codes of practice in line with centre requirements.

If your tutor sees you working in a way that is unsafe for yourself or others, they will highlight the issue and ask you to stop the task immediately. Your tutor will not be able to reassess you until they are sure you are ready for assessment and can work safely.

Presentation of work

Presentation of work must be appropriate to the task.

You should make sure that each piece of evidence including any forms are clearly labelled with your name and the project reference.

All electronic files must be given a clear file name that allows your tutor to identify it as your work.

Written work may be word-processed or handwritten unless stated otherwise.

All sketches and drawings should be neat and tidy, to scale and annotated.

Calculations should be set out clearly, with all working shown, as well as any assumptions made. You should use appropriate units at all times, consistent with the requirements of the assignment.

Instructions for this assignment

Ensure you read all the provided assessment information contained in this candidate pack.

You must work independently and not share your work with any other candidates in these supervised assessment sessions.

Your work will be kept secure during any supervised breaks that are taken.

Internet access is not allowed.

You must complete all the tasks and present all evidence that is detailed in each task.

This assessment booklet contains:

- An assignment brief
- Task 1
- Task 2
- Task 3
- Task 4

Within each task you will find the following:

Conditions of assessment: This will tell you the duration and rules you must follow when completing a task.

What must be produced for marking: This describes the evidence you must submit when the task is completed. Be aware, failure to submit any evidence requested can adversely affect your overall mark for the assessment.

Additional evidence for this task: This describes other forms of evidence that will be collected by the assessor to support the marking of your performance. This will often include, but not limited to, photographic and video evidence.

3. Assignment Brief

You have been called to a property to undertake the design, planning and installation of a refrigeration system to a pre-existing freezer room.

Your supervisor (assessor) has asked you to carry out a survey of the proposed installation.

The customer has identified the wall space that they want to locate the cooler on and the outdoor area to site the condensing unit.

The general layout of the installation is shown in **Figure 1** and **Figure 2**.

The power supply will be taken from a local isolator provided by others.

Condensate drainage will be connected to the main drain line provided by others.

Your supervisor (assessor) will notify you of the requirements of the installation and a plan of the proposed space and location of existing services where you will carry out the installation.

Whilst on site, the customer asked for an inspection of a faulty refrigeration system at the same property. After inspection, it has been identified that it requires a compressor change and a routine maintenance. You are required to discuss this with the customer and agree to carry out this work.

This assignment has a time of 28 hours.

Figure 1 – Refrigeration schematic component layout.

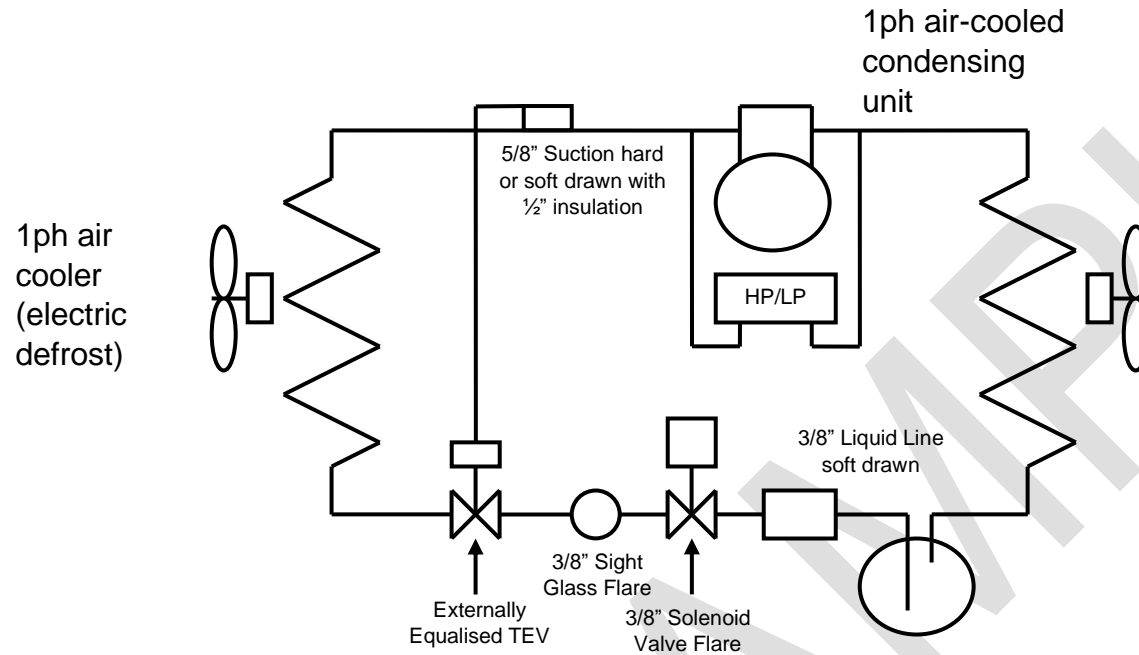
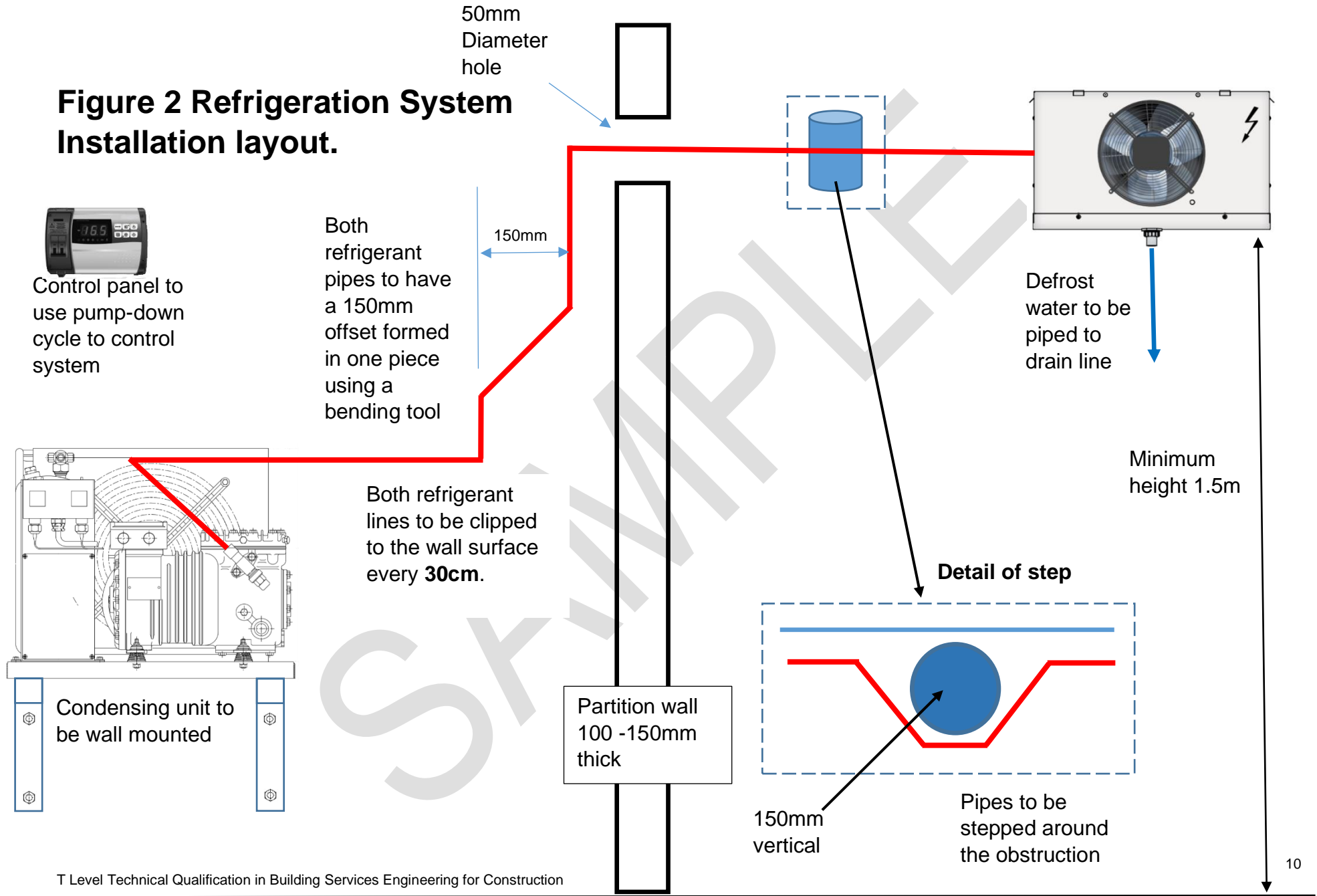

Figure 2 Refrigeration System Installation layout.



4. Tasks

Task 1 – Design

You have been asked to calculate the heat ingress for the cold store specified below.

External Dimensions: 5m long x 3.5m wide x 3.2m high.

U Values:

- Wall: 0.19 W/m²K
- Roof: 0.15 W/m²K
- Floor: 0.25 W/m²K.

Temperatures:

- Internal: -20°C
- External Ambient: 32°C
- Ground: 15°C.

Ancillary items

- Floor heater grid: 15W/m²
- Internal lighting: 300W for 8 hours per day
- Door seal heater tape: 50W
- Fan motors: 3 x 550W
- Occupancy: 2 workers for 4 hours per day
- Defrost heaters 5kW (30 minutes twice per day).

In addition, the cold store must have the capability of cooling 500kg of beef from +5°C to -20°C in 8 hours.

Using the specification for the cold room, carry out the required measurements to determine:

- a) The heat ingress
- b) The product cooling load
- c) Any additional heat loads within the cold room.

Conditions of assessment:

- The time allocated for this task is 2 hours
- You must carry out the task on your own, under controlled conditions
- No software packages are to be used in responding to task 1.

What must be produced for marking:

- A completed calculation showing all workings.

Task 2 – Planning the installation

Your assessor will provide you with a specific working area and a drawing template to ensure the dimensions meet the centre's resources. You must ensure the drawing is applicable to the location you are being assessed in and all plans are to a suitable scale.

- a) Plan the installation of the refrigeration system as per Figures 1 and 2.
- b) Measure and mark out work area as detailed in your plan.

Conditions of assessment:

- The time allocated for this task is 3 hours
- You must carry out the task on your own, under controlled conditions.

What must be produced for marking:

- Risk assessment
- Method statement with justifications
- Scale drawing of proposed working area
- Materials list
- Tools list
- PPE list.

Task 3 – Install and Commission

- a) Carry out the installation of the refrigeration system in accordance with your drawing and as agreed by your assessor.
- b) All pipework is to be pressure tested (strength and tightness).
- c) Connect the electrical supply and interconnecting wiring to the refrigeration system and condensate pump from a suitably supplied electrical isolator.
- d) Commission the system.
- e) Once commissioning is complete, you are required to hand over to customer.

Conditions of assessment:

- The time allocated for this task is 15 hours
- You must carry out the task on your own, under controlled conditions.

What must be produced for marking:

- Completed installation
- Pressure test certificate
- Commissioning checklist
- Hand over the system to the client.

Additional evidence for this task:

Assessor observations: the installation of the system including the use of tools and working to tolerances, safe isolation procedure, pressure testing.

Photographic evidence: the installation of the system.

Task 4 – Service and maintenance

- a) Diagnose faults on three compressors provide by your assessor.
- b) Replace and refit compressor from a designated system as agreed by the assessor.
- c) Carry out routine maintenance on a refrigeration system.
- d) Produce a maintenance report to include details of the fault, methods for repair and chosen method of repair with reasoning.

Conditions of assessment:

- The time allocated for this task is 8 hours
- You must carry out the task on your own, under controlled conditions.

What must be produced for marking:

- Completed compressor replacement
- Completed maintenance activity
- A full service and maintenance report, also detailing the identification of the compressor faults
- F-Gas log sheet, waste transfer note, pressure test certificate

Additional evidence for this task:

Assessor observation: fault diagnosis, replacement of compressor, routine maintenance.

Photographic evidence: service and maintenance activities.

End of Assessment

SAMPLE

Copyright in this document belongs to, and is used under licence from, the Institute for Apprenticeships and Technical Education, © 2020.

'T-LEVELS' is a registered trade mark of the Department for Education.

'T Level' is a registered trade mark of the Institute for Apprenticeships and Technical Education.

'Institute for Apprenticeships & Technical Education' and logo are registered trademarks of the Institute for Apprenticeships and Technical Education.