



6720-504 JUNE 2018

Level 2 Technical Award in Designing and Planning the Built Environment

Level 2 – Designing and Planning the Built Environment
Theory exam

If provided, stick your candidate barcode label here.

Friday 22 June 2018
09:30 – 11:30

Candidate name (first, last)

First

Last

Candidate enrolment number

Date of birth (DDMMYYYY)

Gender (M/F)

Assessment date (DDMMYYYY)

Centre number

Candidate signature and declaration*

• If any additional answer sheets are used, enter the additional number of pages in this box.

• Please ensure that you **staple** additional answer sheets to the **back** of this answer booklet, clearly labelling them with your full name, enrolment number, centre number and qualification number in BLOCK CAPITALS.

• All candidates need to use a **black/blue pen**. **Do not** use a pencil or gel pen.

• If provided with source documents, these documents **will not** be returned to City & Guilds, and will be shredded. **Do not** write on the source documents.

***I declare that I had no prior knowledge of the questions in this assessment and that I will not divulge to any person any information about the questions.**

You should have the following for this examination

- a pen with blue or black ink
- a non-programmable calculator

General instructions

This question paper is the property of City and Guilds of London and should be returned after the examination.

- This examination contains **18** questions. Answer **all** questions.
 - Answer the questions in the space provided.
 - The marks for each question are shown in brackets.
 - Show **all** calculations.



1 The list below shows different urban environments in order of increasing size. Name the **two** missing urban environments. (2 marks)

- 1. Isolated dwelling.
- 2. _____
- 3. Village.
- 4. Small town.
- 5. Large town.
- 6. _____

2 Identify **two** local amenities that can enhance physical wellbeing. (2 marks)

3 Identify **two** factors that support a sustainable community. (2 marks)

4 Explain why it is important to maintain a balance between public and private housing stock. (7 marks)

5 Describe **one** aesthetic consideration an architect **must** consider when designing a new property in a town centre. (2 marks)

6 Describe what is meant by an 'SIP system'. (2 marks)

7 Complete the table shown in Figure 1 by stating a primary **and** secondary function for external walls and external doors. (4 marks)

	Primary function	Secondary function
External walls		
External doors		

Figure 1

8 State the planning permission considerations when planning to demolish a historic building. (2 marks)

- 9 Identify **two** documents, other than drawings, that would be submitted with a planning application for a large development. (2 marks)

- 10 Summarise the key factors that can affect a material specification. (4 marks)

- 11 Describe the common cause for the deteriorating brickwork in Figure 2. (2 marks)



Figure 2

12 Describe the benefits of using structural steel frames in the retail sector.

(3 marks)

13 Compare the performance of timber and concrete as structural framing materials in terms of strength and durability.

(4 marks)

14 Identify the following construction materials shown in Figure 3.

(3 marks)



a



b



c

Figure 3

- a) _____
- b) _____
- c) _____

15 State **two** benefits of using a model to present a design to a client.

(2 marks)

- 16 Calculate the area of flooring materials required for the property in Figure 4. Allow 10% for wastage within your answer. You **must** show all your working out.

(4 marks)

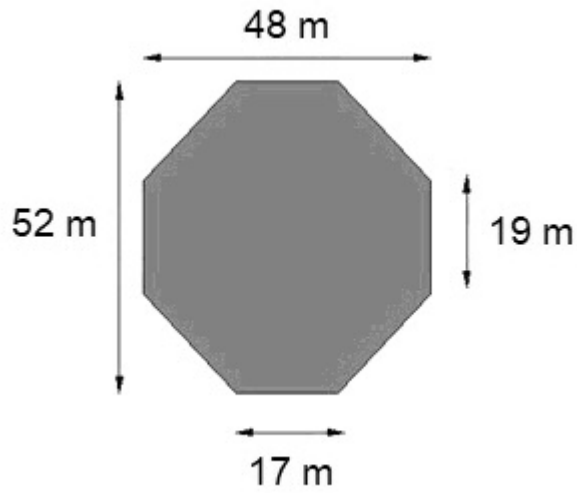

Figure 4

- 17 Explain the differences between presentation drawings and working drawings.

(4 marks)
