

6804 Awards and Certificates in Construction Trade Occupations at SCQF Level 4

September 2014 Version 1.2

Contents

Task manual amendments	1
Candidate details	2
Unit assessment overview	3
Practical task completion record	3
Instructions to candidates	6
Unit 102 Construction trade occupations – painting and decorating	7
Task 1 Prepare previously painted surfaces and apply paint systems	7
Unit 103 Construction Trade Occupations - Plastering	9
Task 1 Fix plasterboards	9
Task 2 Apply plaster to vertical surfaces	11
Unit 104 Construction Trade Occupations - Plumbing	13
Task 1 Prepare, set out and fix plumbing components	13
Unit 105 Construction Trade Occupations - Bricklaying	15
Task 1 Prepare, cut and lay bricks and blocks to level and line	15
Unit 106 Construction Trade Occupations - Tiling	18
Task 1 Apply and finish tiling to vertical surfaces and restore the work area on completion of task	18
Unit 107 Construction Trade Occupations - Carpentry	20
Task 1 Prepare and fix door ironmongery	20
Task 2 Prepare and fix skirting	22
Unit 108 Handle and Store Construction Materials and Components	24
Task 1 Receive a delivery correctly	24
Task 2 Handle and store construction materials and components correctly	25
Drawings and diagrams	27
Unit 102 Construction Trade Occupations – Painting and Decorating	27
Unit 103 Construction Trade Occupations - Plastering	28
Unit 105 Construction Trade Occupations - Bricklaying	30
Unit 106 Construction Trade Occupations - Tiling	31
Unit 107 Construction Trade Occupations - Carpentry	32
Unit 108 Handle and Store Construction Materials and Components	35

Task manual amendments

Amendments since version 1.0

Page 31 Unit 106, Figure 1 Tiling task drawing and specification amended.

Final page Phone numbers removed

Candidate details



This *Practical task manual* is a record of your achievement in practical assessments. You must keep it in good condition and it must be stored in a safe place by your Assessor.

Please fill in all of your details before you carry out any assessments.

Candidate Details

Surname		Forename(s)	
---------	--	-------------	--

City & Guilds enrolment number	
--------------------------------	--

Centre Details

Name		Centre No	
------	--	-----------	--

I understand the requirements of the qualification and that all the work towards the assessments must be my own.

Candidate signature (please print)	
----------------------------------------------	--

Assessor name (please print)		Signed	
----------------------------------------	--	--------	--

Date	
------	--

Unit assessment overview

Practical task completion record

To be completed by Assessor:

For each task, the points for each grade are
 Pass = 1, Merit = 2, and Distinction = 3 points.

Where there is a weighting given, (see *Assessor guide*: unit assessment overview) multiply the points by the weighting to be applied (eg to apply a weighting of 2, a distinction is: $3 \times 2 = 6$ points). Do not include pass/fail only tasks in the calculation, only graded.

Conversion chart	
Average	Overall Grade
1 – 1.5	Pass
1.6 – 2.5	Merit
2.6 – 3	Distinction

†All tasks must be passed for the unit to be achieved.

Unit 102 Construction Trade Occupations – Painting and Decorating

Task	Grade for task
1 Prepare previously painted surfaces and apply paint systems	P / M / D / X
End of unit knowledge test	P / X

Assessor signature and date:

The overall grade will be the same as the single graded task in this unit.

Overall grade

Unit 103 Construction Trade Occupations - Plastering

Task	Grade for task [†]	Points (graded tasks)
1 Fix plasterboards	P / M / D / X	
2 Apply plaster to vertical surfaces	P / M / D / X	
End of unit knowledge test	P / X	
Total		
For graded tasks, divide total points by total number of graded tasks		÷ 2
Average =		
Overall grade (see conversion chart)		

Assessor signature and date:

Unit 104 Construction Trade Occupations – Plumbing

Task	Grade for task
1 Prepare, set out and fix plumbing components	P / X
End of unit knowledge test	P / X

Assessor signature and date:	Candidates must pass all tasks, and the end of unit knowledge test, for this unit to achieve a pass grade overall.	Overall grade
		<input style="width: 100%;" type="text"/>

Unit 105 Construction Trade Occupations – Bricklaying

Task	Grade for task
1 Prepare, cut and lay bricks and blocks to level and line	P / M / D / X
End of unit knowledge test	P / X

Assessor signature and date:	The overall grade will be the same as the single graded task in this unit.	Overall grade
		<input style="width: 100%;" type="text"/>

Unit 106 Construction Trade Occupations - Tiling

Task	Grade for task
1 Apply and finish tiling to vertical surfaces and restore the work area on completion of task	P / X
End of unit knowledge test	P / X

Assessor signature and date:	Candidates must pass all tasks, and the end of unit knowledge test, for this unit to achieve a pass grade overall.	Overall grade
		<input style="width: 100%;" type="text"/>

Unit 107 Construction Trade Occupations - Carpentry

Task	Grade for task†	Weighting for task	Weighted Points
1 Prepare and fix door ironmongery	P / M / D / X	2	
2 Prepare and fix skirting	P / M / D / X	1	
End of unit knowledge test	P / X		
Total			
For graded tasks, divide total points by total of weightings			÷ 3
Average =			
Overall grade (see conversion chart)			

Assessor signature and date:

Unit 108 Handle and Store Construction Materials and Components

Task	Grade for task
1 Receive a delivery correctly	P / X
2 Handle and store construction materials and components correctly	P / X
End of unit knowledge test	P / X

Assessor signature and date:

Candidates must pass all tasks, and the end of unit knowledge test, for this unit to achieve a pass grade overall.

Overall grade

Authenticity and IQA/QC sampling

The assessor's signature on individual tasks will be taken as assurance that the judgements recorded are made on authentic candidate work produced under appropriate conditions. Please complete the declaration below to confirm this is the case.

I confirm that all tasks were conducted under conditions designed to assure the authenticity of the candidate's work, and am satisfied that, to the best of my knowledge, the work assessed was solely that of the candidate.

I have judged all assessments against the relevant assessment and grading criteria and award the candidate the unit grades as calculated above.

Assessor signature	Date
*IQA signature and date	*QC signature and date

*IQA and QC signatures attest to the evidence available on the recorded date(s).

Instructions to candidates

About this document

This *Practical task manual* contains all of the practical assessment for 6704 Awards and Certificates in Construction Trade Occupations at SCQF Level 4.

Practical tasks

These tasks let you show your practical skills and are usually graded pass, merit or distinction – a few are pass only. These tasks will be assessed by your assessor watching how you carry out the tasks and checking your final pieces of work.

Before you carry out the task you will be told how it will be assessed and you should read the observation checklist at the end of each task so you know what you need to do to get each grade.

You can ask your assessor for help in understanding the task instructions, but all of the work must be your own.

Health and safety

You must use safe working practices at all times.

You are responsible for your own safety and the safety of others. If you behave in an unsafe way, you will be stopped and given a warning. If you do not meet all of the Health and Safety requirements, the assessment will be stopped. Your assessor will not be able to let you try the task again until they are sure you can work safely.

Time considerations

Each task shows how long it is likely to take. This is for guidance and so you can plan your work. If you have a good reason for needing more time you must explain this to your assessor as soon as possible so they can decide whether you can have more time.

Security

Where an assignment is taken over more than one session, all documentation, paperwork and work products must be labelled carefully with your name and kept securely at the centre. Your assessor will give you directions about how to leave your work.

Opportunities to repeat tasks

The tasks are 'end tests' so you will only be asked to take the assessment when you have had the chance to do all of the learning and practice you need. You will be able to try the whole task again if you do not pass, but you will not be able to take the assessment again just to try to get a better grade.

Feedback

As well as telling you the result for the task your assessor will give you feedback. They will give you a feedback sheet with details of what you could do to improve, and also what you did well in. This will help you to prepare for other assessments or to retake the assessment if you need to.

Unit 102 Construction trade occupations – painting and decorating

Task 1 Prepare previously painted surfaces and apply paint systems

Expected time	4 hours and 30 minutes
Task instructions	<ul style="list-style-type: none"> • Select the correct method of preparation for a previously painted surface. • Prepare the surface to an acceptable level. • Apply a chosen paint system to the chosen area. • Maintain a tidy work area at all times. • Follow current environmental and relevant health and safety regulations at all times.
Diagrams	Figure 1: Example of surface - pg 27

Observation checklist

AC	The candidate has	Pass	Merit	Distinction
4.1	prepared the surface to receive paint systems :			
4.1	identified the correct method of surface preparation for the chosen area	<input type="checkbox"/>		
4.2	<ul style="list-style-type: none"> • selected and used the tools and equipment correctly while preparing the area 	<input type="checkbox"/> Used tools in the correct way to achieve the required standard	<input type="checkbox"/> Used tools correctly and did not waste abrasive material	
	<ul style="list-style-type: none"> • removed and filled surface defects 	<input type="checkbox"/> Removed defects to most of the surface	<input type="checkbox"/> Removed defects from all surface areas	<input type="checkbox"/> Removed defects from all surface areas without guidance
	<ul style="list-style-type: none"> • removed residual surface contamination 	<input type="checkbox"/>		
	<ul style="list-style-type: none"> • cleaned surface area in preparation of application 	<input type="checkbox"/> Surface cleaned with minimal guidance	<input type="checkbox"/> Surface cleaned without guidance	
6.1	<ul style="list-style-type: none"> • applied paint systems to surfaces: 			

AC	The candidate has	Pass	Merit	Distinction
	<ul style="list-style-type: none"> • surface is fully covered with paint 	<input type="checkbox"/> Surface is covered with minor misses	<input type="checkbox"/> Surface is covered with no misses	<input type="checkbox"/> Surface is covered evenly with no misses
	<ul style="list-style-type: none"> • no runs visible from 1 metre by brush 	<input type="checkbox"/>		
	<ul style="list-style-type: none"> • paint cut in neatly 	<input type="checkbox"/> ± 3 mm Over or under lapping	<input type="checkbox"/> ±2 mm Over or under lapping	<input type="checkbox"/> ±1 mm Over or under lapping
	<ul style="list-style-type: none"> • no evidence of skidding and fat edges visible from 1 metre by roller 	<input type="checkbox"/>		
8.1	ensured the work area, tools and equipment are maintained during and are left clean and tidy on completion of painting and decorating activities	<input type="checkbox"/>		
8.2	disposed of waste safely and in accordance with legislation and official guidance	<input type="checkbox"/>		
4.3, 6.2	followed current environmental and relevant health and safety regulations	<input type="checkbox"/>		

Task grading rules		Task grade:
To award a pass : every activity in the checklist must be successfully achieved.		
To award a merit : in addition to the above, 4 out of 5 graded activities in the checklist must be achieved to at least a merit standard.		
To award a distinction : 2 out of 5 graded activities in the checklist must be achieved to at least a distinction standard, and 3 of the remaining graded activities must be achieved to at least a merit standard.		
Assessor	Signature & Date	

Unit 103 Construction Trade Occupations - Plastering

Task 1 Fix plasterboards

Expected time	1 hour and 30 minutes
Task instructions	<ul style="list-style-type: none"> • Refer to the two diagrams provided. • Select materials and equipment for fixing plasterboards. • Measure, cut and fix plasterboards to timber studwork. • Make efforts to minimise waste of materials. • Maintain a tidy work area at all times and on completion of the task. • Follow current environmental and relevant health and safety regulations at all times. • Dispose of waste safely and in accordance with legislation and official guidance.
Diagrams	<p>Figure 1: Timber stud partition showing suggested positioning of plasterboard - page 28</p> <p>Figure 2: Timber stud partition with plasterboard fixed and setting coat - page 29</p>

Observation checklist

AC	The candidate has	Pass	Merit	Distinction
5.1	selected the <ul style="list-style-type: none"> • materials • equipment to be used to carry out fixing plasterboards	<input type="checkbox"/>		
5.2	applied the procedures for fixing plasterboards safely procedures include: <ul style="list-style-type: none"> • measuring • cutting • rasping • staggering • fixing • aligning 	<input type="checkbox"/> Boards measured, cut, fixed, staggered and aligned correctly		
		<input type="checkbox"/> Used correct fixings but not aligned	<input type="checkbox"/> The majority are aligned along the stud	<input type="checkbox"/> All fixings aligned along the stud
		<input type="checkbox"/> Fixing centres within $\pm 11-20$ mm and majority to correct depth	<input type="checkbox"/> Fixing centres within $\pm 4-10$ mm and majority to correct depth	<input type="checkbox"/> Fixing centres accurate (± 3 mm) and majority to correct depth
		<input type="checkbox"/> All joints butted	<input type="checkbox"/> All joints between 3-5 mm	<input type="checkbox"/> All joints between 2-3 mm

AC	The candidate has	Pass	Merit	Distinction
		<input type="checkbox"/> Finished plasterboard surface contains minor imperfections	<input type="checkbox"/> Finished plasterboard surface contains no imperfections	
5.3	used correct methods to minimise waste and damage to the surrounding area when carrying out work activities	<input type="checkbox"/> Task completed, but minimal attempts made to minimise waste	<input type="checkbox"/> Task completed with some waste, but attempts were made to minimise	<input type="checkbox"/> Task completed with no, or limited waste
5.4	follow current environmental and relevant health and safety regulations relating to fixing plasterboards	<input type="checkbox"/>		
9.1	ensured the work area, tools and equipment are left clean and tidy on completion of plastering activities	<input type="checkbox"/>		
9.2	disposed of waste safely and in accordance with legislation and official guidance	<input type="checkbox"/>		

Task grading rules		Task grade:
To award a pass : every activity in the checklist must be successfully achieved.		
To award a merit : in addition to the above, all 5 graded activities in the checklist must be achieved to at least a merit standard.		
To award a distinction : in addition to both of the above, all 4 out of 5 graded activities in the checklist must be achieved to a distinction standard and the remaining graded activity must be achieved to at least a merit standard.		
Assessor	Signature & Date	

Unit 103 Construction trade occupations - plastering

Task 2 Apply plaster to vertical surfaces

Expected time	1 hour and 30 minutes
Task instructions	<ul style="list-style-type: none"> • Refer to the second diagram provided in task 1. • Mix setting plaster. • Apply setting coat to plasterboard in two applications. • Maintain a tidy work area at all times and on completion of the task. • Follow current environmental and relevant health and safety regulations at all times. • Dispose of waste safely and in accordance with legislation and official guidance.
Diagrams	Figure 2: Timber stud partition with plasterboard fixed and setting coat - page 29

Observation checklist

AC	The candidate has	Pass	Merit	Distinction
7.1	mixed setting plasters mixing to include: <ul style="list-style-type: none"> • cleanliness of tools and equipment • cleanliness of mixing area • sequence of mixing 	<input type="checkbox"/> Mixed finishing plaster required to the correct consistency with guidance	<input type="checkbox"/> Mixed finishing plaster required to the correct consistency with minimal guidance	<input type="checkbox"/> Mixed finishing plaster required to the correct consistency without guidance
7.2	applied scrim (self-adhesive) to joints	<input type="checkbox"/>		
7.3	applied setting coat to vertical surfaces application to include: <ul style="list-style-type: none"> • first application • second application • trowelling and finishing 	<input type="checkbox"/> Applied all coats to surface evenly and to correct thickness		
		<input type="checkbox"/> Contains some imperfections and blemishes	<input type="checkbox"/> Minor imperfections and blemishes	<input type="checkbox"/> Free from imperfections and blemishes
		<input type="checkbox"/> Flat finished surface	<input type="checkbox"/> Flat and smooth finished surface	<input type="checkbox"/> Flat and smooth finished surface and uniform in appearance

AC	The candidate has	Pass	Merit	Distinction
		<input type="checkbox"/> Worked methodically at times during the application process	<input type="checkbox"/> Worked methodically through the majority of application process	<input type="checkbox"/> Worked methodically through the entire application process
7.4	followed current environmental and relevant health and safety regulations relating to applying plaster to vertical surfaces	<input type="checkbox"/>		
9.1	ensured the work area, tools and equipment are left clean and tidy on completion of plastering activities	<input type="checkbox"/>		
9.2	disposed of waste safely and in accordance with legislation and official guidance	<input type="checkbox"/>		

Task grading rules	Task grade:
To award a pass : every activity in the checklist must be successfully achieved.	
To award a merit : in addition to the above, all 4 graded activities in the checklist must be achieved to at least a merit standard.	
To award a distinction : in addition to both of the above, all 4 graded activities in the checklist must be achieved to a distinction standard.	
Assessor	Signature & Date

Unit 104 Construction Trade Occupations - Plumbing

Task 1 Prepare, set out and fix plumbing components

Expected time	3 hours
Task instructions	<ul style="list-style-type: none"> • List the tools and materials required for each activity. • Prepare for, set out and fix plumbing components: <ul style="list-style-type: none"> ○ Activity A: Fix taps and waste fitting to a pedestal wash hand basin. The basin is to be stood on the pedestal in the required position and fixed to the wall, level and plumb as instructed. ○ Activity B: Connect hot and cold supplies to the basin from pre-installed pipework tails. ○ Activity C: Fit a waste trap and install push-fit waste pipe. If necessary, the pipework should be clipped to the wall. • On completion of the task, the work will be tested for soundness by the assessor. • Maintain a tidy work area at all times and on completion of each activity and the overall task. • Follow current environmental and relevant health and safety regulations at all times. • Dispose of waste safely and in accordance with legislation and official guidance.

Observation checklist

AC	The candidate has	Pass	Merit	Distinction
4.1	completed tools and materials list from given specification complete the resource checklist for each activity	<input type="checkbox"/>		
4.2	set out in accordance with given specification and work instructions	<input type="checkbox"/>		
4.3	positioned and fixed plumbing components to a given specification A. position basin, fix taps and waste fittings B. connect hot and cold supplies C. fit waste trap and install push fit waste pipe	<input type="checkbox"/> A. Basin correctly dressed and level B. Hot and cold supplies tested C. Waste connections tested		
6.1	ensured the work area, tools and equipment were left clean and tidy on completion of plumbing activities	<input type="checkbox"/>		
6.2	disposed of waste safely and in accordance with legislation and official guidance	<input type="checkbox"/>		

Task grading rules	Task grade:
To award a pass : every activity in the checklist must be successfully achieved.	
Assessor Signature & Date	

Unit 105 Construction Trade Occupations - Bricklaying

Task 1 Prepare, cut and lay bricks and blocks to level and line

Expected time	6 hours
Task instructions	<ul style="list-style-type: none"> • Interpret drawings and specifications. • Complete a risk assessment. • Complete a resource checklist. • Set out the walls. • Position the materials ready for use. • Build the walls. • Maintain a tidy work area at all times. • Follow current environmental and relevant health and safety regulations at all times.
Diagrams	Figure 1: Example of plan view of brickwall and blockwall - page 30

Observation checklist

AC	The candidate has	Pass	Merit	Distinction
8.2, 8.4	correctly completed the risk assessment necessary to carry out the task: a minimum of two hazards identified	<input type="checkbox"/>		
4.1, 8.2	completed tools, materials and equipment list from given specification	<input type="checkbox"/>		
4.2	set out in accordance with given specification and work instructions: set out the working area and walls	<input type="checkbox"/>		
6.1	<ul style="list-style-type: none"> • selected the correct materials, components and equipment for construction and bricklaying operations • correctly answered gauge and mix question 	<input type="checkbox"/>		
8.1	correctly used materials, tools and equipment during the building of the wall	<input type="checkbox"/>		
8.2	measured , marked and cut correctly length of cuts	<input type="checkbox"/> ± 3mm		
8.3	Profiles fixed accurately and in line	<input type="checkbox"/>		
	laid bricks in accordance to the given specifications:			
	<ul style="list-style-type: none"> • accurate length of wall 	<input type="checkbox"/> ±6mm	<input type="checkbox"/> ±4mm	<input type="checkbox"/> ±2mm
	<ul style="list-style-type: none"> • gauge 	<input type="checkbox"/> ±6mm	<input type="checkbox"/> ±4mm	<input type="checkbox"/> ±2mm

AC	The candidate has	Pass	Merit	Distinction
	<ul style="list-style-type: none"> level 	<input type="checkbox"/> ±6mm	<input type="checkbox"/> ±4mm	<input type="checkbox"/> ±2mm
	<ul style="list-style-type: none"> plumb to 3 points 	<input type="checkbox"/> ±6mm	<input type="checkbox"/> ±4mm	<input type="checkbox"/> ±2mm
	<ul style="list-style-type: none"> ranging 	<input type="checkbox"/> ±6mm	<input type="checkbox"/> ±4mm	<input type="checkbox"/> ±2mm
	<ul style="list-style-type: none"> maintained vertical perp ends 	<input type="checkbox"/> ±6mm	<input type="checkbox"/> ±4mm	<input type="checkbox"/> ±2mm
	<ul style="list-style-type: none"> all joint full and complete 	<input type="checkbox"/>		
	<ul style="list-style-type: none"> jointed correctly 	<input type="checkbox"/>		
	laid blocks bricks in accordance to the given specifications:			
	<ul style="list-style-type: none"> accurate length of wall 	<input type="checkbox"/> ±6mm	<input type="checkbox"/> ±4mm	<input type="checkbox"/> ±2mm
	<ul style="list-style-type: none"> gauge 	<input type="checkbox"/> ±6mm	<input type="checkbox"/> ±4mm	<input type="checkbox"/> ±2mm
	<ul style="list-style-type: none"> level 	<input type="checkbox"/> ±6mm	<input type="checkbox"/> ±4mm	<input type="checkbox"/> ±2mm
	<ul style="list-style-type: none"> plumb to 3 points 	<input type="checkbox"/> ±6mm	<input type="checkbox"/> ±4mm	<input type="checkbox"/> ±2mm
	<ul style="list-style-type: none"> ranging 	<input type="checkbox"/> ±6mm	<input type="checkbox"/> ±4mm	<input type="checkbox"/> ±2mm
	<ul style="list-style-type: none"> maintained vertical perp ends 	<input type="checkbox"/> ±6mm	<input type="checkbox"/> ±4mm	<input type="checkbox"/> ±2mm
	<ul style="list-style-type: none"> all joint full and complete 	<input type="checkbox"/>		
	<ul style="list-style-type: none"> jointed correctly 	<input type="checkbox"/>		
10.1	ensured the work area, tools and equipment are left clean and tidy on completion of bricklaying activities	<input type="checkbox"/>		
10.2	disposed of waste safely and in accordance with legislation and official guidance	<input type="checkbox"/>		
8.2, 8.4	carried out activities safely and in accordance with Health and Safety legislation	<input type="checkbox"/>		

Task grading rules		Task grade:
To award a pass : every activity in the checklist must be successfully achieved.		
To award a merit : in addition to the above, 7 out of 12 graded activities in the checklist must be achieved to at least a merit standard.		
To award a distinction : 7 out of 12 graded activities in the checklist must be achieved to at least a distinction standard, and the 5 remaining graded activities must be achieved to at least a merit standard.		
Assessor	Signature & Date	

Unit 106 Construction Trade Occupations - Tiling

Task 1 Apply and finish tiling to vertical surfaces and restore the work area on completion of task

Expected time	6 hours
Task instructions	<ul style="list-style-type: none"> • Fix tiles and trims to wall area. • Complete Resource Checklist, select and calculate correct materials required to tile area including 10% waste. • Check backgrounds for suitability, level/flat/plumb/free of dust. • Set out window wall using centring method. • Cut and fix tiles and trims ensuring solid bed is fixed, level and plumb. • Grout and finish wall tiling including polishing clean. • Install sealant joint to tile/bench intersection. • Ensure the area is clean and tidy on completion of task. • Maintain tools and equipment on completion of task. • Ensure all relevant environmental and health and safety regulations are followed.
Diagrams	Figure 1: Example of completed tiled kitchen wall area and specification - page 31

Observation checklist

AC	The candidate has	Pass	Merit	Distinction
4.1	completed Resource Checklist	<input type="checkbox"/>		
4.3	selected materials, accessories and equipment	<input type="checkbox"/>		
4.4	checked accuracy of spirit level(s) and straight edge checked backgrounds for suitability: <ul style="list-style-type: none"> • level/flat/plumb/free of dust 	<input type="checkbox"/>		
4.2	cut tiles safely to meet specification	<input type="checkbox"/>		
4.5	fixed tiles according to specification and manufacturers' guidance	<input type="checkbox"/>		
4.6	followed current environmental and health and safety regulations for preparing and fixing tiles	<input type="checkbox"/>		
6.1	ensured work area, tools and equipment left clean and tidy on completion of task	<input type="checkbox"/>		
6.2	disposed of waste safely in accordance with legislation and official guidance	<input type="checkbox"/>		

Task grading rules	Task grade:
To award a pass : every activity in the checklist must be successfully achieved.	
Assessor Signature & Date	

Unit 107 Construction Trade Occupations - Carpentry

Task 1 Prepare and fix door ironmongery

Expected time	2 hours
Task instructions	<ul style="list-style-type: none"> • Complete a tool list. • Fit sash mortice lock. • Fit door handles. • Fit striker plate on the door jamb. • Maintain a tidy work area at all times. • Follow current environmental and relevant health and safety regulations at all times.
Diagrams	Figure 1: Door with handles and lock - page 32 Figure 2: Door jamb with striker plate - page 33

Observation checklist

AC	The candidate has	Pass	Merit	Distinction
4.1	completed a tools resource checklist and selected the tools required for fixing a door	<input type="checkbox"/>		
4.2	fit sash mortice lock	<input type="checkbox"/>		
	<ul style="list-style-type: none"> • selected correct lock and handing 			
	<ul style="list-style-type: none"> • height of lock 990 mm to centre of spindle 	<input type="checkbox"/> ±3 mm	<input type="checkbox"/> ± 2 mm	<input type="checkbox"/> ±1 mm
	<ul style="list-style-type: none"> • selected correct auger bit size 	<input type="checkbox"/>		
	<ul style="list-style-type: none"> • mortice cut to suit lock 	<input type="checkbox"/> within 4 mm	<input type="checkbox"/> within 3 mm	<input type="checkbox"/> within 2 mm
	<ul style="list-style-type: none"> • cut out for faceplate 	<input type="checkbox"/> within 2 mm	<input type="checkbox"/> within 1 mm	<input type="checkbox"/> within 0.5 mm
	<ul style="list-style-type: none"> • marked and drilled for spindle and keyhole 	<input type="checkbox"/> within 3 mm	<input type="checkbox"/> within 2 mm	<input type="checkbox"/> within 1 mm
	<ul style="list-style-type: none"> • fit lock with screw heads flush 	<input type="checkbox"/>		
	<ul style="list-style-type: none"> • face plate parallel and equal to edge of door 	<input type="checkbox"/> within 2 mm	<input type="checkbox"/> within 1 mm	<input type="checkbox"/> within 0.5 mm
	<ul style="list-style-type: none"> • striker plate positioned in line with lock 	<input type="checkbox"/> ±3 mm	<input type="checkbox"/> ± 2 mm	<input type="checkbox"/> ±1 mm
	<ul style="list-style-type: none"> • striker plate parallel to edge of rebate 	<input type="checkbox"/> within 2 mm	<input type="checkbox"/> within 1 mm	<input type="checkbox"/> within 0.5 mm
	<ul style="list-style-type: none"> • cut out for striker plate within 1 mm 	<input type="checkbox"/>		

AC	The candidate has	Pass	Merit	Distinction
4.2	fit handles <ul style="list-style-type: none"> handles in line on both sides 	<input type="checkbox"/> ±3 mm	<input type="checkbox"/> ± 2 mm	<input type="checkbox"/> ±1 mm
	<ul style="list-style-type: none"> handles parallel to edge of door 	<input type="checkbox"/> within 2 mm	<input type="checkbox"/> within 1 mm	<input type="checkbox"/> within 0.5 mm
	<ul style="list-style-type: none"> handles and key operational from both sides 	<input type="checkbox"/>		
4.3	followed current environmental and relevant health and safety regulations relating to preparing and fixing door ironmongery, including <ul style="list-style-type: none"> maintaining a clean and tidy work area 	<input type="checkbox"/>		

Task grading rules		Task grade:
To award a pass : every activity in the checklist must be successfully achieved.		
To award a merit : in addition to the above, 5 out of 9 graded activities in the checklist must be achieved to at least a merit standard.		
To award a distinction : 5 out of 9 graded activities in the checklist must be achieved to at least a distinction standard, and 4 of the remaining graded activities must be achieved to at least a merit standard.		
Assessor	Signature & Date	

Unit 107 Construction Trade Occupations - Carpentry

Task 2 Prepare and fix skirting

Expected time	1 hour
Task instructions	<ul style="list-style-type: none"> • Complete a tool list. • Cut and fix skirting board to include a <ul style="list-style-type: none"> - scribe on an internal corner. - mitre on an external corner. • Maintain a tidy work area at all times. • Follow current environmental and relevant health and safety regulations at all times.
Diagrams	Figure 1: Skirting board - page 34

Observation checklist

AC	The candidate has	Pass	Merit	Distinction
6.1	completed a tools resource checklist and selected the tools required for fixing skirting	<input type="checkbox"/>		
6.2	fixed skirting using joints. <ul style="list-style-type: none"> • scribed joint 	<input type="checkbox"/> within 3 mm	<input type="checkbox"/> within 2 mm	<input type="checkbox"/> within 1 mm
	<ul style="list-style-type: none"> • scribed joint top edge level within 1 mm 	<input type="checkbox"/>		
	<ul style="list-style-type: none"> • mitre joint gap 	<input type="checkbox"/> within 3 mm	<input type="checkbox"/> within 2 mm	<input type="checkbox"/> within 1 mm
	<ul style="list-style-type: none"> • mitre joint top edge level within 1 mm 	<input type="checkbox"/>		
	<ul style="list-style-type: none"> • face mitre to external corner parallel 	<input type="checkbox"/> within 3 mm	<input type="checkbox"/> within 2 mm	<input type="checkbox"/> within 1 mm
	<ul style="list-style-type: none"> • skirting fixed with no hammer marks or splits 	<input type="checkbox"/>		
	<ul style="list-style-type: none"> • fixings punched below timber surface 	<input type="checkbox"/>		
6.3	followed current environmental and relevant health and safety regulations relating to preparing and fixing skirting including <ul style="list-style-type: none"> • maintaining a clean and tidy work area 	<input type="checkbox"/>		

Task grading rules		Task grade:
To award a pass : every activity in the checklist must be successfully achieved.		
To award a merit : in addition to the above, all 3 graded activities in the checklist must be achieved to at least a merit standard.		
To award a distinction : in addition to both of the above, all 3 graded activities in the checklist must be achieved to a distinction standard.		
Assessor	Signature & Date	

Unit 108 Handle and Store Construction Materials and Components

Task 1 Receive a delivery correctly

Expected time	30 minutes
Task instructions	<ul style="list-style-type: none"> • Check and sign for a delivery. • Record and report any faults or shortages appropriately. • Follow current environmental and relevant health and safety regulations at all times.
Diagrams	Figure 1: Delivery note - page 35

Observation checklist

AC	The candidate has	Pass	Merit	Distinction
2.1	checked the materials complied with the delivery note	<input type="checkbox"/>		
2.2	recorded and reported shortages to authorised person	<input type="checkbox"/>		
2.3	followed current environmental and relevant health and safety regulations relating to preparing for the handling and storage of construction materials and components	<input type="checkbox"/>		

Task grading rules	Task grade:
To award a pass : every activity in the checklist must be successfully achieved.	
Assessor Signature & Date	

Unit 108 Handle and Store Construction Materials and Components

Task 2 Handle and store construction materials and components correctly

Expected time	40 minutes
Task instructions	<ul style="list-style-type: none"> • Move and store the items in the delivery using correct manual handling techniques. • Move the items to the correct storage facility as instructed by your assessor. • Store the items correctly and protect them as necessary. • Maintain a tidy work area at all times and on completion of task. • Follow current environmental and relevant health and safety regulations at all times.

Observation checklist

AC	The candidate has	Pass	Merit	Distinction
4.1	stored materials and components in accordance with given instructions <ul style="list-style-type: none"> • all items 	<input type="checkbox"/>		
4.2	stored materials and components in a way that prevents hazards and enables rotation of use to include: <ul style="list-style-type: none"> • paint • cement 	<input type="checkbox"/>		
4.3	protected materials and components from the elements and damage during storage to include: <ul style="list-style-type: none"> • bricks • blocks 	<input type="checkbox"/>		
4.4	applied manual handling techniques when lifting and moving materials and components <ul style="list-style-type: none"> • all items 	<input type="checkbox"/>		
4.5	ensured the work area was left clean and tidy on completion of the delivery	<input type="checkbox"/>		
4.6	followed current environmental and relevant health and safety regulations relating to handling and storage of construction materials and components	<input type="checkbox"/>		

Task grading rules	Task grade:
To award a pass : every activity in the checklist must be successfully achieved.	
Assessor Signature & Date	

Drawings and diagrams

Unit 102 Construction Trade Occupations – Painting and Decorating

Task 1 Prepare previously painted surfaces and apply paint systems

Figure 1: Example of surface

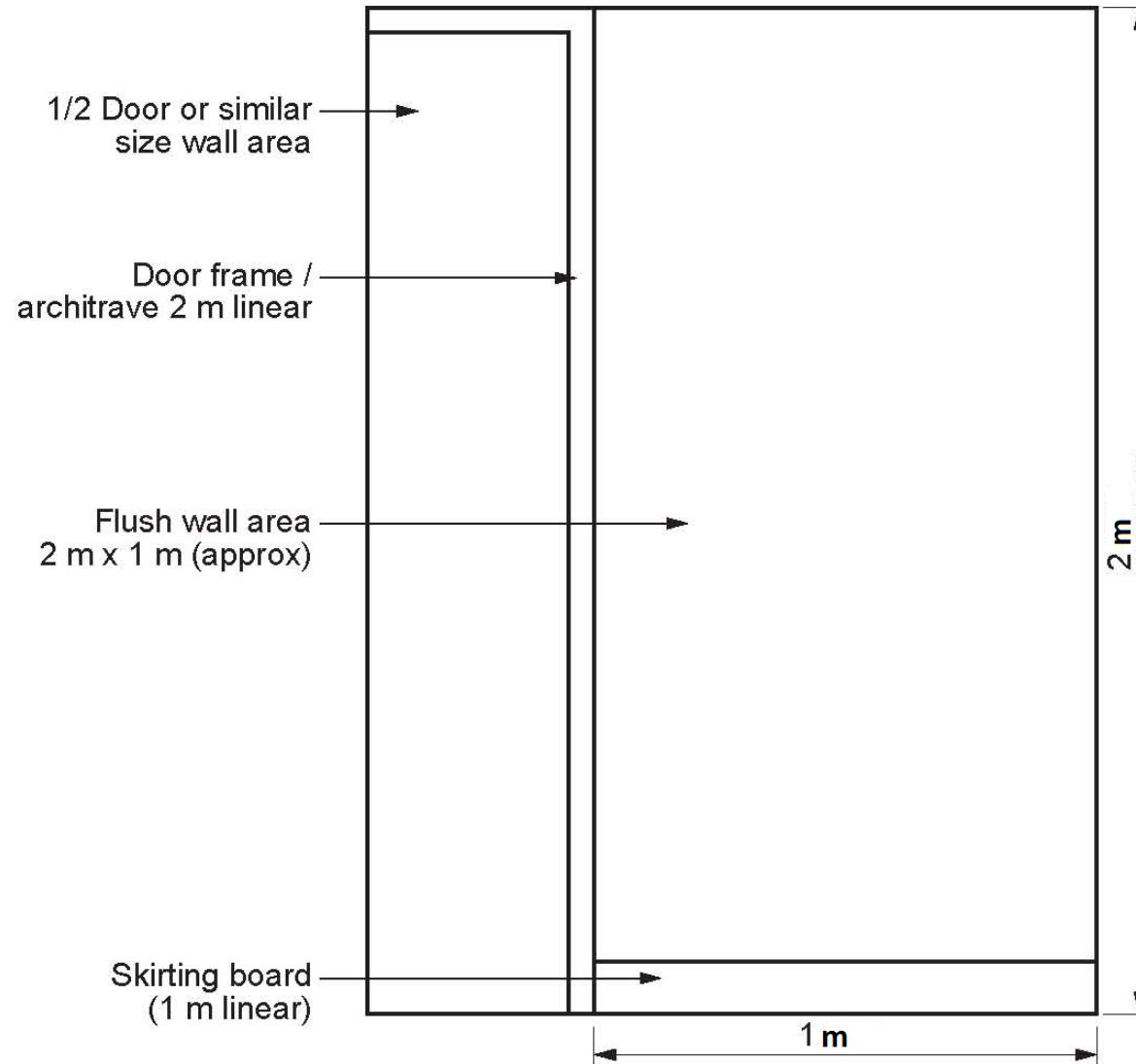

Drawings and diagrams

Unit 103 Construction Trade Occupations - Plastering

Task 1 Fix plasterboards

Figure 1: Timber stud partition showing suggested positioning of plasterboard

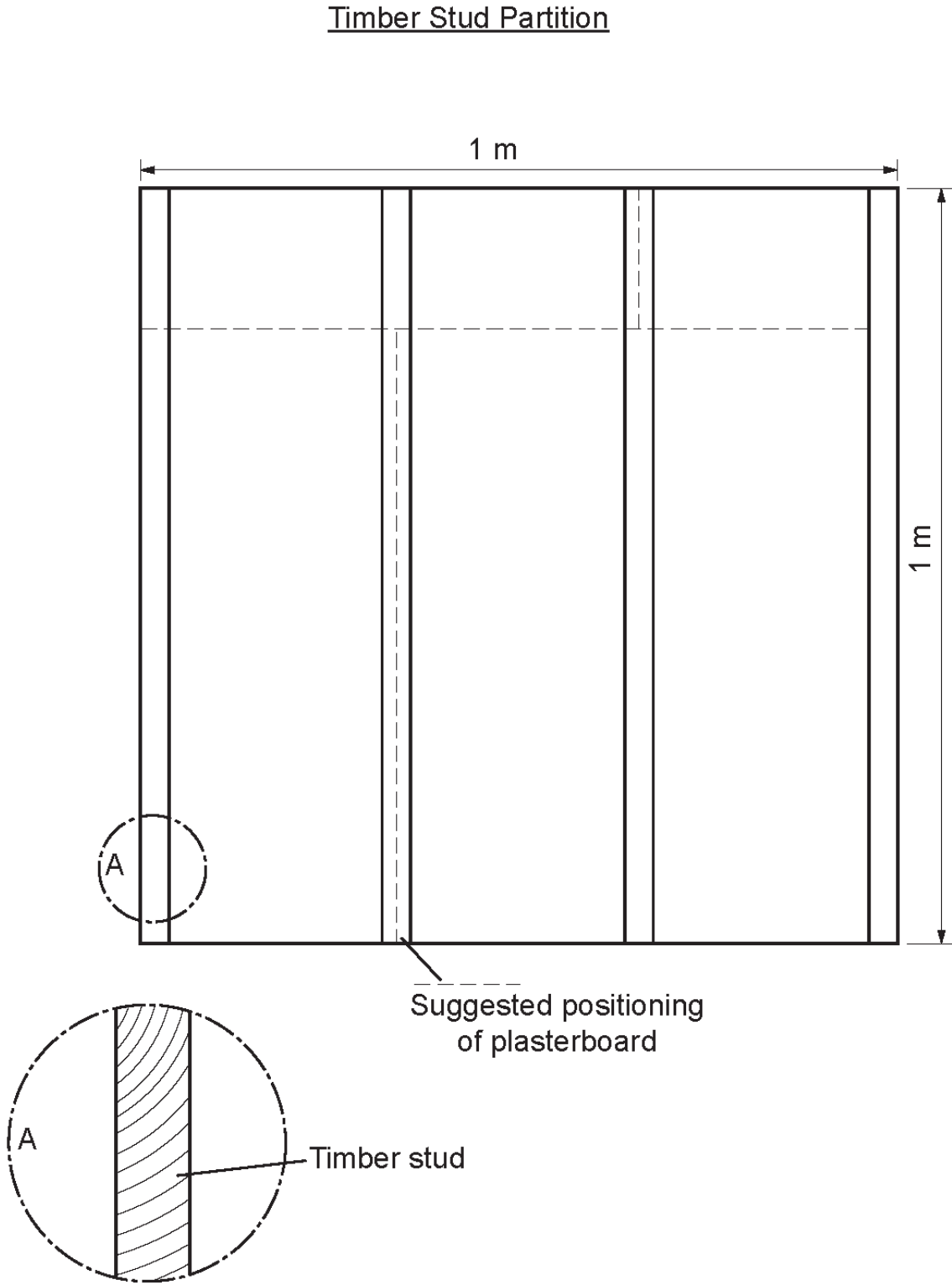

Drawings and diagrams

Unit 103 Construction Trade Occupations - Plastering

Tasks 1 & 2 Fix plasterboards & Apply plaster to vertical surfaces

Figure 2: Timber stud partition with plasterboard fixed and setting coat

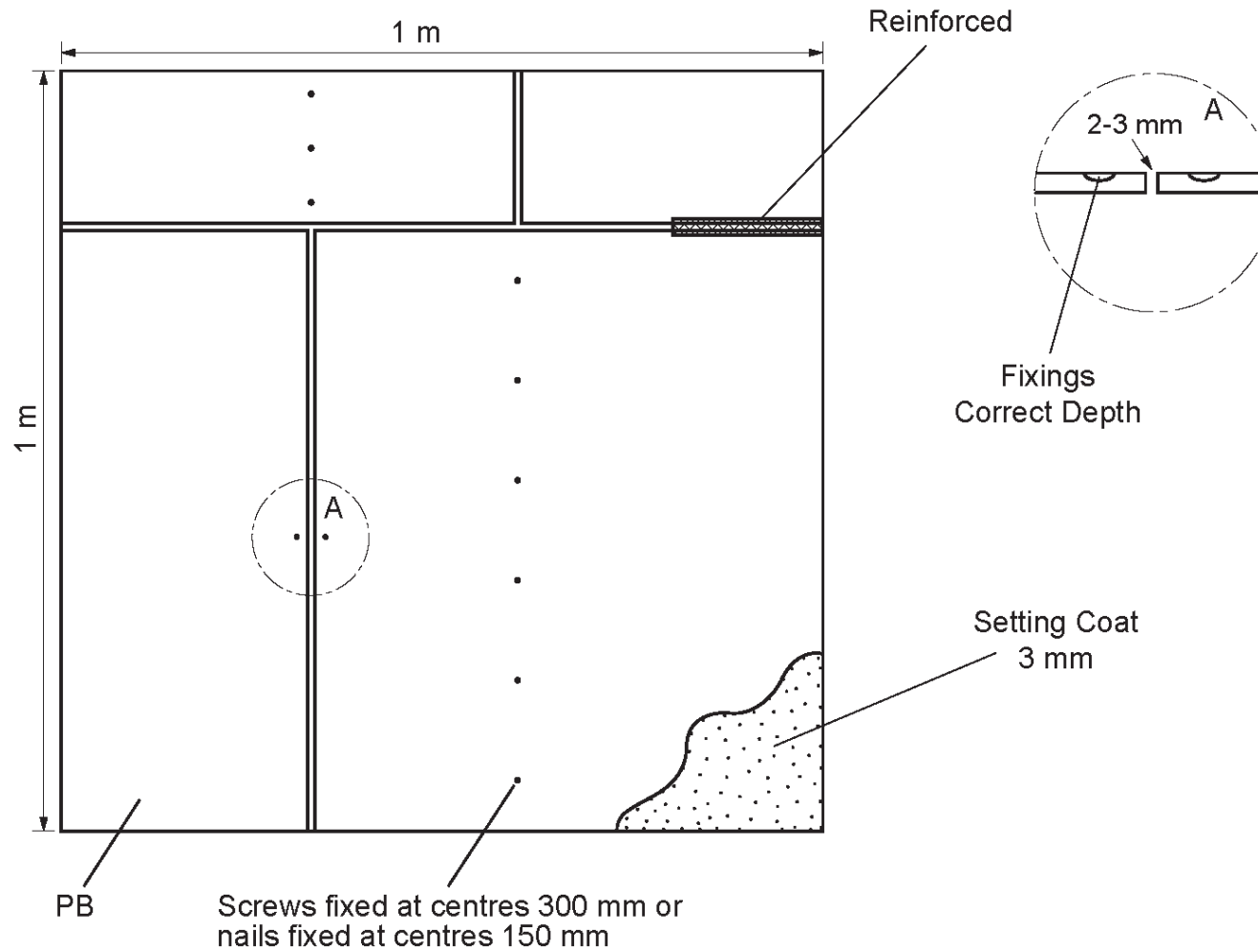

Drawings and diagrams

Unit 105 Construction Trade Occupations - Bricklaying

Task 1 Prepare, cut and lay bricks and blocks to level and line

Figure 1: Example of plan view of brickwall and blockwall

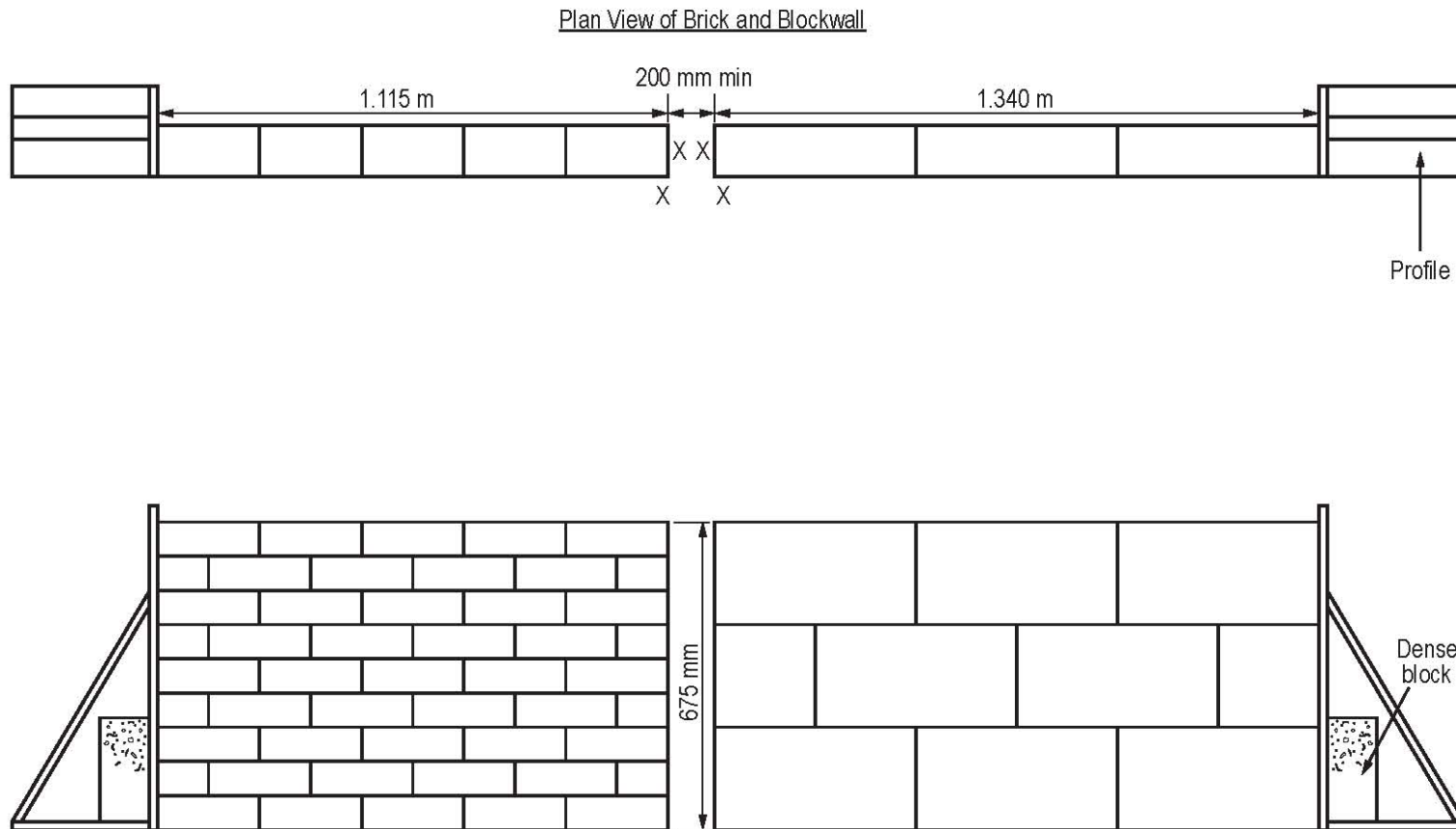

Specification:

- Bricks - 50
- Blocks - 10 Inc. 10% c/w
- Training Mortar
- Brick joint finish - Halfround
- Block joint finish - flush
- X-Plumbing points

Drawings and diagrams

Unit 106 Construction Trade Occupations - Tiling

Task 1 Apply and finish tiling to vertical surfaces and restore the work area on completion of task

Figure 1: Example of completed tiled kitchen wall area and specification

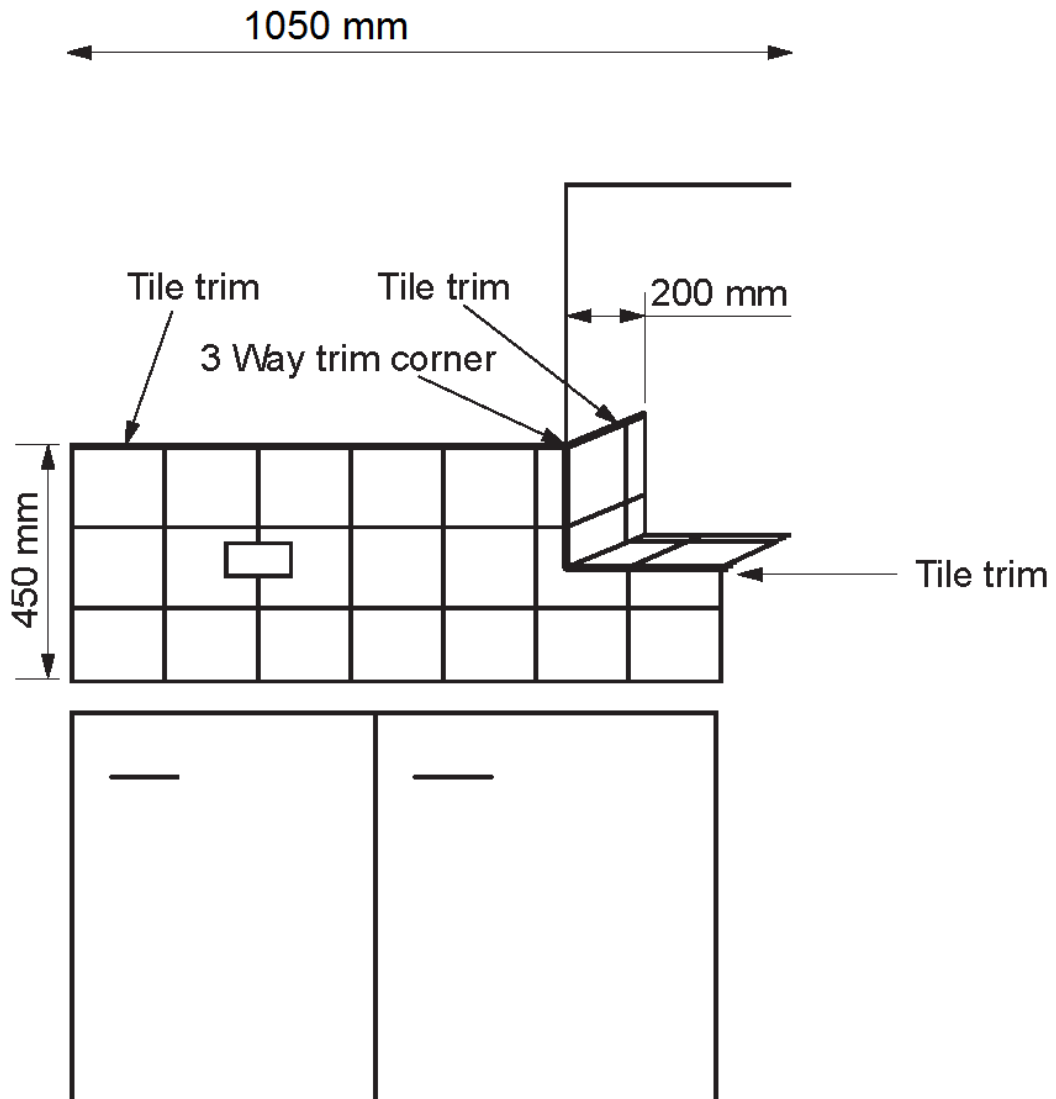

Specification

Drawing not to scale.

To include window reveal, cill and cutting around one double socket.

Cill requires 1 mm fall to allow water to run away from window.

Minimum tiled area: 1050 mm x 450 mm.

200 mm window reveal.

External angles to be finished with tile trims.

Tiles to be used: 150 mm x 150 mm.

Tile joints to be 2 mm.

Drawings and diagrams

Unit 107 Construction Trade Occupations - Carpentry

Task 1 Prepare and fix door ironmongery

Figure 1: Door with handles and lock

Diagram not to scale

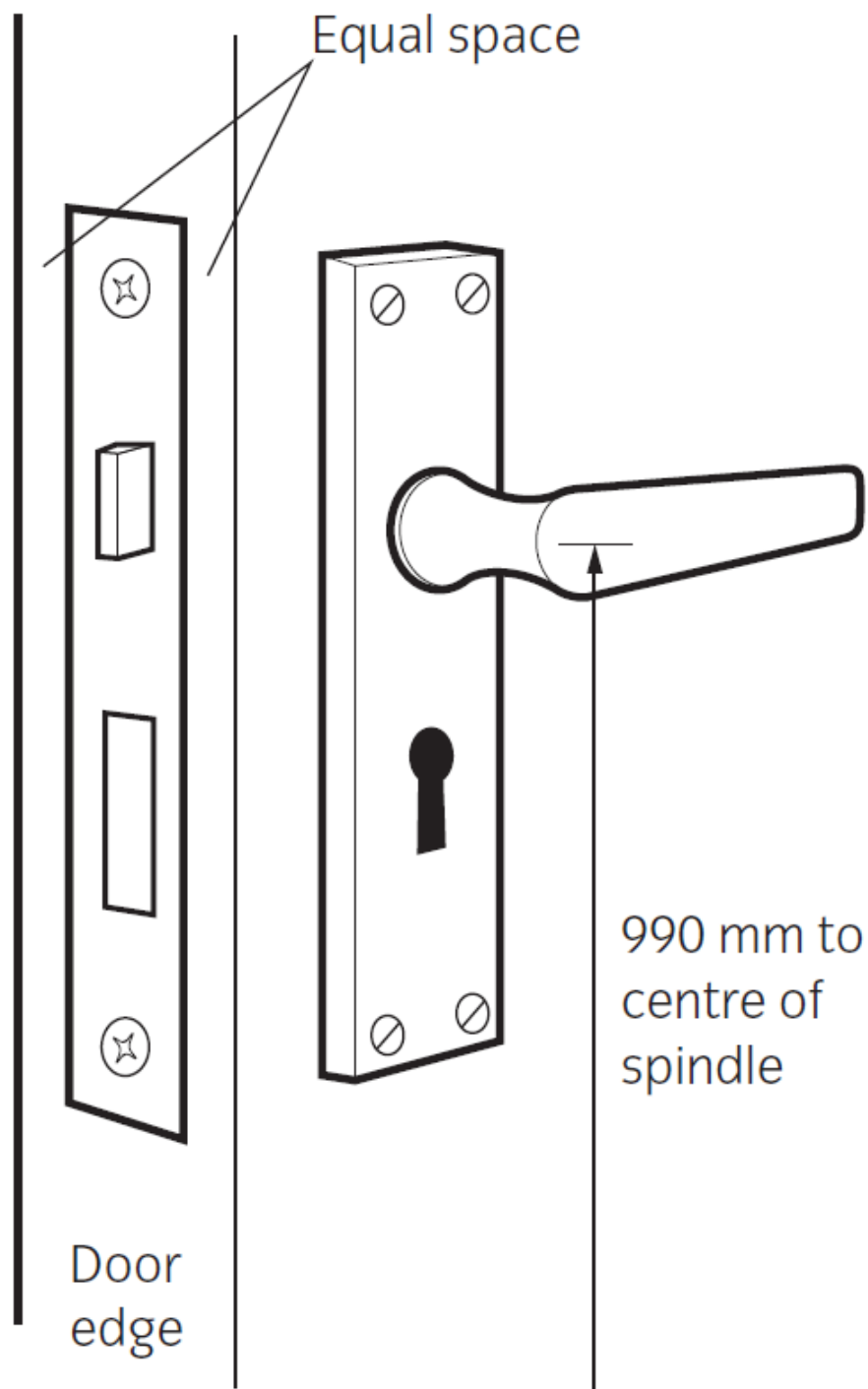

Drawings and diagrams

Unit 107 Construction Trade Occupations - Carpentry

Task 1 Prepare and fix door ironmongery

Figure 2: Door jamb with striker plate

Diagram not to scale

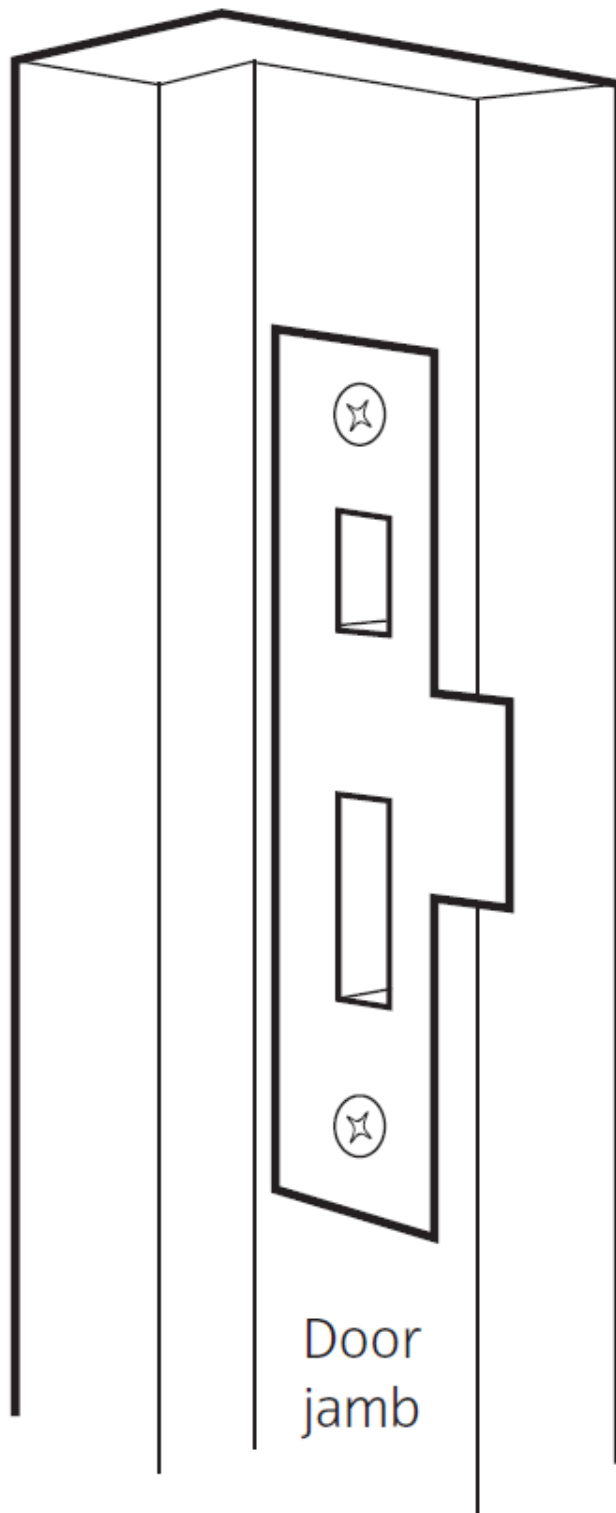

Drawings and diagrams

Unit 107 Construction Trade Occupations - Carpentry

Task 2 Prepare and fix skirting

Figure 1: Skirting board

Diagram not to scale

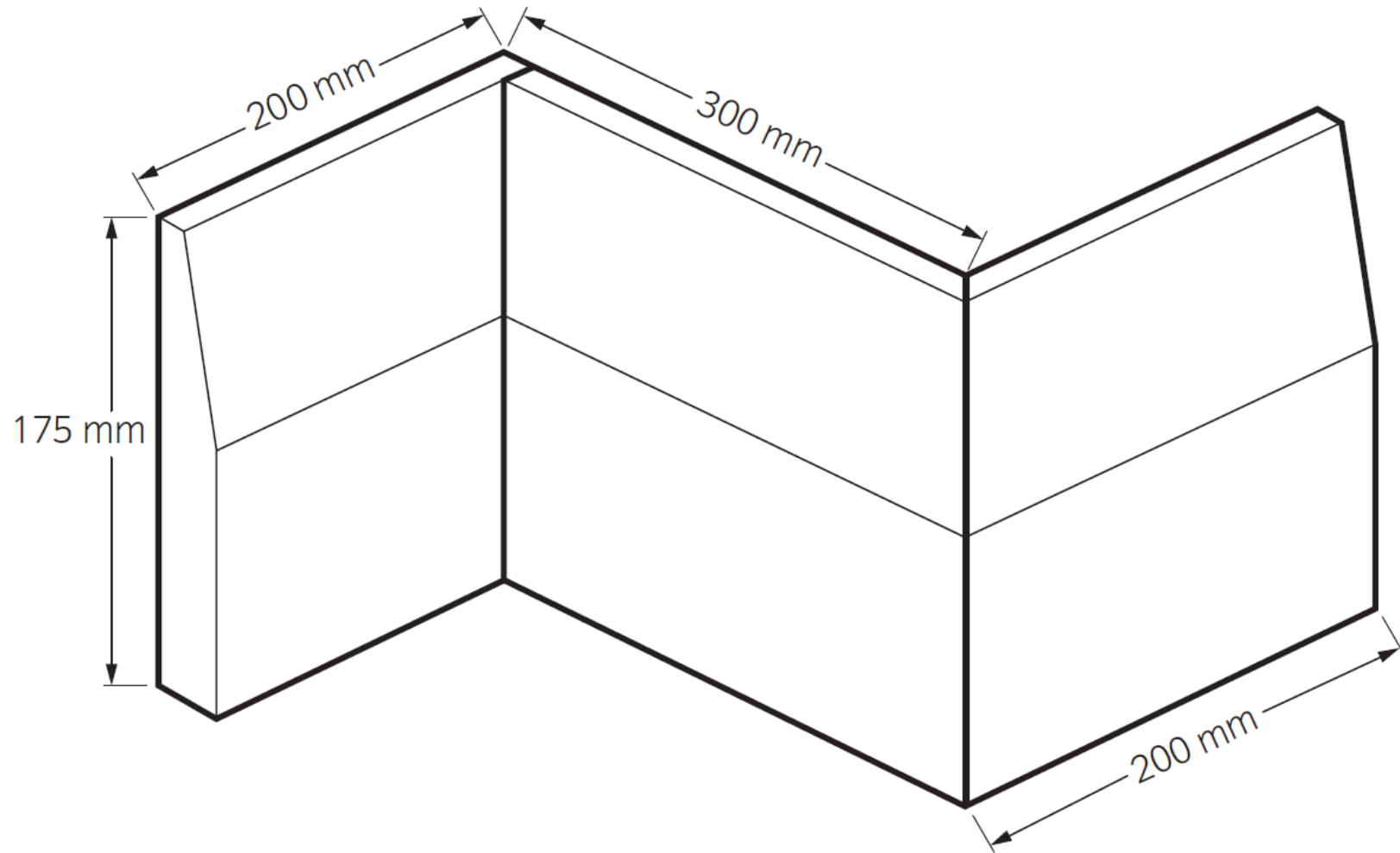

Drawings and diagrams

Unit 108 Handle and Store Construction Materials and Components

Task 1 Receive a delivery correctly

Figure 1: Delivery Note

UK Building Supplies Ltd

Delivery Note

	Order number	Order date	Delivery date	Invoice Number	
	21	15/11/13	17/11/13	24367	
QTY	Item			Unit cost (£) Including VAT	Total cost (£) Including VAT
2	3 m length of 75 mm x 50 mm timber			6.48 per m	38.88
2	25 kg bag of cement			5.00	10.00
20	bricks			0.38	7.60
5	blocks			1.70	8.50
1	5 litre tin of paint			21.00	21.00
				Total	85.98

Goods accepted in acceptable condition

Signed by _____

Additional information:

Published by City & Guilds
1 Giltspur Street
London
EC1A 9DD
www.cityandguilds.com

**City & Guilds is a registered charity
established to promote education
and training**

About City & Guilds

As the UK's leading vocational education organisation, City & Guilds is leading the talent revolution by inspiring people to unlock their potential and develop their skills. We offer over 500 qualifications across 28 industries through 8500 centres worldwide and award around two million certificates every year. City & Guilds is recognised and respected by employers across the world as a sign of quality and exceptional training.

City & Guilds Group

The City & Guilds Group operates from three major hubs: London (servicing Europe, the Caribbean and Americas), Johannesburg (servicing Africa), and Singapore (servicing Asia, Australia and New Zealand). The Group also includes the Institute of Leadership & Management (management and leadership qualifications), City & Guilds Land Based Services (land-based qualifications), the Centre for Skills Development (CSD works to improve the policy and practice of vocational education and training worldwide) and Learning Assistant (an online e-portfolio).

Copyright

The content of this document is, unless otherwise indicated, © The City and Guilds of London Institute and may not be copied, reproduced or distributed without prior written consent. However, approved City & Guilds centres and candidates studying for City & Guilds qualifications may photocopy this document free of charge and/or include a PDF version of it on centre intranets on the following conditions:

- centre staff may copy the material only for the purpose of teaching candidates working towards a City & Guilds qualification, or for internal administration purposes
- candidates may copy the material only for their own use when working towards a City & Guilds qualification

The *Standard Copying Conditions* (see the City & Guilds website) also apply.

Published by City & Guilds, a registered charity established to promote education and training

Every effort has been made to ensure that the information contained in this publication is true and correct at the time of going to press. However, City & Guilds' products and services are subject to continuous development and improvement and the right is reserved to change products and services from time to time. City & Guilds cannot accept liability for loss or damage arising from the use of information in this publication.