

6806-26 Diploma in Bench Joinery at SCQF Level 5

September 2014 Version 1.1

PRACTICAL TASK MANUAL

Contents

Task manual amendments	1
Candidate details	2
Unit assessment overview	3
Practical task completion record	3
Instructions to candidates	5
Unit 211 Set up and operate a circular saw	6
Task 1 Change circular saw blades and cut timber and manufactured boards	6
Unit 212 Produce setting out details for bench joinery products	8
Task 1 Interpret information and set out for a half glazed door	8
Unit 213 Mark out from setting out details for bench joinery products	10
Task 1 Mark out a half glazed door	10
Task 2 Mark out a staircase	11
Unit 214 Manufacture bench joinery products	13
Task 1 Manufacture and assemble a half glazed door	13
Task 2 Manufacture and assemble a staircase	15
Drawings and diagrams	17
Unit 211 Set up and operate a circular saw	17
Unit 212 Produce setting out details for bench joinery products	21
Unit 213 Mark out from setting out details for bench joinery products	21
Unit 214 Manufacture bench joinery products	21

Task manual amendments

Amendments since version 1.0

Page 8	Unit 212, Task 1 task instructions amended.
Page 10	Unit 213, Task 1 observation checklist amended.
Pages 11 and 12	Unit 213, Task 2 observation checklist amended.
Pages 13 and 14	Unit 214, Task 1 task time, observation checklist and grading rules amended.
Page 15 and 16	Unit 214, Task 2 task time and observation checklist amended.
Page 21	Units 212, 213 and 214, Task 1 Figure 1 Door elevation and height section drawing amended.
Page 22	Units 212, 213 and 214, Task 1 Figure 2 Middle rail section drawing amended.
Page 23	Units 212, 213 and 214, Task 1 Figure 3 Middle rail joint detail drawing amended.
Page 24	Units 213 and 214, Task 2 Figure 1 Staircase drawing amended.
Page 25	Units 213 and 214, Task 2 Figure 2 Staircase construction detail drawing amended.
Page 26	Units 213 and 214, Task 2 Figure 3 String to newel joint drawing amended.
Page 27	Units 213 and 214, Task 2 Figure 4 Bare faced tenon detail drawing amended.

Candidate details



This *Practical task manual* is a record of your achievement in practical assessments. You must keep it in good condition and it must be stored in a safe place by your Assessor.

Please fill in all of your details before you carry out any assessments.

Candidate Details

Surname		Forename(s)	
---------	--	-------------	--

City & Guilds enrolment number	
--------------------------------	--

Centre Details

Name		Centre No	
------	--	-----------	--

I understand the requirements of the qualification and that all the work towards the assessments must be my own.

Candidate signature (please print)	
--	--

Assessor name (please print)		Signed	
--	--	--------	--

Date	
------	--

Unit assessment overview

Practical task completion record

To be completed by Assessor:

For each task, the points for each grade are
 Pass = 1, Merit = 2, and Distinction = 3 points.

Conversion chart	
Average	Overall Grade
1 – 1.5	Pass
1.6 – 2.5	Merit
2.6 – 3	Distinction

†All tasks must be passed for the unit to be achieved.

Unit 211 Set up and operate a circular saw

Task	Grade for task
1 Change circular saw blades and cut timber and manufactured boards	P / X
End of unit knowledge test	P / X

Assessor signature and date:

Candidates must pass all tasks, and the end of unit knowledge test, for this unit to achieve a pass grade overall.

Overall grade

Unit 212 Produce setting out details for bench joinery products

Task	Grade for task
1 Interpret information and set out for a half glazed door	P / M / D / X
End of unit knowledge test	P / X

Assessor signature and date:

The overall grade will be the same as the single graded task in this unit.

Overall grade

Unit 213 Mark out from setting out details for bench joinery products

Task	Grade for task
1 Mark out a half glazed door	P / X
2 Mark out a staircase	P / X
End of unit knowledge test	P / X

Assessor signature and date:

Candidates must pass all tasks, and the end of unit knowledge test, for this unit to achieve a pass grade overall.

Overall grade

Unit 214 Manufacture bench joinery products

Task	Grade for task
1 Manufacture and assemble a half glazed door	P / M / D / X
2 Manufacture and assemble a staircase	P / X
End of unit knowledge test	P / X

Assessor signature and date:

The overall grade will be the same as the single graded task in this unit.

Overall grade

Authenticity and IQA/QC sampling

The assessor's signature on individual tasks will be taken as assurance that the judgements recorded are made on authentic candidate work produced under appropriate conditions. Please complete the declaration below to confirm this is the case.

I confirm that all tasks were conducted under conditions designed to assure the authenticity of the candidate's work, and am satisfied that, to the best of my knowledge, the work assessed was solely that of the candidate.
I have judged all assessments against the relevant assessment and grading criteria and award the candidate the unit grades as calculated above.

Assessor signature	Date
*IQA signature and date	*QC signature and date

*IQA and QC signatures attest to the evidence available on the recorded date(s).

Instructions to candidates

About this document

This *Practical task manual* contains all of the practical assessment for the 6806-26 SCQF Level 5 Diploma in Bench Joinery.

Practical tasks

These tasks let you show your practical skills and are usually graded pass, merit or distinction – a few are pass only. These tasks will be assessed by your assessor watching how you carry out the tasks and checking your final pieces of work.

Before you carry out the task you will be told how it will be assessed and you should read the observation checklist at the end of each task so you know what you need to do to get each grade.

You can ask your assessor for help in understanding the task instructions, but all of the work must be your own.

Health and safety

You must use safe working practices at all times.

You are responsible for your own safety and the safety of others. If you behave in an unsafe way, you will be stopped and given a warning. If you do not meet all of the Health and Safety requirements, the assessment will be stopped. Your assessor will not be able to let you try the task again until they are sure you can work safely.

Time considerations

Each task shows how long it is likely to take. This is for guidance and so you can plan your work. If you have a good reason for needing more time you must explain this to your assessor as soon as possible so they can decide whether you can have more time.

Security

Where an assignment is taken over more than one session, all documentation, paperwork and work products must be labelled carefully with your name and kept securely at the centre. Your assessor will give you directions about how to leave your work.

Opportunities to repeat tasks

The tasks are 'end tests' so you will only be asked to take the assessment when you have had the chance to do all of the learning and practice you need. You will be able to try the whole task again if you do not pass, but you will not be able to take the assessment again just to try to get a better grade.

Feedback

As well as telling you the result for the task your assessor will give you feedback. They will give you a feedback sheet with details of what you could do to improve, and also what you did well in. This will help you to prepare for other assessments or to retake the assessment if you need to.

Unit 211 Set up and operate a circular saw

Task 1 Change circular saw blades and cut timber and manufactured boards

Expected time	3 hours
Task instructions	<ul style="list-style-type: none"> • Complete a risk assessment • Change the blade on a circular saw. • Set up a circular saw ready for use. • Rip a section of timber with a circular saw as shown in Figures 1 and 2. • Cut board material as shown in Figure 4
Diagrams	Figure 1 Rip cuts page 17 Figure 2 Rip cuts measurement detail page 18 Figure 3 45° rip cut saddle 19 Figure 4 Tapered cut page 20

Observation checklist

AC	The candidate has	Pass	Merit	Distinction
3.1 6.1	completed the risk assessment form accurately, to meet current health and safety legislation	<input type="checkbox"/>		
3.2 3.3 3.4 6.2	followed the sequence for changing circular saw blades using manufacturers' tools in accordance with their instructions and current legislation <ul style="list-style-type: none"> • isolated machine before proceeding 	<input type="checkbox"/>		
	<ul style="list-style-type: none"> • removed guarding, riving knife and saw blade safely and without damage 	<input type="checkbox"/>		
	<ul style="list-style-type: none"> • cleaned machine down 	<input type="checkbox"/>		
	<ul style="list-style-type: none"> • checked replacement blade prior to fitting for correct type and sharpness 	<input type="checkbox"/>		
	<ul style="list-style-type: none"> • saw blade seating and cutting direction correct 	<input type="checkbox"/>		
	<ul style="list-style-type: none"> • tightened blade in accordance with manufacturer's instructions 	<input type="checkbox"/>		
	<ul style="list-style-type: none"> • set riving knife as per current legislation (ACoP) 	<input type="checkbox"/>		
	<ul style="list-style-type: none"> • replaced guarding/ancillary components 	<input type="checkbox"/>		
	<ul style="list-style-type: none"> • checked blade for free rotation 	<input type="checkbox"/>		
	<ul style="list-style-type: none"> • checked machine for faults before reconnecting machine 	<input type="checkbox"/>		
6.4	set guards according to current legislation (ACoP)	<input type="checkbox"/>		

AC	The candidate has	Pass	Merit	Distinction
6.3 6.5 6.6 6.7	identified timber defects <ul style="list-style-type: none"> timber appropriately fed in relation to any cupping, bowing or dead knots 	<input type="checkbox"/>		
	set fences, adjust saw blades and cut material in accordance with Figures 1-4 timber cut as in Figures 1 and 2 <ul style="list-style-type: none"> sections A and B dimensioned within 1 mm in accordance with Figure 2 	<input type="checkbox"/>		
	<ul style="list-style-type: none"> square timber for sections C and D brought to 45 mm wide within 1 mm 	<input type="checkbox"/>		
	<ul style="list-style-type: none"> sections C and D dimensioned in within 1 mm using saddle, in accordance with Figure 2 	<input type="checkbox"/>		
	<ul style="list-style-type: none"> ensured wedge jig handle is sufficiently long to keep hands at least 300 mm away from blade 	<input type="checkbox"/>		
	<ul style="list-style-type: none"> tapered cut to dimensions within 1 mm in accordance with Figure 4 	<input type="checkbox"/>		
6.8 6.9	followed current environmental and relevant health and safety legislation relating to changing circular saw blades and cutting of timber and manufactured boards. This includes: <ul style="list-style-type: none"> push stick used where required the use of appropriate PPE at all times appropriate extraction used at all times cleaning down of all machines after use 	<input type="checkbox"/>		

Task grading rules		Task grade:
To award a pass : every activity in the checklist must be successfully achieved.		
Assessor	Signature & Date	

Unit 212 Produce setting out details for bench joinery products

Task 1 Interpret information and set out for a half glazed door

Expected time	4 hours
Task instructions	<ul style="list-style-type: none"> • Compare the job specification with Figures 1-3 (half glazed door diagrams). • Identify and report discrepancies and errors by circling each error. Write down the correct information in the spaces provided on the job specification. Hand the corrected specification to the assessor for marking before continuing. • Complete a risk assessment. • Complete a tool list. • Set out height and width rod for a half glazed door. • Complete a cutting list and requisition sheet for ironmongery. • Work according to environmental and health and safety regulations.
Diagrams	Figure 1 Door elevation and height section page 21 Figure 2 Middle rail section page 22 Figure 3 Middle rail joint detail page 23

Observation checklist

AC	The candidate has	Pass	Merit	Distinction
2.1 2.2 2.3	checked information is accurate and discrepancies recorded	<input type="checkbox"/> Four discrepancies /errors identified	<input type="checkbox"/> Five discrepancies /errors identified	<input type="checkbox"/> Six discrepancies/ errors identified
5.1	completed the risk assessment form accurately, to meet current health and safety legislation	<input type="checkbox"/>		
5.2	completed a resource checklist and used the correct tools to set out half glazed door <ul style="list-style-type: none"> • overall height correct within 1 mm (not undersized) 	<input type="checkbox"/>		
	<ul style="list-style-type: none"> • overall width correct within 1 mm (not undersized) 	<input type="checkbox"/>		
	<ul style="list-style-type: none"> • mid rail position correct 	<input type="checkbox"/> ± 3 mm	<input type="checkbox"/> ± 2 mm	<input type="checkbox"/> ± 1 mm
	<ul style="list-style-type: none"> • all section sizes correct to within 1 mm 	<input type="checkbox"/>		
	<ul style="list-style-type: none"> • all section profiles correct to within 1 mm 	<input type="checkbox"/>		
	<ul style="list-style-type: none"> • joint proportions and positions shown correctly 	<input type="checkbox"/>		

AC	The candidate has	Pass	Merit	Distinction
5.3	correctly completed a cutting list	<input type="checkbox"/>		
5.4	correctly completed a requisition sheet for ironmongery	<input type="checkbox"/>		
5.5	followed current environmental and relevant health and safety regulations relating to setting out a half glazed door	<input type="checkbox"/>		

Task grading rules		Task grade:
To award a pass : every activity in the checklist must be successfully achieved.		
To award a merit : in addition to the above, both (2) graded activities in the checklist must be achieved to at least a merit standard.		
To award a distinction : in addition to both of the above, both (2) graded activities in the checklist must be achieved to a distinction standard.		
Assessor	Signature & Date	

Unit 213 Mark out from setting out details for bench joinery products

Task 1 Mark out a half glazed door

Expected time	2 hours
Task instructions	<ul style="list-style-type: none"> • Complete a risk assessment. • Complete a tool list. • Mark out component parts from setting out details. • Work according to environmental and health and safety regulations.
Diagrams	Figure 1 Door elevation and height section page 21 Figure 2 Middle rail section page 22 Figure 3 Middle rail joint detail page 23

Observation checklist

AC	The candidate has	Pass	Merit	Distinction
3.1	completed the risk assessment form accurately, to meet current health and safety legislation	<input type="checkbox"/>		
3.2	completed a resource checklist and selected the correct tools required for marking out	<input type="checkbox"/>		
3.3	correctly selected <ul style="list-style-type: none"> • face side • face edge 	<input type="checkbox"/>		
3.4	mark out components for half glazed door <ul style="list-style-type: none"> • rail positions/mortices in correct position to within 1 mm 	<input type="checkbox"/>		
	<ul style="list-style-type: none"> • mortices and tenons marked out accurately to within 1 mm 	<input type="checkbox"/>		
	<ul style="list-style-type: none"> • tenon shoulders marked out accurately to within 1 mm 	<input type="checkbox"/>		
	<ul style="list-style-type: none"> • sections correctly indicated 	<input type="checkbox"/>		
3.5	followed current environmental and relevant health and safety regulations relating to marking out for half glazed door	<input type="checkbox"/>		

Task grading rules		Task grade:
To award a pass : every activity in the checklist must be successfully achieved.		
Assessor	Signature & Date	

Unit 213 Mark out from setting out details for bench joinery products

Task 2 Mark out a staircase

Expected time	3 hours
Task instructions	<ul style="list-style-type: none"> • Complete a risk assessment. • Complete a tool list. • Mark out component parts of a staircase. • Work according to environmental and health and safety regulations.
Diagrams	Figure 1 Staircase page 24 Figure 2 Staircase construction details page 25 Figure 3 String to newel joint page 26 Figure 4 Bare faced tenon detail page 27

Observation checklist

AC	The candidate has	Pass	Merit	Distinction
3.1	completed the risk assessment form accurately, to meet current health and safety legislation (note: where a risk assessment has been carried out for a previous task, the same form may be added to for this criteria)	<input type="checkbox"/>		
3.2	completed a resource checklist and selected the correct tools required for marking out (note: where a checklist has been completed for a previous task, the same form may be added to for this criteria)	<input type="checkbox"/>		
3.3	correctly selected <ul style="list-style-type: none"> • face side • face edge 	<input type="checkbox"/>		
3.4	mark out components for a staircase string <ul style="list-style-type: none"> • pitch board made accurately within 0.5 mm 	<input type="checkbox"/>		
	<ul style="list-style-type: none"> • tenon accurately marked out within 1 mm 	<input type="checkbox"/>		
	<ul style="list-style-type: none"> • step housings accurately marked out within 1 mm 	<input type="checkbox"/>		
	<ul style="list-style-type: none"> • margin correct within 1 mm 	<input type="checkbox"/>		
	<ul style="list-style-type: none"> • marked as a pair 	<input type="checkbox"/>		
	newel <ul style="list-style-type: none"> • mortice accurately marked out within 1 mm 	<input type="checkbox"/>		

AC	The candidate has	Pass	Merit	Distinction
	<ul style="list-style-type: none"> housing for the tread accurately marked out within 1 mm 	<input type="checkbox"/>		
	treads <ul style="list-style-type: none"> sections accurately marked out within 1 mm 	<input type="checkbox"/>		
3.5	followed current environmental and relevant health and safety regulations relating to marking out for a staircase	<input type="checkbox"/>		

Task grading rules		Task grade:
To award a pass : every activity in the checklist must be successfully achieved.		
Assessor	Signature & Date	

Unit 214 Manufacture bench joinery products

Task 1 Manufacture and assemble a half glazed door

Expected time	16 hours
Task instructions	<ul style="list-style-type: none"> • Complete a risk assessment. • Complete a tool list. • Manufacture and assemble a half glazed door. • Clean up the door to receive a paint finish. • Work according to environmental and health and safety regulations.
Diagrams	Figure 1 Door elevation and height section page 21 Figure 2 Middle rail section page 22 Figure 3 Middle rail joint detail page 23

Observation checklist

AC	The candidate has	Pass	Merit	Distinction
3.1	completed the risk assessment form accurately, to meet current health and safety legislation	<input type="checkbox"/>		
3.2 4.2 4.6	completed a resource checklist and selected the correct hand and power tools, ensuring tools are sharp before and during use	<input type="checkbox"/>		
3.3 3.4 3.5 3.6 4.1 4.3 4.4 4.5	manufactured and assembled a half glazed door <ul style="list-style-type: none"> • tenons fit mortices with no gaps exceeding 1 mm 	<input type="checkbox"/>		
	<ul style="list-style-type: none"> • securely wedged without splitting 	<input type="checkbox"/>		
	<ul style="list-style-type: none"> • haunches tight with no gaps exceeding 1 mm 	<input type="checkbox"/>		
	<ul style="list-style-type: none"> • shoulders tight with no gaps exceeding 1 mm 	<input type="checkbox"/>		
	<ul style="list-style-type: none"> • scribes tight with no gaps exceeding 1 mm 	<input type="checkbox"/>		
	<ul style="list-style-type: none"> • inside edges cleaned up prior to assembly 	<input type="checkbox"/>		
	<ul style="list-style-type: none"> • panel tight fit to grooves within 1 mm 	<input type="checkbox"/>		
	<ul style="list-style-type: none"> • rebate size correct within 1 mm as per Figure 1 	<input type="checkbox"/>		
	<ul style="list-style-type: none"> • moulding correct within 1 mm as per Figure 1 	<input type="checkbox"/>		

AC	The candidate has	Pass	Merit	Distinction
	<ul style="list-style-type: none"> sections produced clean, without breakout and to a consistent depth within 1 mm 	<input type="checkbox"/>		
	<ul style="list-style-type: none"> overall height 1050 mm 	<input type="checkbox"/> ± 3 mm	<input type="checkbox"/> ± 2 mm	<input type="checkbox"/> ± 1 mm
	<ul style="list-style-type: none"> overall width 600 mm 	<input type="checkbox"/> ± 3 mm	<input type="checkbox"/> ± 2 mm	<input type="checkbox"/> ± 1 mm
	<ul style="list-style-type: none"> without cramp marks 	<input type="checkbox"/>		
	<ul style="list-style-type: none"> parallel within 2 mm 	<input type="checkbox"/>		
	<ul style="list-style-type: none"> middle rail position 236 mm between sight lines 	<input type="checkbox"/> ± 3 mm	<input type="checkbox"/> ± 2 mm	<input type="checkbox"/> ± 1 mm
	<ul style="list-style-type: none"> square 	<input type="checkbox"/> ± 3 mm	<input type="checkbox"/> ± 2 mm	<input type="checkbox"/> ± 1 mm
	<ul style="list-style-type: none"> out of wind within 2 mm 	<input type="checkbox"/>		
	<ul style="list-style-type: none"> joints flushed using smoothing plane, without tram lines and tearing 	<input type="checkbox"/>		
	<ul style="list-style-type: none"> finished door no less than 42 mm thick 	<input type="checkbox"/>		
	<ul style="list-style-type: none"> prepared for paint finish and arrises removed 	<input type="checkbox"/>		
3.7 4.6 4.7	<p>followed current environmental and relevant health and safety regulations relating to manufacturing, assembling and finishing a half glazed door. This includes</p> <ul style="list-style-type: none"> good house keeping use of PPE use of machines in accordance with ACoP 	<input type="checkbox"/>		

Task grading rules	Task grade:
To award a pass : every activity in the checklist must be successfully achieved.	
To award a merit : in addition to the above, all 4 graded activities in the checklist must be achieved to at least a merit standard.	
To award a distinction : in addition to both of the above, all 4 graded activities in the checklist must be achieved to a distinction standard.	
Assessor	Signature & Date

Unit 214 Manufacture bench joinery products

Task 2 Manufacture and assemble a staircase

Expected time	18 hours
Task instructions	<ul style="list-style-type: none"> • Complete a risk assessment. • Complete a tool list. • Manufacture and assemble a staircase. • Clean up the staircase to receive a paint finish. • Work according to environmental and health and safety regulations.
Diagrams	Figure 1 Staircase page 24 Figure 2 Staircase construction details page 25 Figure 3 String to newel joint page 26 Figure 4 Bare faced tenon detail page 27

Observation checklist

AC	The candidate has	Pass	Merit	Distinction
3.1	completed the risk assessment form accurately, to meet current health and safety legislation (note: where a risk assessment has been carried out for a previous task, the same form may be added to for this criteria)	<input type="checkbox"/>		
3.2 4.2 4.6	completed a resource checklist and selected the correct hand and power tools, ensuring tools are sharp before and during use (note: where a checklist has been completed for a previous task, the same form may be added to for this criteria)	<input type="checkbox"/>		
3.3 3.4 3.5 3.6 4.1 4.3 4.4 4.5	manufactured and assembled a staircase <ul style="list-style-type: none"> • strings housed out correctly without breakout 	<input type="checkbox"/>		
	<ul style="list-style-type: none"> • string tenon cut correctly, tight fitting within 1 mm and draw dowelled 	<input type="checkbox"/>		
	<ul style="list-style-type: none"> • newel morticed accurately in correct position 	<input type="checkbox"/>		
	<ul style="list-style-type: none"> • treads profiled within 1 mm as per Figures 	<input type="checkbox"/>		
	<ul style="list-style-type: none"> • bottom step housed into newel post and tight fitting within 1 mm 	<input type="checkbox"/>		
	<ul style="list-style-type: none"> • treads and risers fitted correctly and tight with no gaps exceeding 1 mm 	<input type="checkbox"/>		

AC	The candidate has	Pass	Merit	Distinction
	<ul style="list-style-type: none"> wedges inserted and tight fitting throughout whole length of housing 	<input type="checkbox"/>		
	<ul style="list-style-type: none"> glue blocks securely in place 	<input type="checkbox"/>		
	<ul style="list-style-type: none"> risers secured to treads using screws without splitting 	<input type="checkbox"/>		
	<ul style="list-style-type: none"> staircase width 300 mm within 2 mm 	<input type="checkbox"/>		
	<ul style="list-style-type: none"> step rise correct within 1 mm as per Figures 	<input type="checkbox"/>		
	<ul style="list-style-type: none"> step going correct within 1 mm as per Figures 	<input type="checkbox"/>		
	<ul style="list-style-type: none"> all inside faces cleaned up prior to assembly 	<input type="checkbox"/>		
	<ul style="list-style-type: none"> completed job cleaned up, without cramp marks, arrises removed and ready for painted finish 	<input type="checkbox"/>		
3.7 4.6 4.7	<p>followed current environmental and relevant health and safety regulations relating to manufacturing, assembling and finishing a staircase. This includes</p> <ul style="list-style-type: none"> good house keeping use of PPE use of machines in accordance with ACoP 	<input type="checkbox"/>		

Task grading rules		Task grade:
To award a pass : every activity in the checklist must be successfully achieved.		
Assessor	Signature & Date	

Drawings and diagrams

Unit 211 Set up and operate a circular saw

Task 1 Change circular saw blades and cut timber and manufactured boards

Figure 1 Rip cuts

Diagram not to scale

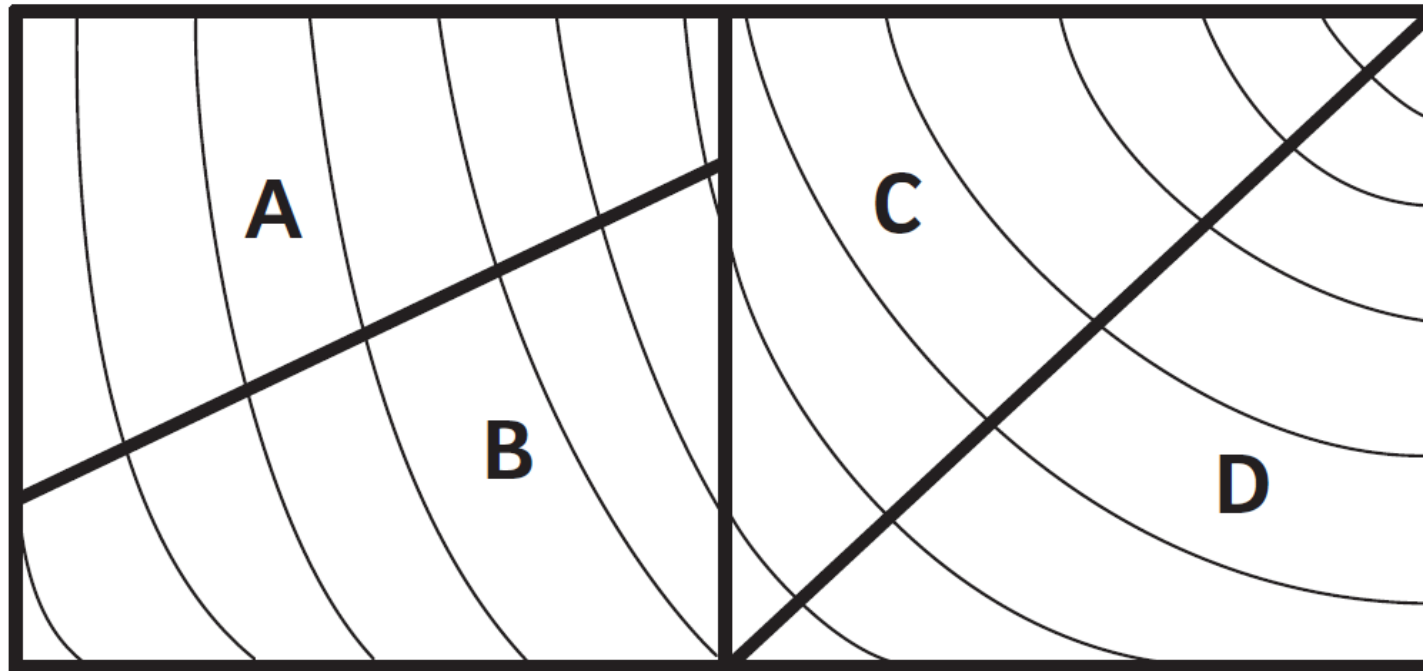

Drawings and diagrams

Unit 211 Set up and operate a circular saw

Task 1 Change circular saw blades and cut timber and manufactured boards

Figure 2 Rip cuts measurement detail

Diagram not to scale

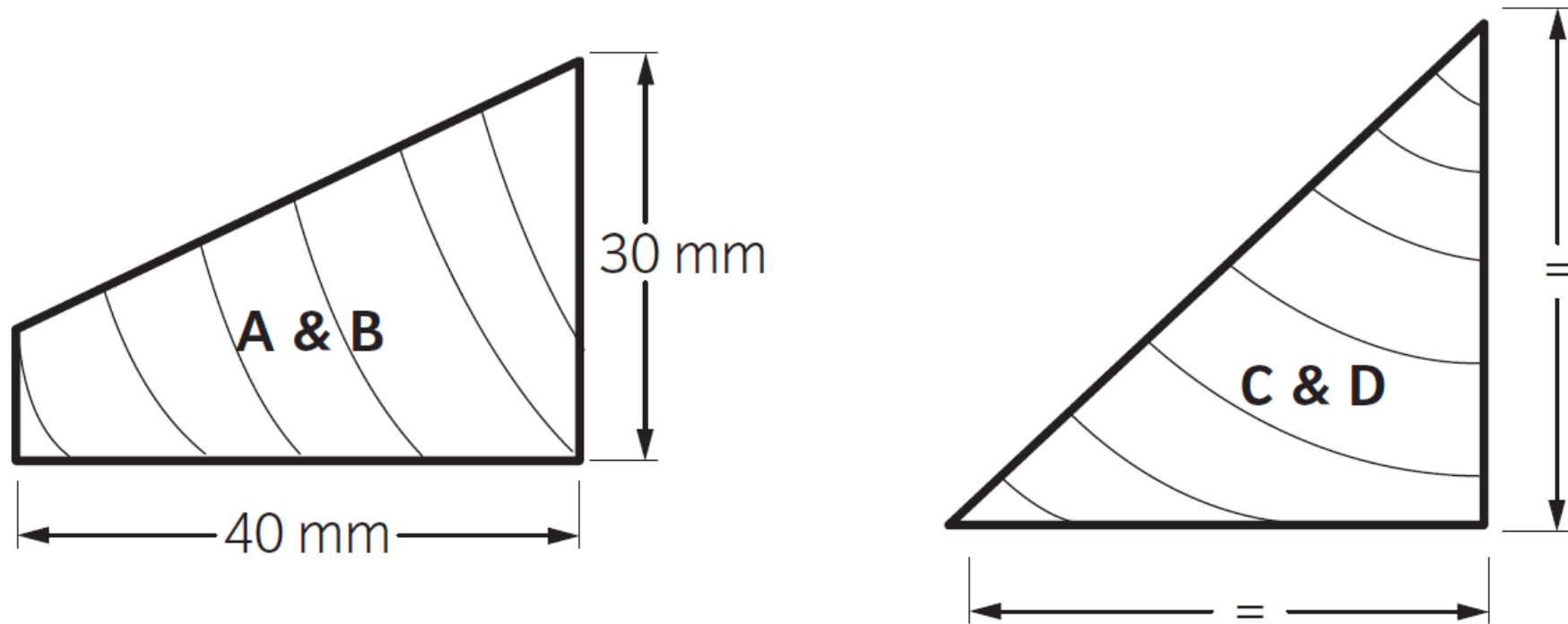

Drawings and diagrams

Unit 211 Set up and operate a circular saw

Task 1 Change circular saw blades and cut timber and manufactured boards

Figure 3 45° rip cut saddle

Diagram not to scale

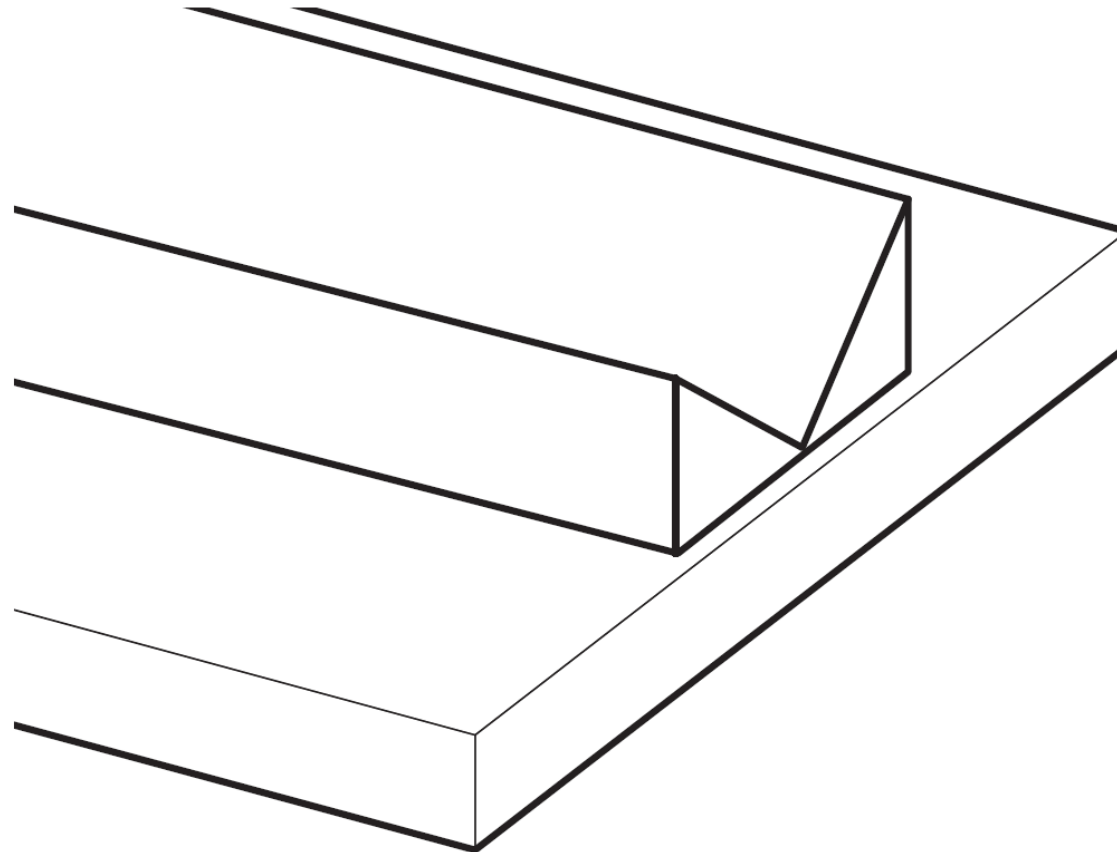

Drawings and diagrams

Unit 211 Set up and operate a circular saw

Task 1 Change circular saw blades and cut timber and manufactured boards

Figure 4 Tapered cut

Diagram not to scale

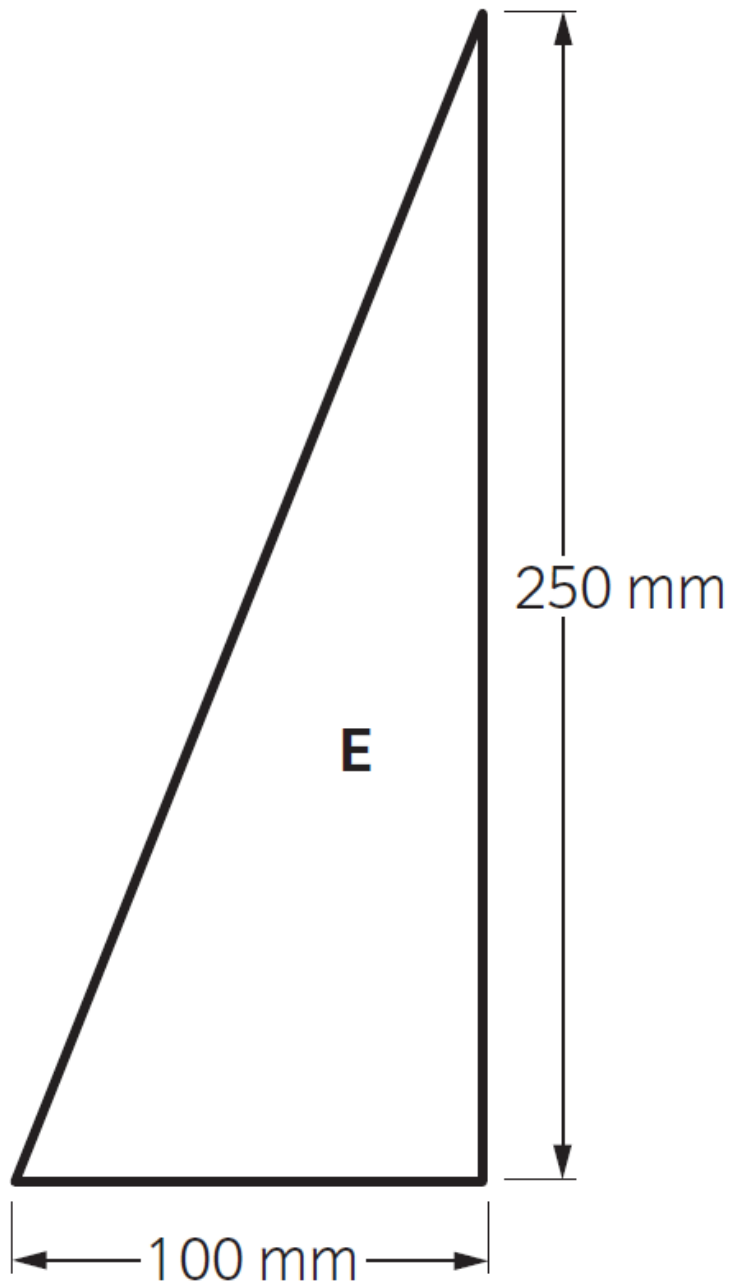

Drawings and diagrams

Unit 212 Produce setting out details for bench joinery products

Task 1 Interpret information and set out for a half glazed door

Unit 213 Mark out from setting out details for bench joinery products

Task 1 Mark out a half glazed door

Unit 214 Manufacture bench joinery products

Task 1 Manufacture and assemble a half glazed door

Figure 1: Door elevation and height section

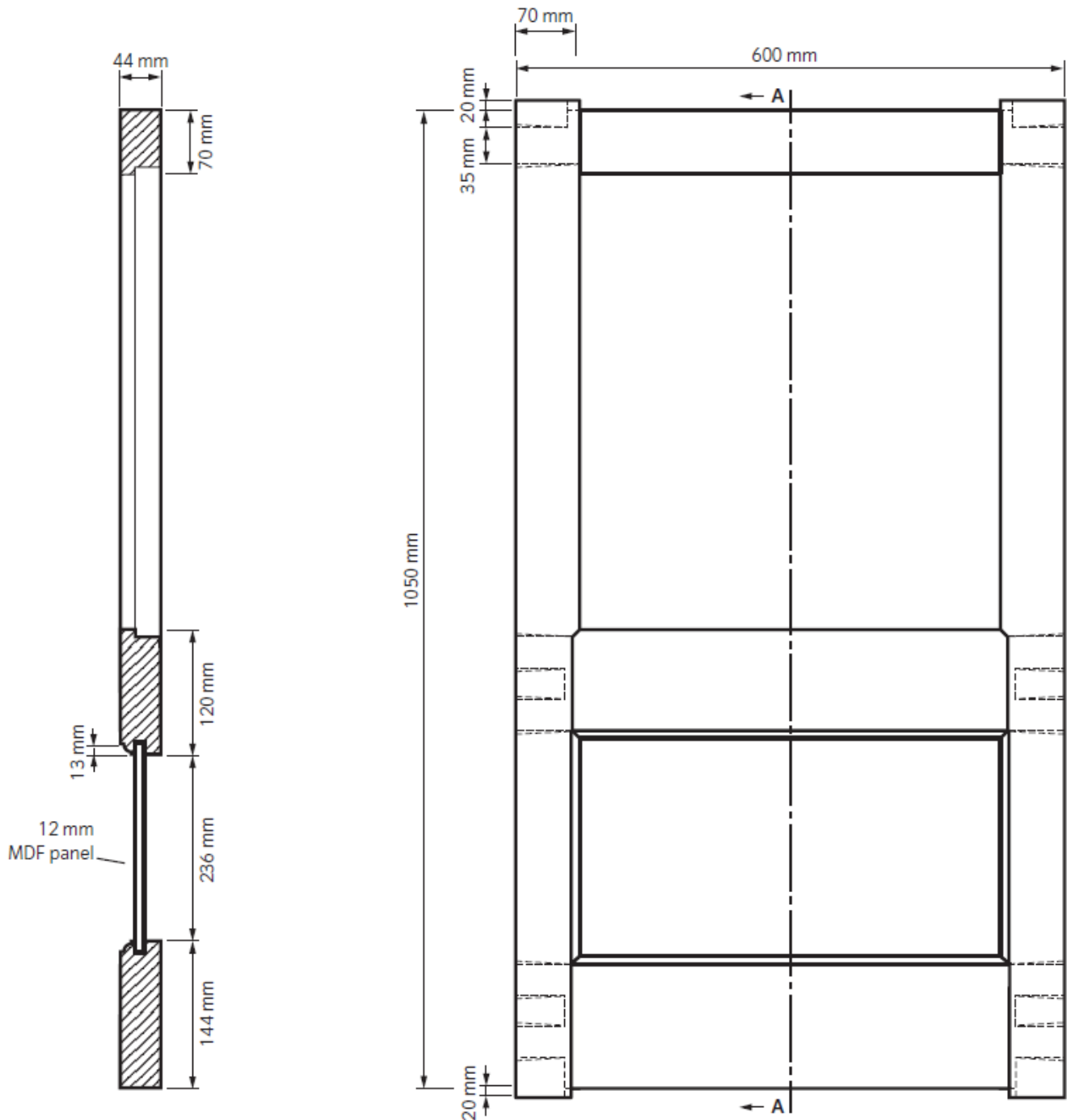

Drawings and diagrams

Unit 212 Produce setting out details for bench joinery products

Task 1 Interpret information and set out for a half glazed door

Unit 213 Mark out from setting out details for bench joinery products

Task 1 Mark out a half glazed door

Unit 214 Manufacture bench joinery products

Task 1 Manufacture and assemble a half glazed door

Figure 2: Middle rail section

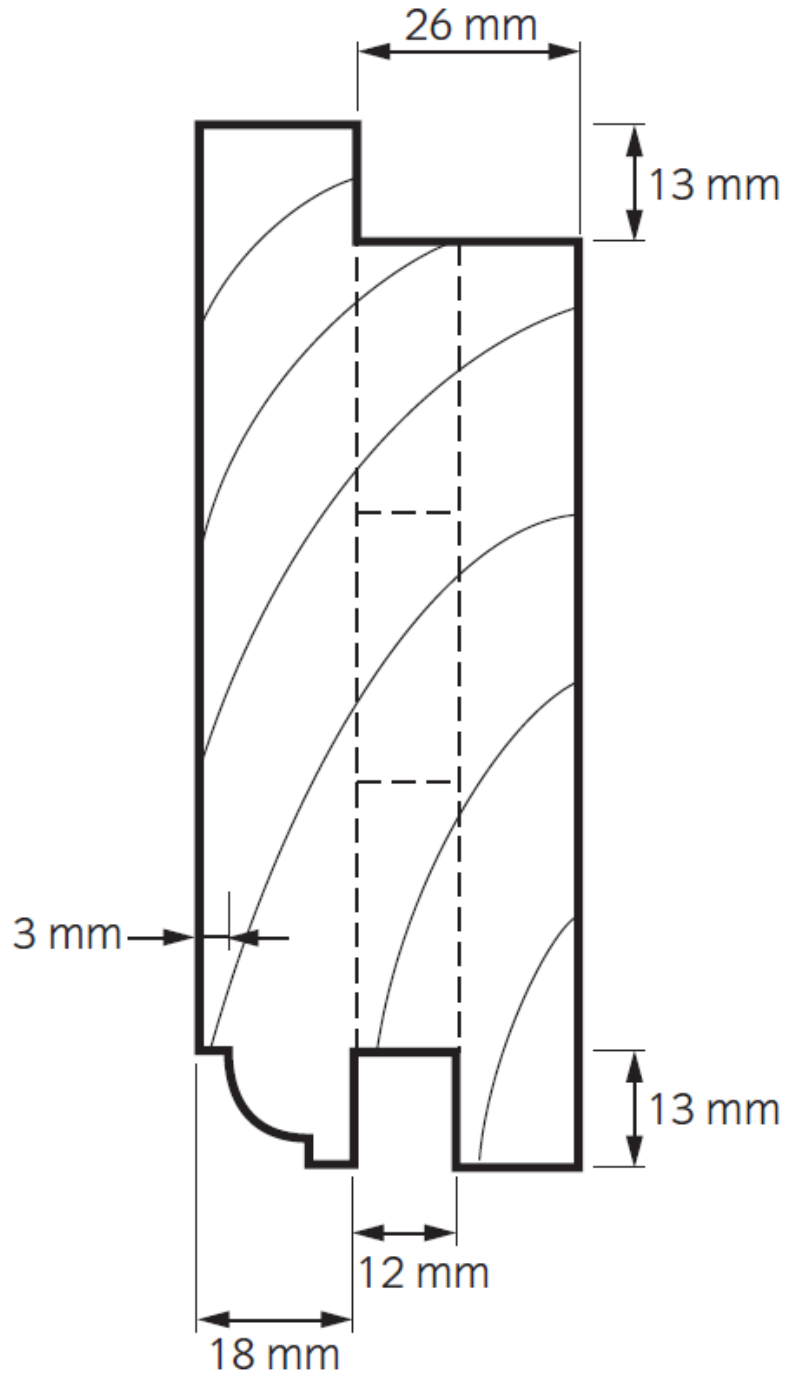

Drawings and diagrams

Unit 212 Produce setting out details for bench joinery products

Task 1 Interpret information and set out for a half glazed door

Unit 213 Mark out from setting out details for bench joinery products

Task 1 Mark out a half glazed door

Unit 214 Manufacture bench joinery products

Task 1 Manufacture and assemble a half glazed door

Figure 3: Middle rail joint detail

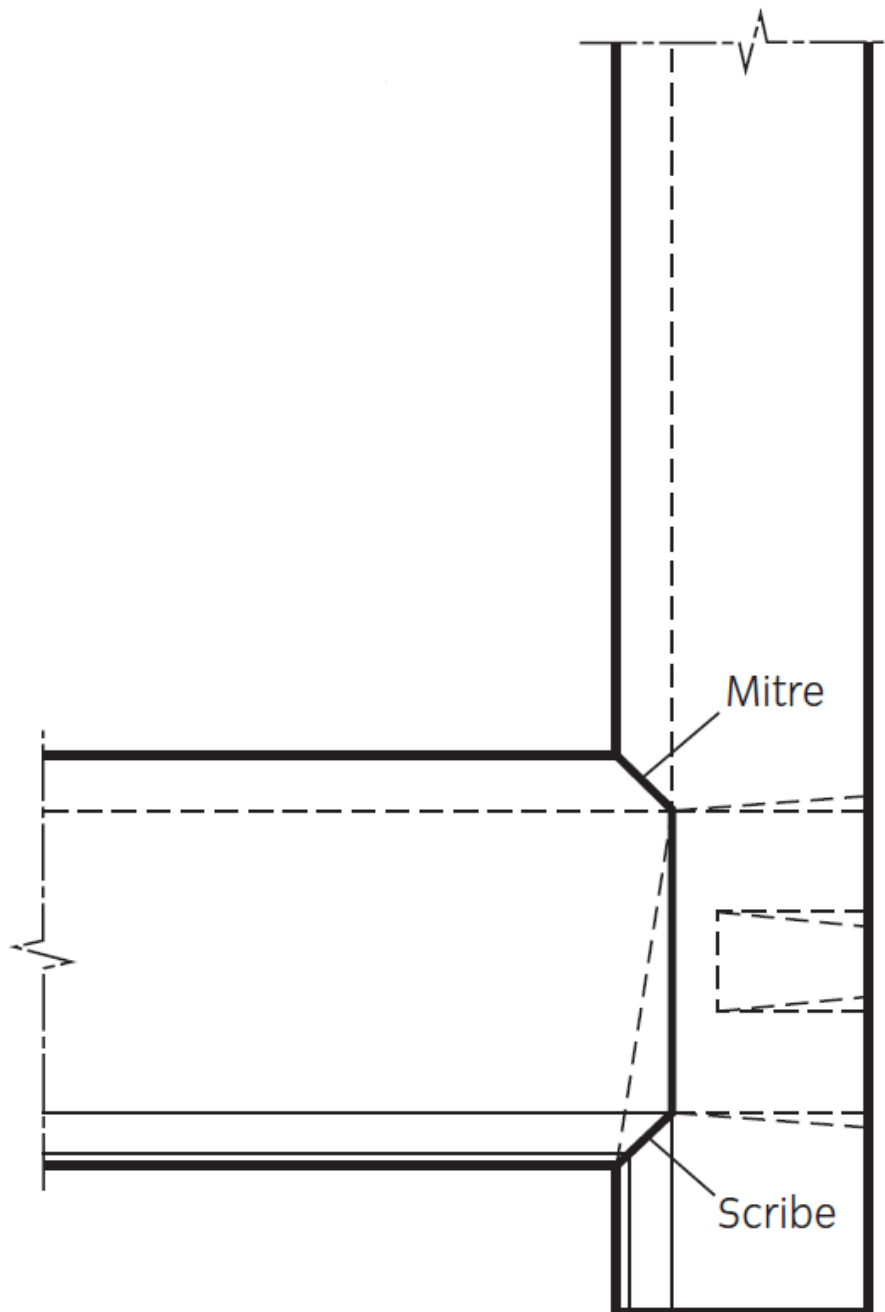

Drawings and diagrams

Unit 213 Mark out from setting out details for bench joinery products

Task 2 Mark out a staircase

Unit 214 Manufacture bench joinery products

Task 2 Manufacture and assemble a staircase

Figure 1: Staircase

Diagram not to scale

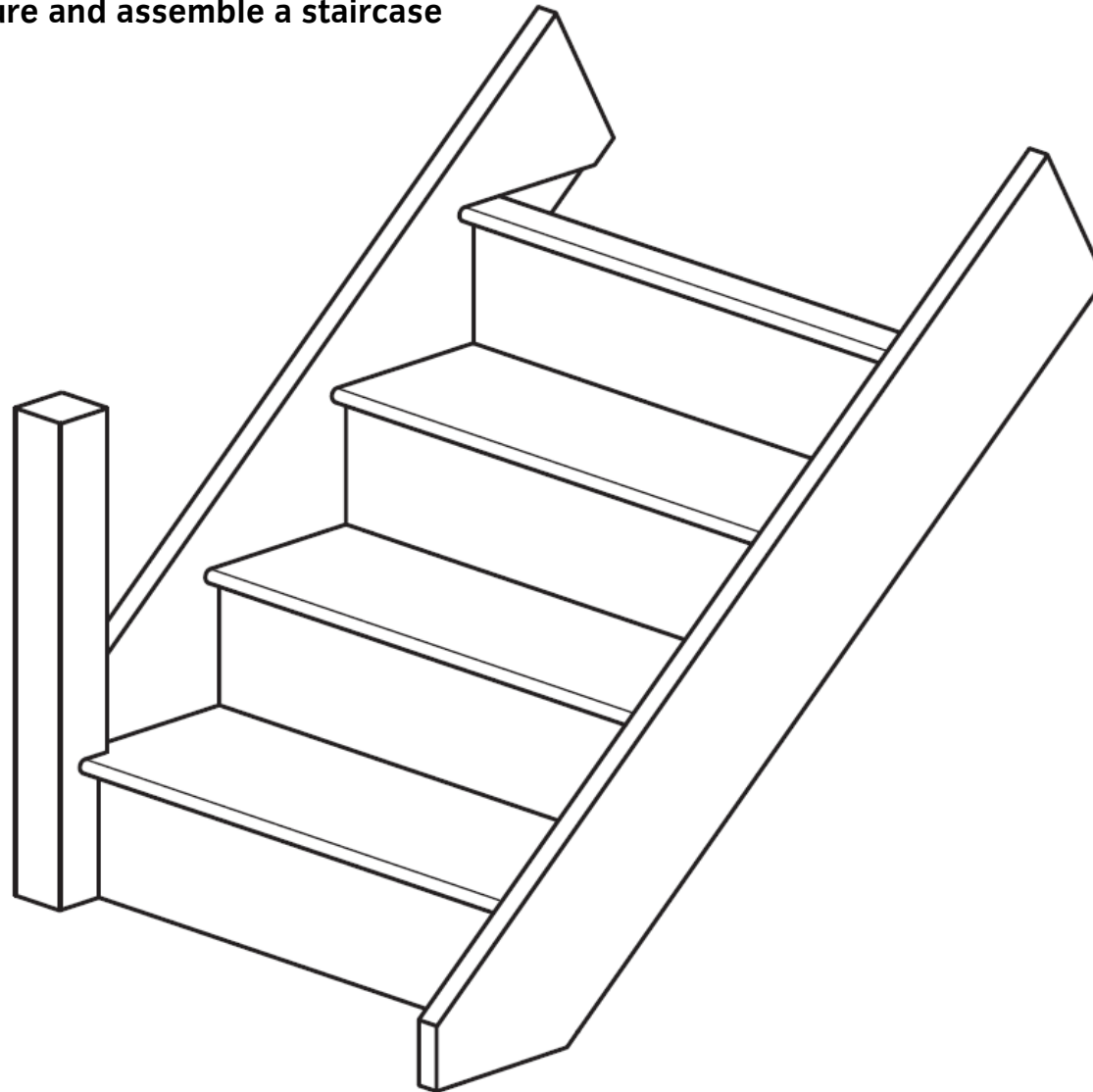

Drawings and diagrams

Unit 213 Mark out from setting out details for bench joinery products

Task 2 Mark out a staircase

Unit 214 Manufacture bench joinery products

Task 2 Manufacture and assemble a staircase

Figure 2: Staircase construction details

Diagram not to scale

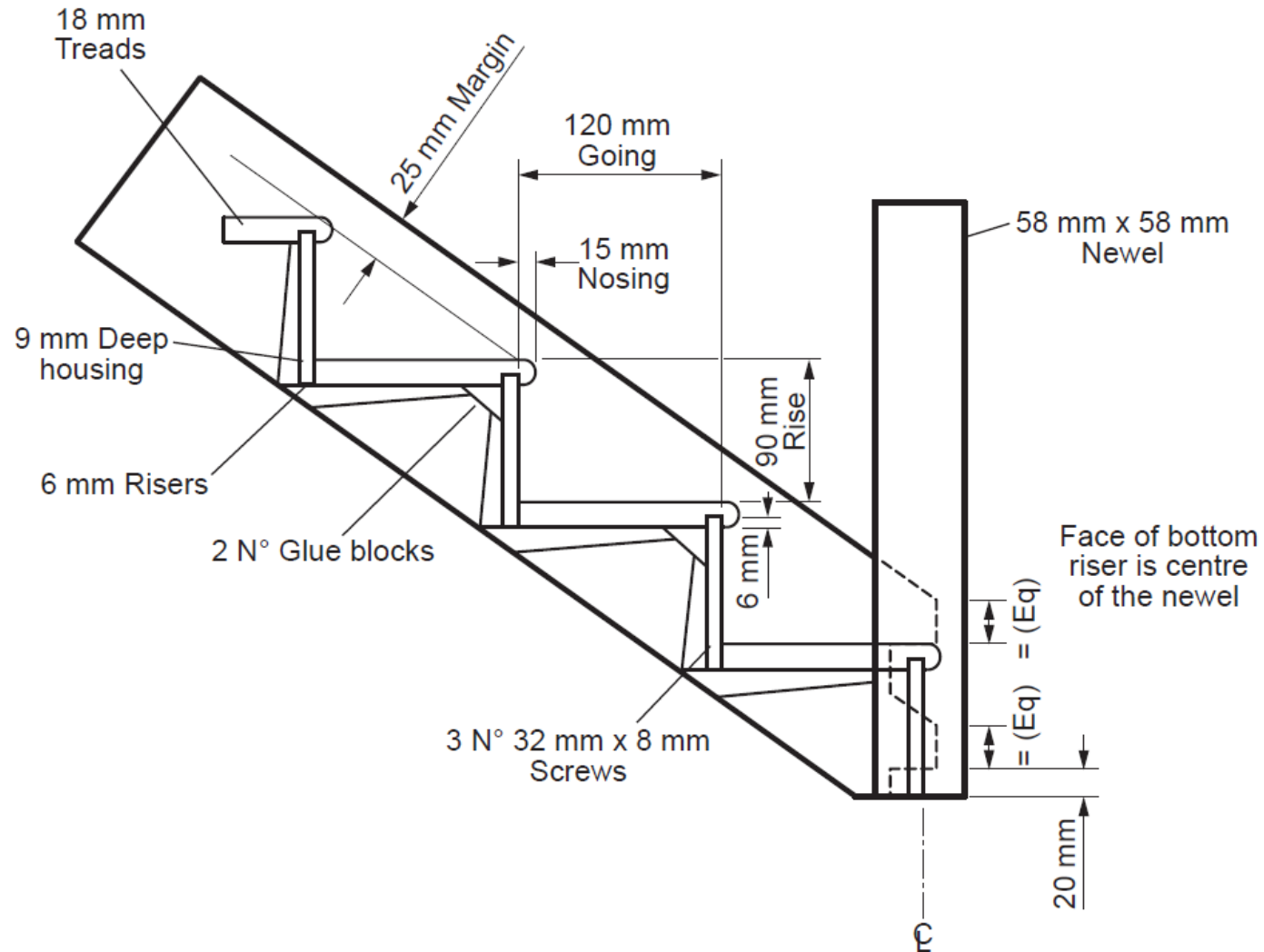

Drawings and diagrams

Unit 213 Mark out from setting out details for bench joinery products

Task 2 Mark out a staircase

Unit 214 Manufacture bench joinery products

Task 2 Manufacture and assemble a staircase

Figure 3: String to newel joint

Diagram not to scale

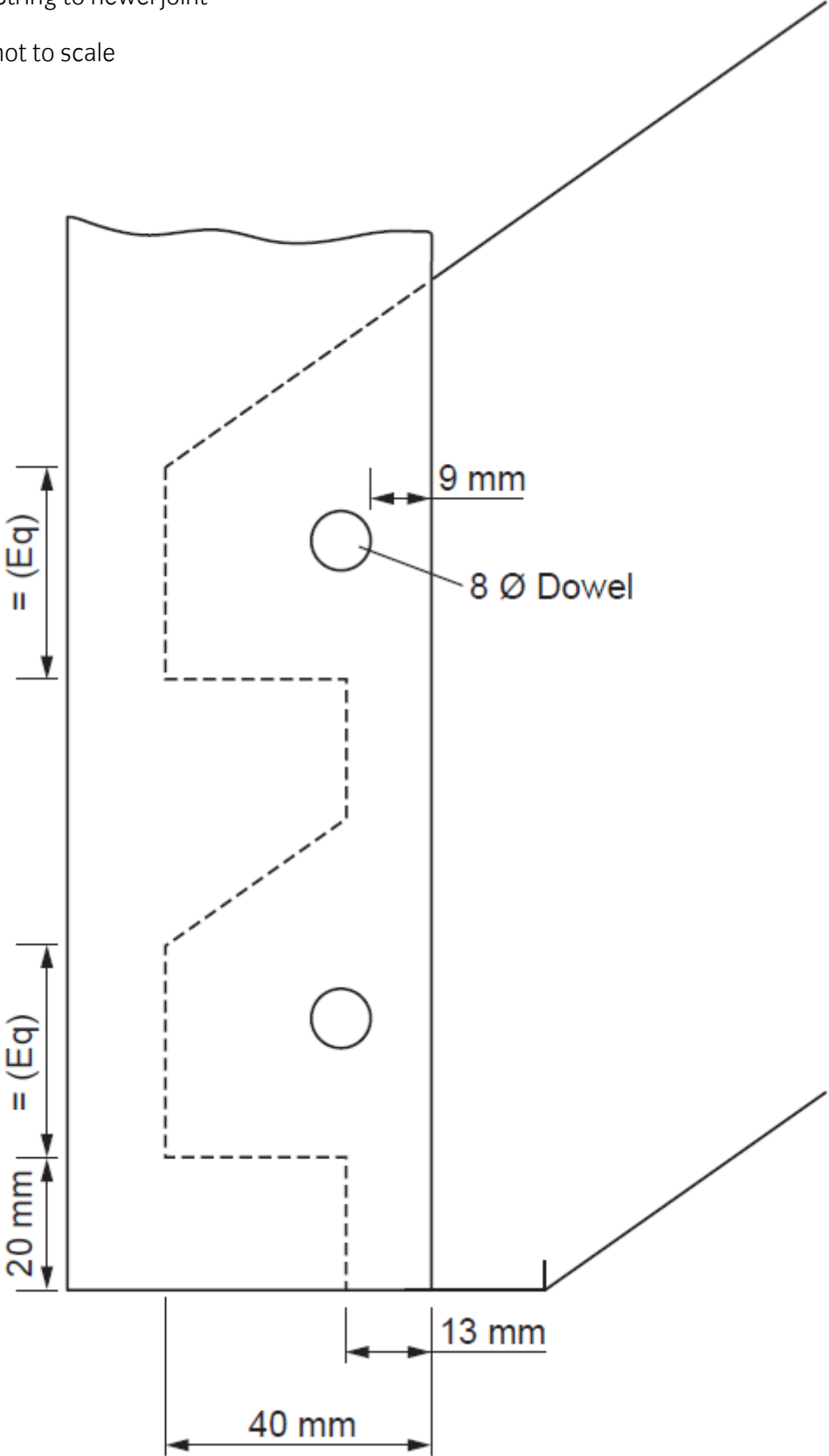

Drawings and diagrams

Unit 213 Mark out from setting out details for bench joinery products

Task 2 Mark out a staircase

Unit 214 Manufacture bench joinery products

Task 2 Manufacture and assemble a staircase

Figure 4: Bare faced tenon detail

Diagram not to scale

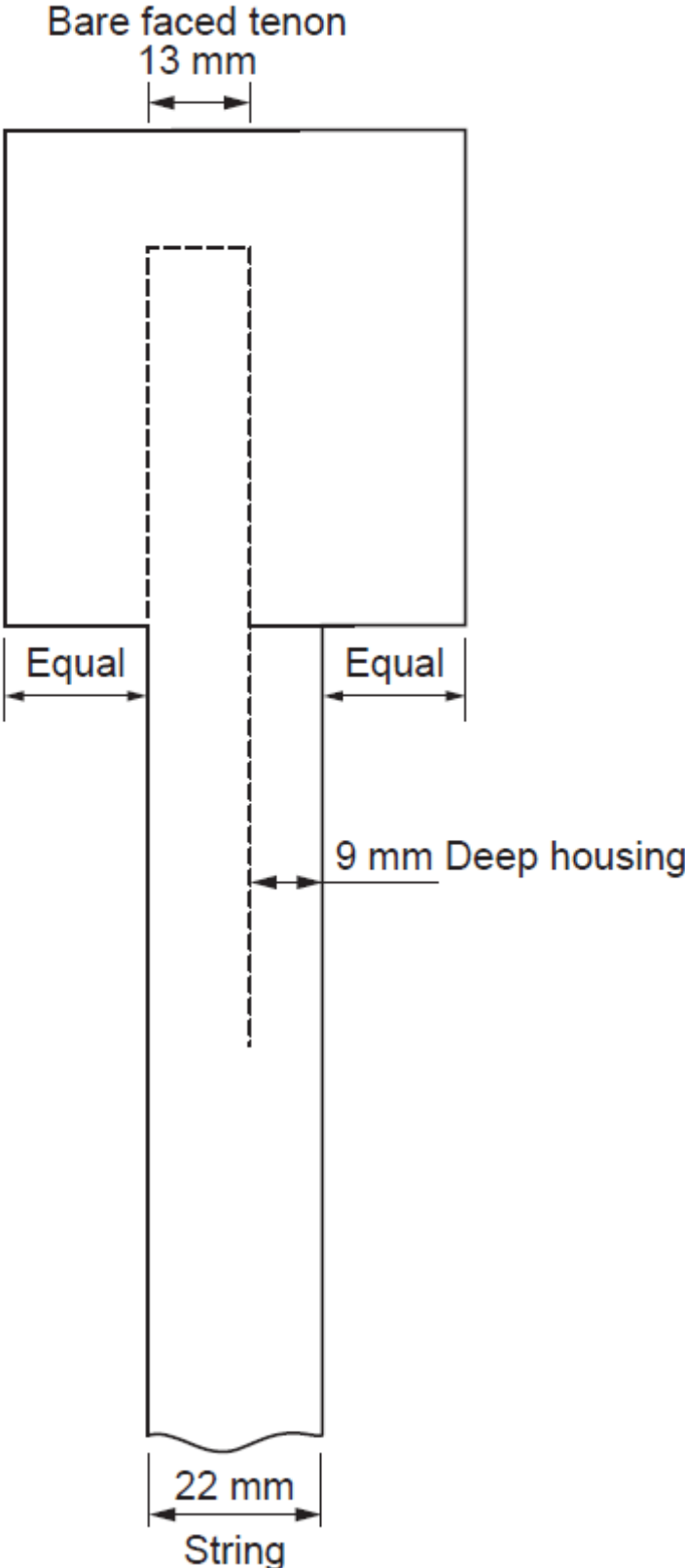

Published by City & Guilds
1 Giltspur Street
London
EC1A 9DD
T +44 (0)844 543 0000
F +44 (0)20 7294 2413
www.cityandguilds.com

**City & Guilds is a registered charity
established to promote education
and training**

About City & Guilds

As the UK's leading vocational education organisation, City & Guilds is leading the talent revolution by inspiring people to unlock their potential and develop their skills. We offer over 500 qualifications across 28 industries through 8500 centres worldwide and award around two million certificates every year. City & Guilds is recognised and respected by employers across the world as a sign of quality and exceptional training.

City & Guilds Group

The City & Guilds Group operates from three major hubs: London (servicing Europe, the Caribbean and Americas), Johannesburg (servicing Africa), and Singapore (servicing Asia, Australia and New Zealand). The Group also includes the Institute of Leadership & Management (management and leadership qualifications), City & Guilds Land Based Services (land-based qualifications), the Centre for Skills Development (CSD works to improve the policy and practice of vocational education and training worldwide) and Learning Assistant (an online e-portfolio).

Copyright

The content of this document is, unless otherwise indicated, © The City and Guilds of London Institute and may not be copied, reproduced or distributed without prior written consent. However, approved City & Guilds centres and candidates studying for City & Guilds qualifications may photocopy this document free of charge and/or include a PDF version of it on centre intranets on the following conditions:

- centre staff may copy the material only for the purpose of teaching candidates working towards a City & Guilds qualification, or for internal administration purposes
- candidates may copy the material only for their own use when working towards a City & Guilds qualification

The *Standard Copying Conditions* (see the City & Guilds website) also apply.

Published by City & Guilds, a registered charity established to promote education and training

Every effort has been made to ensure that the information contained in this publication is true and correct at the time of going to press. However, City & Guilds' products and services are subject to continuous development and improvement and the right is reserved to change products and services from time to time. City & Guilds cannot accept liability for loss or damage arising from the use of information in this publication.