

6219 Entry Level and Level 1 Awards, Certificates and Diplomas in Construction Skills



**Candidate task manual – Wall and floor tiling,
Construction operations, Painting and decorating**

www.cityandguilds.com
September 2013
Version 1.4

About City & Guilds

City & Guilds is the UK's leading provider of vocational qualifications, offering over 500 awards across a wide range of industries, and progressing from entry level to the highest levels of professional achievement. With over 8500 centres in 100 countries, City & Guilds is recognised by employers worldwide for providing qualifications that offer proof of the skills they need to get the job done.

City & Guilds Group

The City & Guilds Group includes City & Guilds, ILM (the Institute of Leadership & Management, which provides management qualifications, learning materials and membership services), City & Guilds HAB (the Hospitality Awarding Body), and City & Guilds Centre for Skills Development. City & Guilds also manages the Engineering Council Examinations on behalf of the Engineering Council.

Equal opportunities

City & Guilds fully supports the principle of equal opportunities and we are committed to satisfying this principle in all our activities and published material. A copy of our equal opportunities policy statement is available on our website.

Copyright

The content of this document is, unless otherwise indicated, © The City and Guilds of London Institute and may not be copied, reproduced or distributed without prior written consent.

However, approved City & Guilds centres and candidates studying for City & Guilds qualifications may photocopy this document free of charge and/or include a PDF version of it on centre intranets on the following conditions:

- centre staff may copy the material only for the purpose of teaching candidates working towards a City & Guilds qualification, or for internal administration purposes
- candidates may copy the material only for their own use when working towards a City & Guilds qualification

The *Standard Copying Conditions* (which can be found on our website) also apply.

Please note: National Occupational Standards are not © The City and Guilds of London Institute. Please check the conditions upon which they may be copied with the relevant Sector Skills Council.

Publications

City & Guilds publications are available from our website or from our Publications Sales department, using the contact details shown below.

Every effort has been made to ensure that the information contained in this publication is true and correct at the time of going to press. However, City & Guilds' products and services are subject to continuous development and improvement and the right is reserved to change products and services from time to time. City & Guilds cannot accept liability for loss or damage arising from the use of information in this publication.

City & Guilds

1 Giltspur Street

London EC1A 9DD

www.cityandguilds.com

candidatesupport@cityandguilds.com

6219 Entry Level and Level 1 Awards, Certificates and Diplomas in Construction Skills

**Candidate task manual – Wall and floor tiling,
Construction operations, Painting and decorating**

Version and date	Change detail	Section
V1.2 October 2014	Knowledge tasks removed to insert in separate 'End of unit knowledge questions' document.	Knowledge tasks
	Removal of references to permission for candidates to have marking criteria with them during practical tasks.	Practical tasks
V1.3 November 2014	Task completion records for assignments 101 and 102 added.	Unit assessment overview
	Assignment 116 Task A: Figure 1 updated.	Practical tasks
	Marking criteria tables: format standardised.	Practical tasks
V1.4 February 2016	Note added to Assignment 116 Task A Phone numbers deleted	Practical tasks Introduction and final pages

1	Unit assessment overview	5
1.1	Task completion record	5
2	Practical tasks	9
Assignment 003	Painting techniques	10
Assignment 111	Painting and wallpapering	13
Assignment 112	Applying decorative effects	16
Assignment 113	Applying wallpaper to internal and external angles and painting skirting	21
Assignment 114	Painting a panel door	24
Assignment 114	Painting a panel door	25
Assignment 004	Tiling a plain wall	27
Assignment 115	Cutting and fixing decorative panels	30
	panels	32
Assignment 116	Cutting and fixing tiles to wet areas	33
Assignment 116	Cutting and fixing tiles to wet area	34
Assignment 117	Tiling floors with a border	36
Assignment 006	Laying paving using slabs	39
Assignment 007	Setting out and laying gravel paths	42
Assignment 122	Laying block paving	45
Assignment 122	Laying block paving	46
Assignment 122	Laying block paving	47
Assignment 123	Laying underground domestic drainage	49
Assignment 124	Mixing and using concrete	53
3	Appendices	55
	Unit feedback and forward planning form	56
	Useful contacts	57

This *Candidate task manual* is a record of your achievement in practical assessments. You must keep it in good condition and it must be stored in a safe place by your Assessor. Please fill in all of your details before you carry out any assessments.

Candidate Details

Surname		Forename(s)	
City & Guilds enrolment number			

Centre Details

Name		Centre No	
------	--	-----------	--

I understand the requirements of the qualification and that all the work towards the assessments must be my own.

Candidate signature (please print)	
--	--

Assessor name (please print)		Signed	
--	--	--------	--

Date	
------	--

1 Unit assessment overview

1.1 Task completion record

To be completed by Assessor:

Assignment 101 Introduction to health and safety in construction

Task	Grade for task
A1 Why health and safety is important	P / X
A2 The role of the Health and Safety Executive	P / X
A3 Health and safety regulations	P / X
A4 Responsibility for health and safety	P / X
A5 Common causes of accidents in the construction industry - hazards	P / X
A6 Common causes of accidents in the construction industry - risks	P / X
A7 Risk assessment	P / X
A8 Health and safety sign categories	P / X
A9 Identify safety signs	P / X
A10 Identify COSSH signs	P / X
A11 Types of personal protective equipment (PPE)	P / X
A12 Purpose of personal protective equipment	P / X

All tasks must be passed for the unit to be achieved. Grading should be taken from the assessor guidance document. The overall grade should be calculated using the Marking Criteria in the Assessor Guide and transferred here.

Assessor signature and date:

Overall grade

P / M / D / X

Assignment 102 Introduction to the construction industry

Task	Grade for task
A1 Types of construction	P / X
A2 Sustainable construction	P / X
A3 Identify design features	P / X
A4 Energy saving materials used in the construction industry	P / X
A5 Construction industry activities	P / X
A6 Job opportunities in the construction industry	P / X

All tasks must be passed for the unit to be achieved. Grading should be taken from the assessor guidance document. The overall grade should be calculated using the Marking Criteria in the Assessor Guide and transferred here.

Assessor signature and date:

Overall grade

P / M / D / X

Unit 003 Painting techniques

Task	Grade for task
A Set out and paint a design	P / X
B Underpinning knowledge question	P / X

All tasks must be passed for the unit to be achieved.

Assessor signature and date: 	The overall grade will be pass/fail. <div style="text-align: right;"> Overall grade </div>
--------------------------------------	--

Unit 111 Painting and wallpapering

Task	Grade for task
A Practical task	P / M / D / X
B Oral/knowledge sheets	P / X

All tasks must be passed for the unit to be achieved.

Assessor signature and date: 	The overall grade will be the same as the single graded task in this unit. <div style="text-align: right;"> Overall grade </div>
--------------------------------------	--

Unit 112 Applying decorative effects

Task	Grade for task
A Apply decorative effects	P / X

All tasks must be passed for the unit to be achieved.

Assessor signature and date: 	The overall grade will be pass/fail. <div style="text-align: right;"> Overall grade </div>
--------------------------------------	--

Unit 113 Applying wallpaper to internal and external angles and painting skirting

Task	Grade for task
A Practical task	P / M / D / X
B Oral questioning	P / X

All tasks must be passed for the unit to be achieved.

Assessor signature and date: 	The overall grade will be the same as the single graded task in this unit. <div style="text-align: right;"> Overall grade </div>
--------------------------------------	--

Unit 114 Painting a panel door

Task	Grade for task
A Practical task	P / M / D / X
B Oral questions	P / X

All tasks must be passed for the unit to be achieved.

Assessor signature and date:

The overall grade will be the same as the single graded task in this unit.

Overall grade

Unit 004 Tiling a plain wall

Task	Grade for task
A Tile a plain wall	P / X

All tasks must be passed for the unit to be achieved.

Assessor signature and date:

The overall grade will be pass/fail.

Overall grade

Unit 115 Cutting and fixing decorative panels

Task	Grade for task
A Cut and fix a decorative panel	P / M / D / X

All tasks must be passed for the unit to be achieved.

Assessor signature and date:

The overall grade will be the same as the single graded task in this unit.

Overall grade

Unit 116 Cutting and fixing tiles to wet areas

Task	Grade for task
A Cut and fix tiles to a wet area	P / M / D / X

All tasks must be passed for the unit to be achieved.

Assessor signature and date:

The overall grade will be the same as the single graded task in this unit.

Overall grade

Unit 117 Tiling floors with a border

Task	Grade for task
A Tile a floor with a border	P / M / D / X

All tasks must be passed for the unit to be achieved.

Assessor signature and date:

The overall grade will be the same as the single graded task in this unit.

Overall grade

Unit 006 Laying paving using slabs

Task	Grade for task
A Lay a footpath	P / X

All tasks must be passed for the unit to be achieved.

Assessor signature and date:

The overall grade will be pass/fail.

Overall grade

Unit 007 Setting out and laying gravel paths

Task	Grade for task
A Set out and lay a gravel path	P / X
B Underpinning knowledge questions	P / X

All tasks must be passed for the unit to be achieved.

Assessor signature and date:

The overall grade will be pass/fail.

Overall grade

Unit 122 Laying block paving

Task	Grade for task
A Lay block paving	P / M / D / X
B Underpinning knowledge questions	P / X

All tasks must be passed for the unit to be achieved.

Assessor signature and date:

The overall grade will be the same as the single graded task in this unit.

Overall grade

Unit 123 Laying underground domestic drainage

Task	Grade for task
A Lay underground drainage	P / M / D / X
B Underpinning knowledge questions	P / X

All tasks must be passed for the unit to be achieved.

Assessor signature and date:

The overall grade will be the same as the single graded task in this unit.

Overall grade

Unit 124 Mixing and using concrete

Task	Grade for task
A Mix and use concrete	P / X

All tasks must be passed for the unit to be achieved.

Assessor signature and date:

The overall grade will be pass/fail.

Overall grade

2 Practical tasks

Assignment 003

Task A

Painting techniques

Set out and paint a design



To complete this task you must produce a suitable panel or wall area and apply the given design as shown on the diagram figure 1. Your assessor should check that the panel has a sufficient base coat and that the design is set out accurately before you start painting it.

You may have a copy of the diagrams during the practical assessment. Your assessor will support you with this.

This task can be achieved at pass only.

Figure 1

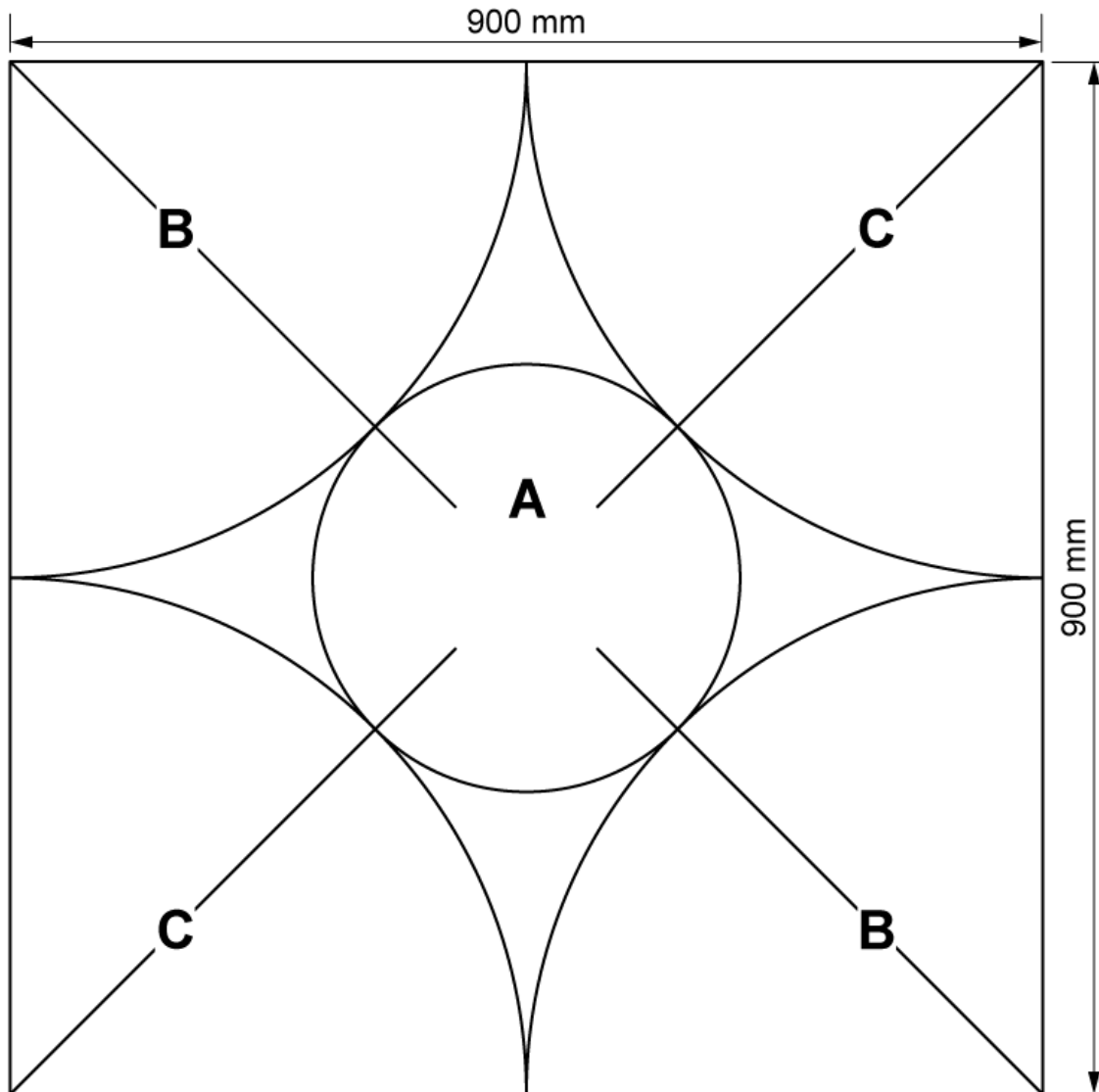

Specification

- A) Dark colour
- B) Light colour
- C) Contrast to A) and B)

The background colour should be 00E55 acrylic eggshell, soft sheen or vinyl matt.

Candidate name _____

Assessor name _____

Centre name _____

To pass the assignment, candidates are required to complete each task to the minimum standard indicated below.

The candidate has:	Pass	Merit	Distinction
identified and used Personal Protective Equipment (PPE) appropriate to preparing and applying paint to surfaces	<input type="checkbox"/>		
identified and selected the materials required to prepare and apply paint to a surfaces	<input type="checkbox"/>		
selected the tools and equipment required to prepare and apply paint to a surfaces	<input type="checkbox"/>		
prepared the background surface to given specifications	<input type="checkbox"/>		
prepared the paint to manufacturer's instructions	<input type="checkbox"/>		
applied base coat to surfaces to given specifications	<input type="checkbox"/>		
selected the tools and equipment required to mark out designs	<input type="checkbox"/>		
set out designs to surfaces to given specifications	<input type="checkbox"/>		
painted in the designs by brush to the given specifications	<input type="checkbox"/>		
set up the work area safely	<input type="checkbox"/>		
maintained a clean and safe working area following health and safety guidelines	<input type="checkbox"/>		
cleared the work area of surplus materials and debris on completion of the jobs	<input type="checkbox"/>		
cleaned all tools and equipment ready for re-use	<input type="checkbox"/>		

Assignment passed? Yes / No

Assessor signature _____

Date _____

To complete this task you must prepare a previously decorated wall for redecoration and produce a final wallpapered and painted surface.

In order to carry out this task you will need to follow the instructions and specifications given by your assessor.

You may have a copy of the diagrams during the practical assessment. Your assessor will support you with this.

This task can be achieved at pass, merit or distinction.

Candidate name _____

Assessor name _____

Centre name _____

To pass the assignment, candidates are required to complete each task to the minimum standard indicated below. All criteria for each grade must be achieved to claim that grade.

The candidate has:	Pass	Merit	Distinction
identified the Personal Protective Equipment (PPE) appropriate to preparing and decorating a wall surface	<input type="checkbox"/>		
identified the materials required to prepare and decorate a wall surface	<input type="checkbox"/>		
identified the tools and equipment required to prepare and decorate a wall surface	<input type="checkbox"/>		
stated methods used to prepare a previously decorated wall surface	<input type="checkbox"/>		
used Personal Protective Equipment (PPE) appropriate to preparing and decorating a wall surface	<input type="checkbox"/>		
selected the materials required to prepare and decorate a wall surface	<input type="checkbox"/>		
selected the tools and equipment required to prepare and decorate a wall surface	<input type="checkbox"/>		
prepared wall surface for wall papering	<input type="checkbox"/>		
selected the paperhanging tools and equipment	<input type="checkbox"/>		
selected the materials required to apply wallpaper to prepared wall surfaces	<input type="checkbox"/>		
prepared, measured and cut multiple lengths of wallpaper to a given specification	<input type="checkbox"/>		
prepared and pasted wallpaper in accordance with manufacturer's instructions	<input type="checkbox"/>		

The candidate has:	Pass	Merit	Distinction
Applied wallpaper within the following tolerances			
<ul style="list-style-type: none"> applied wall paper to a plumb line accurately to a tolerance of +/- 3mm 	<input type="checkbox"/>		
<ul style="list-style-type: none"> trimmed the wall paper accurately to size to a tolerance of +/- 3mm 	<input type="checkbox"/>		
<ul style="list-style-type: none"> butt jointed the wallpaper accurately to a tolerance of +/- 3mm 	<input type="checkbox"/>		
selected tools and equipment for painting	<input type="checkbox"/>		
prepared the paint to manufacturers' instructions	<input type="checkbox"/>		
applied paint using different painting techniques within a tolerance of +/- 3mm	<input type="checkbox"/>		
demonstrated safe setup of the work area.	<input type="checkbox"/>		
maintained a clean and safe working area following health and safety guidelines	<input type="checkbox"/>		
cleared the work area of surplus materials and debris on completion of the job	<input type="checkbox"/>		
cleaned all tools and equipment ready for re-use.	<input type="checkbox"/>		
completed the task with	<input type="checkbox"/> 3 defects	<input type="checkbox"/> 2 defects	<input type="checkbox"/> 1 defect

Assignment passed?

Yes / No

Final grade Pass/Merit/Distinction

Assessor signature _____

Date _____

To complete this task you must

- prepare and paint ground coat to panels
- apply decorative effects to panels
- cut and apply a stencil as shown on the diagram (Figure 2).

You must apply straight grain border as shown in the diagram (Figure 1) and two other types of decorative effects that you have chosen from the range. You should follow your assessor's instructions throughout the task.

Your chosen stencil will need to be approved by your assessor for use.

This task may be achieved at pass only.

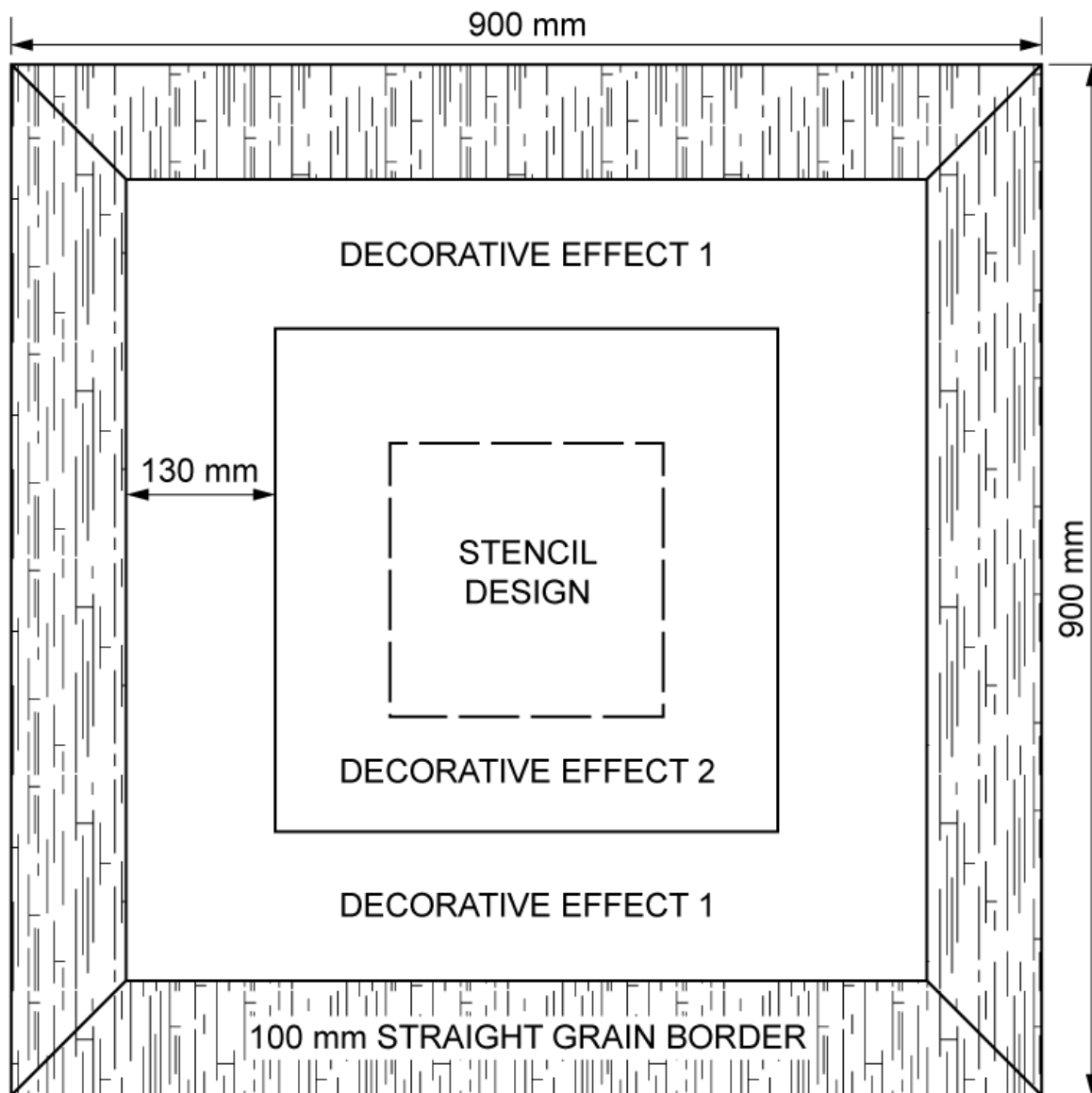
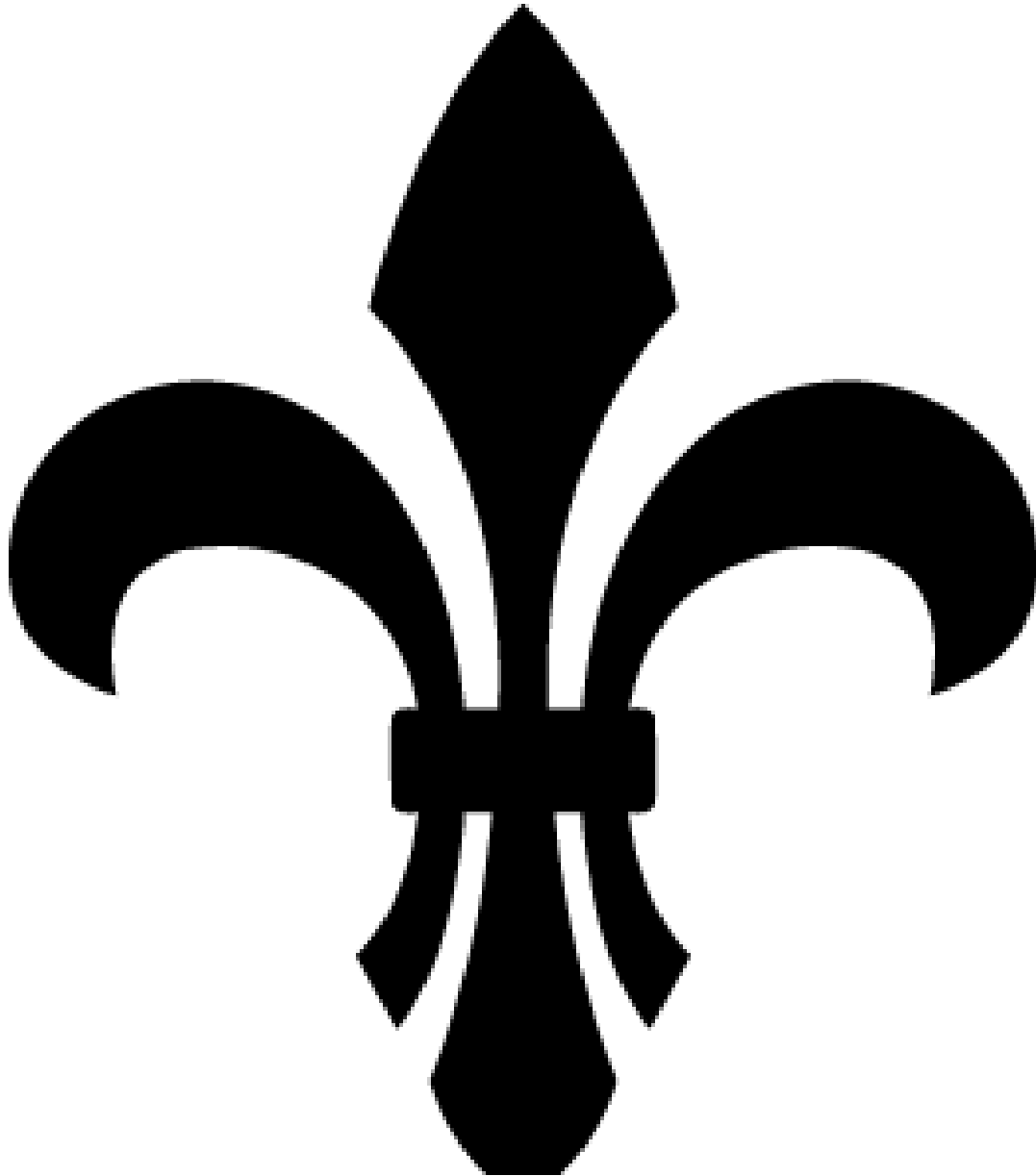

Figure 2



Assignment 112 Applying decorative effects
 Marking criteria Task A



Candidate name _____

Assessor name _____

Centre name _____

To pass the assignment, candidates are required to complete each task to the minimum standard indicated below.

The candidate has:	Pass	Merit	Distinction
identified and used Personal Protective Equipment (PPE) appropriate to preparing and decorating wall surfaces and applying decorative effects	<input type="checkbox"/>		
identified the materials required to apply decorative effects	<input type="checkbox"/>		
identified the tools and equipment required to apply decorative effects	<input type="checkbox"/>		
stated/used methods to prepare and paint ground coat to panels	<input type="checkbox"/>		
stated/applied the different types decorative effects	<input type="checkbox"/>		
stated/used methods of applying decorative effects to panels	<input type="checkbox"/>		
stated/followed the process for cutting and applying stencils	<input type="checkbox"/>		
selected tools and equipment for painting panels	<input type="checkbox"/>		
selected the materials required to prepare and decorate wall surfaces	<input type="checkbox"/>		
prepared and painted ground coat to panels for application of decorative effects	<input type="checkbox"/>		
measured and set out areas for application of decorative effects to given specifications	<input type="checkbox"/>		
applied protective tape and masking where required	<input type="checkbox"/>		
prepared materials for application of decorative effects to manufacturer's instructions	<input type="checkbox"/>		
selected tools and equipment to produce decorative effects to given specifications	<input type="checkbox"/>		
produced decorative effects on panels to the given specifications	<input type="checkbox"/>		

The candidate has:	Pass	Merit	Distinction
selected tools, equipment and materials to make and size stencils	<input type="checkbox"/>		
applied the design and cut out the stencil	<input type="checkbox"/>		
applied paint to create a stencil design	<input type="checkbox"/>		
setup the work area safely	<input type="checkbox"/>		
maintained a clean and safe working area following health and safety guidelines	<input type="checkbox"/>		
cleared the work area of surplus materials and debris on completion of the jobs	<input type="checkbox"/>		
cleaned all tools and equipment ready for re-use	<input type="checkbox"/>		

Assignment passed? Yes / No

Assessor signature _____

Date _____

Assignment 113

Applying wallpaper to internal and external angles and painting skirting



Task A

Practical task

In order to complete this task you must prepare a wall with internal and external angles and hang wallpaper according to your assessor's instructions and prepare and paint skirting boards.

You may have a copy of the diagrams during the practical assessment. Your assessor will support you with this.

This task can be achieved at pass, merit or distinction.

Assignment 113

Applying wallpaper to internal and external angles and painting skirting



Marking criteria

Task A

Candidate name _____

Assessor name _____

Centre name _____

To pass the assignment, candidates are required to complete each task to the minimum standard indicated below. All criteria for each grade must be achieved to claim that grade.

The candidate has:	Pass	Merit	Distinction
identified and used Personal Protective Equipment (PPE) appropriate to preparing and decorating wall surfaces and skirting	<input type="checkbox"/>		
identified materials required to prepare and decorate wall surfaces and skirting	<input type="checkbox"/>		
identified tools and equipment required to prepare and decorate wall surfaces and skirting	<input type="checkbox"/>		
Stated/ used methods to prepare a previously decorated wall surface and painted skirting	<input type="checkbox"/>		
selected materials required to prepare and decorate wall surfaces	<input type="checkbox"/>		
selected tools and equipment required to prepare and decorate wall surfaces	<input type="checkbox"/>		
prepared the wall surface for wallpapering	<input type="checkbox"/>		
selected paperhanging tools and equipment required to apply wallpaper to internal and external angles	<input type="checkbox"/>		
selected materials required to apply wallpaper to internal and external angles	<input type="checkbox"/>		
prepared, measured and cut lengths of wallpaper within a tolerance of +/- 3mm	<input type="checkbox"/>		
prepared and pasted wallpaper in accordance with manufacturer's instructions	<input type="checkbox"/>		
hung wallpaper within a tolerance of +/- 3mm	<input type="checkbox"/>		

The candidate has:	Pass	Merit	Distinction
butt jointed the wallpaper within a tolerance of +/- 3mm	<input type="checkbox"/>		
used Personal Protective Equipment (PPE) appropriate to prepare and paint skirting	<input type="checkbox"/>		
selected the materials required to prepare skirting boards	<input type="checkbox"/>		
selected tools required to prepare and paint skirting boards	<input type="checkbox"/>		
prepared skirting boards for painting	<input type="checkbox"/>		
prepared paint to manufacturer's instructions	<input type="checkbox"/>		
applied paint by brush to skirting	<input type="checkbox"/>		
cut in and painted the skirting using correct brush techniques to a tolerance of +/- 3mm	<input type="checkbox"/>		
setup the work area safely	<input type="checkbox"/>		
maintained a clean and safe working area following health and safety guidelines	<input type="checkbox"/>		
cleared the work area of surplus materials and debris on completion of the jobs	<input type="checkbox"/>		
cleaned all tools and equipment ready for re-use.	<input type="checkbox"/>		
completed the task within the tolerances and with	<input type="checkbox"/> 5 defects (no more than 3 for papering and 2 for painting)	<input type="checkbox"/> 3 defects (no more than 2 for papering and 1 for painting)	<input type="checkbox"/> 2 defects (no more than 1 for papering and 1 for painting)

Assignment passed?

Yes / No

Final grade Pass/Merit/Distinction

Assessor signature _____

Date _____

Assignment 114 **Painting a panel door**
Task A Practical task

To complete this task you must remove paint from one panel of a previously painted door, prime the bare surfaces and prepare the remaining sections of the door for painting. You should produce a final painted panel door by brush and/or roller in the correct sequence and as instructed by your assessor.

You may have a copy of the diagrams during the practical assessment. Your assessor will support you with this.

This task can be achieved at pass, merit or distinction.

Assignment 114 Painting a panel door
 Marking criteria Task A



Candidate name _____

Assessor name _____

Centre name _____

To pass the assignment, candidates are required to complete each task to the minimum standard indicated below. All criteria for each grade must be achieved to claim that grade.

The candidate has:	Pass	Merit	Distinction
identified Personal Protective Equipment (PPE) appropriate to preparing panel doors for painting	<input type="checkbox"/>		
identified materials required to prepare panel doors for painting	<input type="checkbox"/>		
identified tools and equipment required to prepare panel doors for painting	<input type="checkbox"/>		
stated the correct sequences to painting panel doors	<input type="checkbox"/>		
used Personal Protective Equipment (PPE) appropriate to preparing panel doors for painting and painting panel doors	<input type="checkbox"/>		
selected materials required to prepare panel doors for painting	<input type="checkbox"/>		
selected tools and equipment required to prepare panel doors for painting	<input type="checkbox"/>		
prepared the panel doors to given specifications	<input type="checkbox"/>		
selected tools required to paint panel doors	<input type="checkbox"/>		
prepared paint to manufacturer's instructions	<input type="checkbox"/>		
applied paint to panel door to given specifications	<input type="checkbox"/>		
completed with a maximum of	<input type="checkbox"/> 3 defects	<input type="checkbox"/> 2 defects	<input type="checkbox"/> 1 defect
demonstrated safe setup of the work area	<input type="checkbox"/>		
maintained a clean and safe working area following health and safety guidelines	<input type="checkbox"/>		
cleared the work area of surplus materials and debris on completion of the job	<input type="checkbox"/>		
Cleaned all tools and equipment ready for re-use.	<input type="checkbox"/>		

Assignment passed? Yes / No **Final grade** Pass/Merit/Distinction

Assessor signature _____

Date _____

Assignment 004 **Tiling a plain wall**
Task A Tile a plain wall

To complete this task you must prepare a wall surface, set out, fix tiles to a plain wall and finish tiles to the dimensions given on the diagram in figure 1.

You may have a copy of the diagrams during the practical assessment. Your assessor will support you with this.

You have five hours to complete this task.

This task can be achieved at pass only.

Figure 1

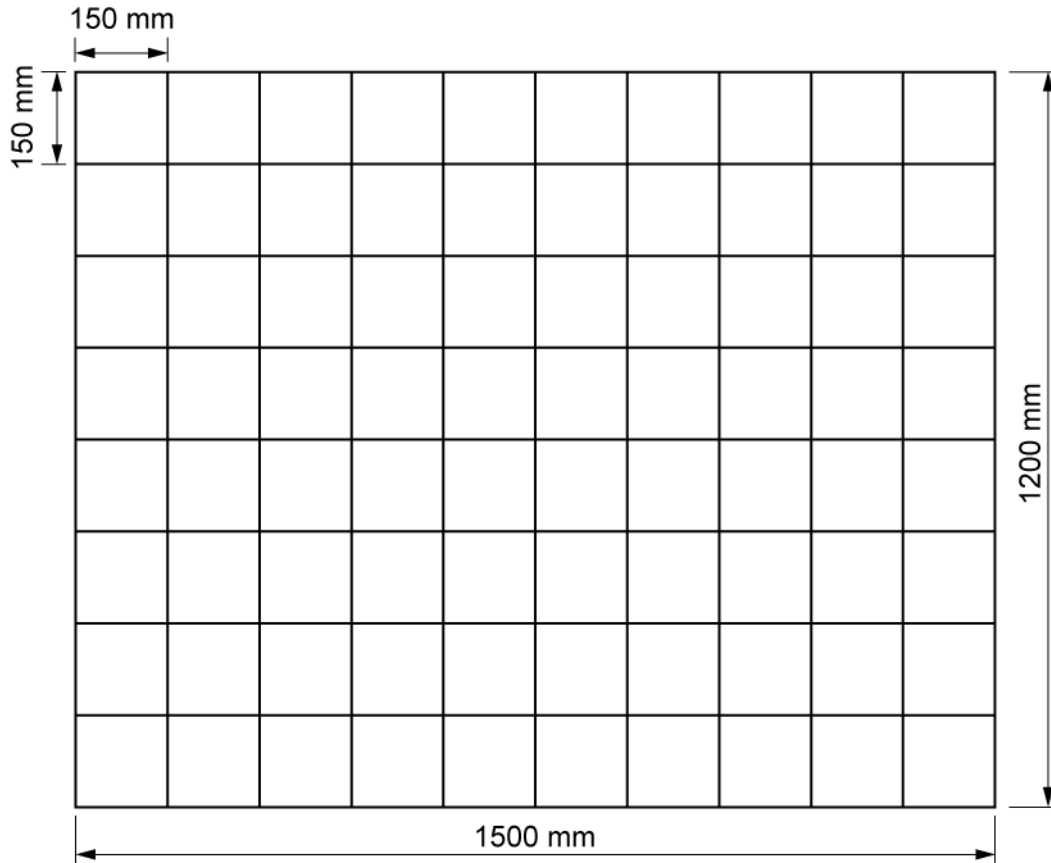

Specification

Tile size should be 150mm x 150mm.

Area to be tiled should be 1500mm x 1200mm.

Assignment 004 Tiling a plain wall
 Marking criteria Task A



Candidate name _____

Assessor name _____

Centre name _____

To pass the assignment, the candidate is required to complete each task to the minimum standard indicated below.

The candidate has:	Pass	Merit	Distinction
identified and used appropriate personal protective equipment (PPE)	<input type="checkbox"/>		
identified and selected the materials required	<input type="checkbox"/>		
identified and selected the tools and equipment required to prepare and tile surfaces	<input type="checkbox"/>		
prepared surfaces for tiles to given specifications	<input type="checkbox"/>		
hand mixed adhesive to manufacturer's instructions	<input type="checkbox"/>		
set out a datum line to given specifications	<input type="checkbox"/>		
applied adhesive ready to receive tiles – 50% coverage	<input type="checkbox"/>		
fixed tiles to given specifications, grout joints were even and did not exceed 3mm	<input type="checkbox"/>		
laid tiles plumb and level to +/-5mm	<input type="checkbox"/>		
applied wall grout consistently to tiled areas	<input type="checkbox"/>		
cleaned and polished tiles ready for use – free from grout residue	<input type="checkbox"/>		
demonstrated safe setup of the work area	<input type="checkbox"/>		
maintained a clean and safe working area and has followed health and safety guidelines	<input type="checkbox"/>		
cleared work area of surplus materials and debris on completion of the job	<input type="checkbox"/>		
cleaned all tools and equipment ready for re-use	<input type="checkbox"/>		

Assignment passed? Yes / No

Assessor signature _____

Date _____

Candidate name _____

Assessor name _____

Centre name _____

To pass this task you are required to cut and fix tiles to a decorative panel and finish tiles to the specification in the diagram provided (figure 1). You are also required to answer one oral question about preparing walls for tiling.

The task should be carried out on a suitable wall area which is a maximum of 2m². Tile size should be 150mm x 150mm.

You should set out from the centre, mark, cut and shape tiles prior to applying adhesive. You should then mix the adhesive per the manufacturers' instructions before applying an even bed of adhesive. This task may be achieved at pass, merit or distinction according to the tolerances in the marking criteria.

You may have a copy of the diagrams during the practical assessment. Your assessor will support you with this.

You are allowed five hours to complete this task.

Candidate answer record

a)	
b)	

Figure 1

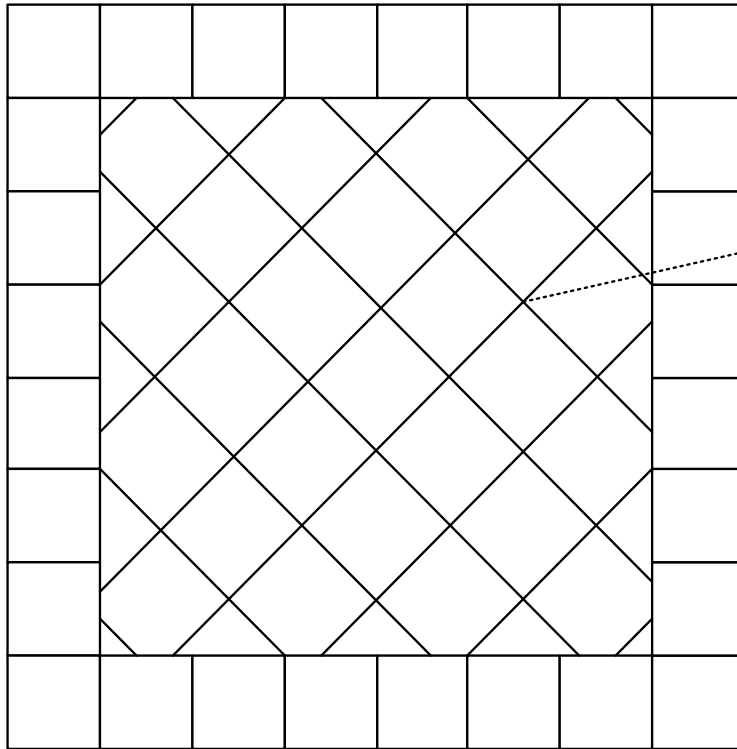

Tiles to be set on the diagonal in the centre

Specification

Wall area of should be a maximum of 2m².
Tile size should be 150mm x 150mm.

Assignment 115 Cutting and fixing decorative panels



Marking criteria Task A

Candidate name _____

Assessor name _____

Centre name _____

To pass the assignment, the candidate is required to complete each task to the minimum standard indicated below. All criteria for each grade must be achieved to claim that grade.

The candidate has:	Pass	Merit	Distinction
identified and used the personal protective equipment (PPE)	<input type="checkbox"/>		
identified and selected the materials required	<input type="checkbox"/>		
identified and selected the tools and equipment required	<input type="checkbox"/>		
selected tiles to complete the given pattern	<input type="checkbox"/>		
successfully set out, cut and fixed wall tiles to the pattern and to given specifications plumb and level	<input type="checkbox"/> +/-4mm	<input type="checkbox"/> +/-3mm	<input type="checkbox"/> +/-2mm
applied grout to tiled areas	<input type="checkbox"/>		
cleaned and polished tiles	<input type="checkbox"/>		
demonstrated safe setup of the work area	<input type="checkbox"/>		
maintained a clean and safe working area following health and safety guidelines	<input type="checkbox"/>		
cleared the work area of surplus materials and debris on completion of the job	<input type="checkbox"/>		
cleaned all tools and equipment ready for re-use	<input type="checkbox"/>		
correctly answered question	<input type="checkbox"/>		

Assignment passed? **Final Grade** - Pass/Merit/Distinction

Assessor signature _____

Date _____

Candidate name _____

Assessor name _____

Centre name _____

You must cut and fix tiles to a wet area and finish tiles to the specifications in the diagram (Figure 1) provided and to the tolerances in the grading criteria. You are also required to answer one oral question about preparing wet areas.

You may have a copy of the diagrams during the practical assessment. Your assessor will support you with this.

You must also answer a question relating to wet areas which may be asked orally or in written format.

You have eight hours to complete this task.

Candidate answer record

a)

Figure 1*

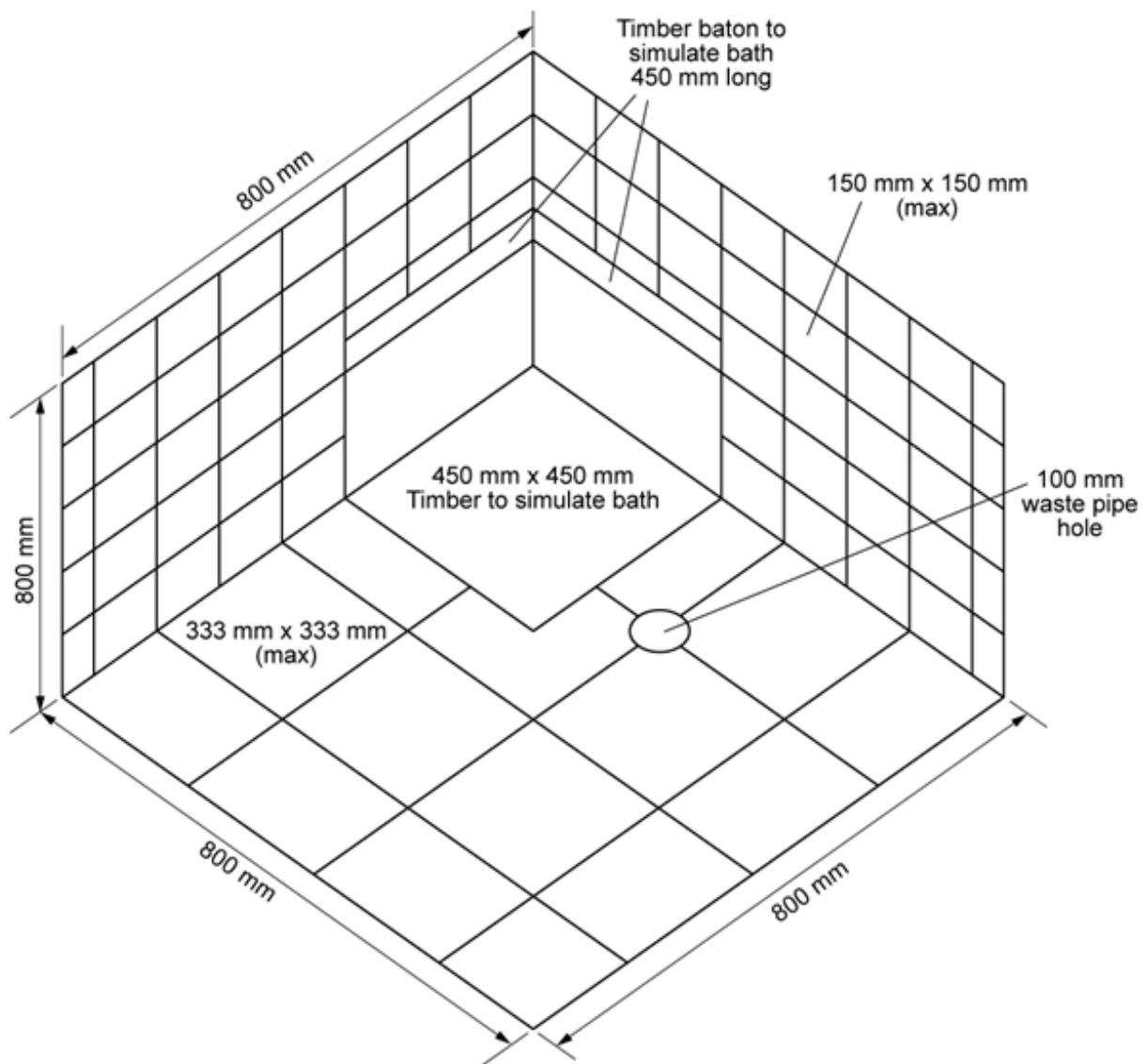

*Final design and look of Figure 1 depends on the size of tiles used within the 800 mm x 800 mm wall and floor area

Candidate name _____

Assessor name _____

Centre name _____

To pass the assignment, the candidate is required to complete each task to the minimum standard indicated below. All criteria for each grade must be achieved to claim that grade.

The candidate has:	Pass	Merit	Distinction
identified selected and used the appropriate personal protective equipment (PPE)	<input type="checkbox"/>		
identified and selected materials	<input type="checkbox"/>		
identified and selected tools and equipment required	<input type="checkbox"/>		
prepared areas to receive floor and wall tiles to given specification	<input type="checkbox"/>		
cleaned and polished tiles ready for use	<input type="checkbox"/>		
setup the work area safely	<input type="checkbox"/>		
maintained a clean and safe working area following health and safety guidelines	<input type="checkbox"/>		
Cleared the work area	<input type="checkbox"/>		
correctly stated the methods of preparing wet areas	<input type="checkbox"/>		
successfully set out wall and floor area to given specifications	<input type="checkbox"/>		
cut and fixed wall and floor tiles for wet areas to given specifications within the tolerances below:	<input type="checkbox"/>		
<ul style="list-style-type: none"> Plumb and level 	<input type="checkbox"/> +/- 4mm	<input type="checkbox"/> +/- 3mm	<input type="checkbox"/> +/- 2mm
<ul style="list-style-type: none"> Square and flat 	<input type="checkbox"/> +/- 4mm	<input type="checkbox"/> +/- 3mm	<input type="checkbox"/> +/- 2mm
applied an even bed of adhesive ready to receive tiles	<input type="checkbox"/>		
fixed wall and floor tiles to wet areas and kept in line	<input type="checkbox"/>		
mixed and applied grout to wall and floor tiles	<input type="checkbox"/>		

Assignment passed? _____ **Final Grade** Pass/Merit/Distinction

Assessor signature _____

Date _____

Candidate name _____

Assessor name _____

Centre name _____

You should set out, cut and fix tiles to a patterned floor and finish tiles to the specifications in the diagram (figure 1) provided. You must also answer two oral questions about fixing floor tiles to different types of floors.

You should mark out and cut tiles prior to applying adhesive. The adhesive should be mixed as per the manufacturers' instructions before applying an even bed.

You have seven hours to complete this task.

This task may be achieved at pass, merit or distinction.

Candidate answer record

1)	
2)	

Figure 1

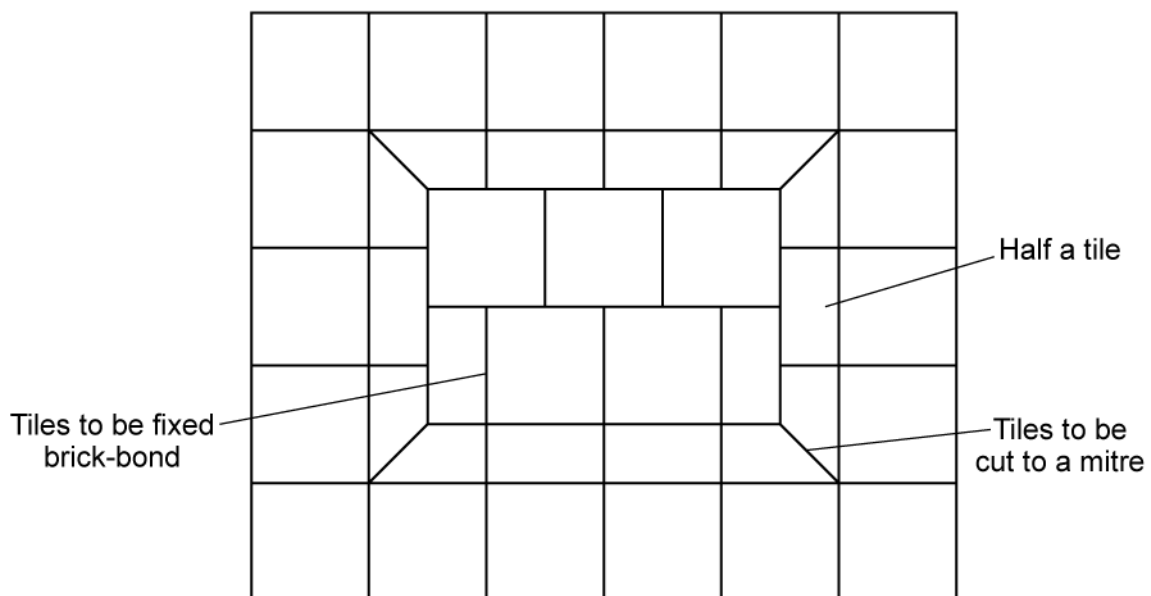

Specification

- Suitable timber or screed floor which is a minimum of 1.5m².
- Tile size should be a maximum of 333mm x 333mm.
- Tiles to be cut in half to form the border with mitred corners.
- Centre of the floor to be laid in a brick-bond pattern.

Assignment 117 **Tiling floors with a border**
 Marking criteria Task A



Candidate name _____

Assessor name _____

Centre name _____

To pass the assignment, candidates are required to complete each task to the minimum standard indicated below. All criteria for each grade must be achieved to claim that grade.

The candidate has:	Pass	Merit	Distinction
identified and used appropriate personal protective equipment (PPE)	<input type="checkbox"/>		
set up the work area safely	<input type="checkbox"/>		
identified and selected the appropriate materials	<input type="checkbox"/>		
identified and selected the appropriate tools and equipment	<input type="checkbox"/>		
selected tiles required to complete the given pattern	<input type="checkbox"/>		
set out, cut and laid floor tiles to the pattern and to the given specifications within the following tolerances			
<ul style="list-style-type: none"> flat and square 	<input type="checkbox"/> +/- 4mm	<input type="checkbox"/> +/- 3mm	<input type="checkbox"/> +/-2mm
applied grout to tiled areas	<input type="checkbox"/>		
cleaned and polished tiles ready for use	<input type="checkbox"/>		
maintained a clean and safe working area and has followed health and safety guidelines	<input type="checkbox"/>		
cleared the work area of surplus materials and debris on completion of the job	<input type="checkbox"/>		
cleaned all tools and equipment ready for re-use	<input type="checkbox"/>		
correctly answered the two questions	<input type="checkbox"/>		

Assignment passed? **Final Grade** Pass/Merit/Distinction

Assessor signature _____

Date _____

Assignment 006 **Laying paving using slabs**
Task A Lay a footpath



Candidate name _____

Assessor name _____

Centre name _____

To complete this task you must lay a footpath in 450mm slabs 4 slabs long and 2 slabs wide on a bed of sand with a fall of 20mm across the footpath to the specification and tolerances in the diagram (Figure 1) provided.

You must:

- prepare a work area to set out and lay the path
- ensure that you wear appropriate PPE and maintain a clean and safe working environment at all times
- select the tools, equipment and materials required to complete the task
- measure and set out the area for the path to the given specifications
- source the number of slabs required to lay the path to the given specifications
- position slabs and bedding material ready for use
- bed slabs to the given specifications
- on completion of the task clear your work area of all debris before marking takes place
- clean all tools and equipment ready for re-use

You must work safely at all times in line with the health and safety guidelines. If the assessor believes that you are doing anything which may harm yourself or others they will stop your assessment.

In addition you will be asked two questions which must be answered correctly.

This task can be achieved at pass only.

You have two hours to complete this task.

Candidate answer record

No.	Answer	Achieved
1	_____	_____
2	_____	_____

Figure 1

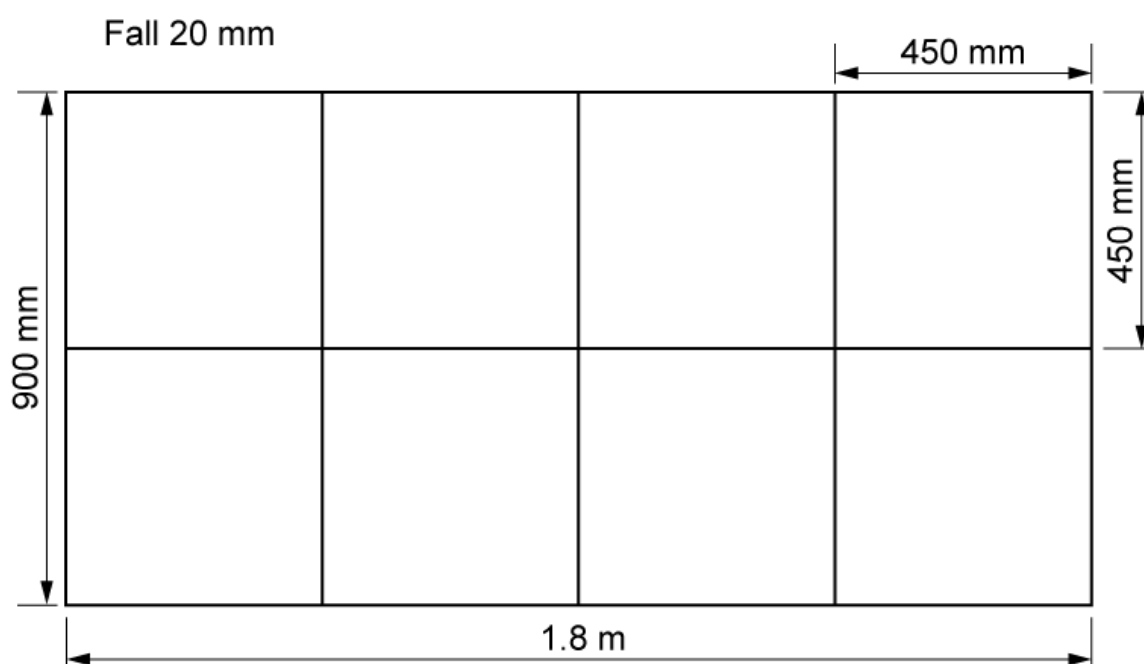

Specification

Setting out (length)	+/- 30mm in the length of the path
Setting out (width)	+ or -15mm in the width of the path
Level	+/- 40mm in the length of the path
Fall mm across the width	20mm +/- 15mm
Stability of slabs	No excessive movement of slabs

Assignment 006 **Laying paving using slabs**
 Marking criteria Task A



Candidate name _____

Assessor name _____

Centre name _____

To pass the assignment, the candidate is required to complete each task to the minimum standard indicated below.

The candidate has:	Pass	Merit	Distinction
identified the personal protective equipment (PPE) appropriate to laying the slabs	<input type="checkbox"/>		
identified the materials required to complete the task	<input type="checkbox"/>		
identified the tools and equipment required to lay the slabs	<input type="checkbox"/>		
used personal protective equipment (PPE) appropriate to laying the slabs	<input type="checkbox"/>		
selected the materials, tools and equipment required to lay the slabs	<input type="checkbox"/>		
demonstrated safe setup of the work area	<input type="checkbox"/>		
lay slabs to the specifications provided and within the following tolerances:	<input type="checkbox"/>		
setting out (length) +/-30mm in the length of the path	<input type="checkbox"/>		
setting out (width) +/-15mm in the width of the path	<input type="checkbox"/>		
level +/-40mm in the length of the path	<input type="checkbox"/>		
fall across the width 20 mm +/-15mm in the length of the path	<input type="checkbox"/>		
stability of slabs - no excessive movement of slabs	<input type="checkbox"/>		
maintained a clean and safe working area and has followed health and safety guidelines	<input type="checkbox"/>		
cleared work area of surplus materials and debris on completion of the job	<input type="checkbox"/>		
cleaned all tools and equipment ready for re-use	<input type="checkbox"/>		
correctly answered first question	<input type="checkbox"/>		
chosen answered second question	<input type="checkbox"/>		

Assignment passed? Yes / No

Assessor signature _____

Date _____

To complete task A you should set out and fix path edging, lay using either timber or concrete and lay and level sub base and gravel path to the specifications on the diagram provided.

You must work safely at all times in line with the centre's health and safety guidelines. If the assessor believes that you are doing anything which may harm yourself or others they will stop your assessment.

You have two hours to complete this task.

Figure 1

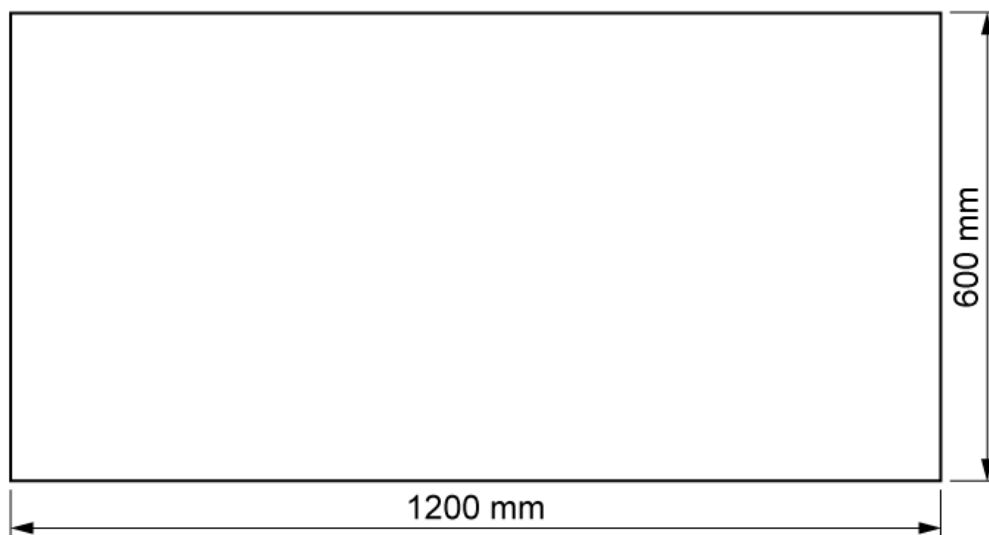

Plan

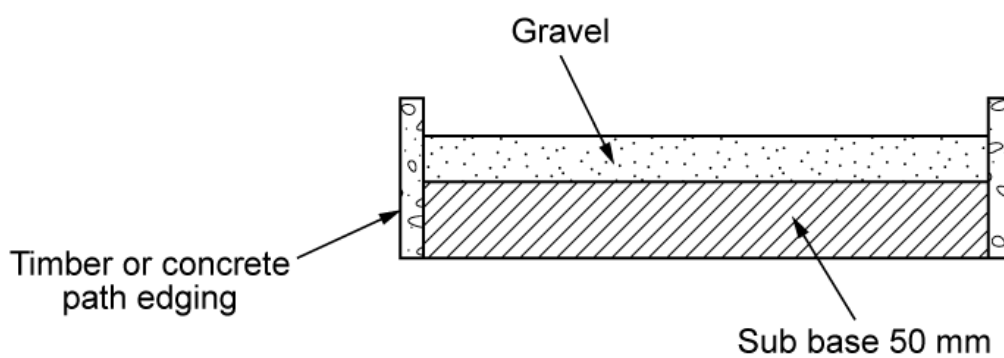

Cross Section

Candidate name _____

Assessor name _____

Centre name _____

To pass the assignment, the candidate is required to complete each task to the minimum standard indicated below.

The candidate has:	Pass	Merit	Distinction
identified the personal protective equipment (PPE) appropriate to laying the slabs	<input type="checkbox"/>		
identified the materials required to complete the task	<input type="checkbox"/>		
identified the tools and equipment required to fix path edging	<input type="checkbox"/>		
used personal protective equipment (PPE) appropriate to the task	<input type="checkbox"/>		
selected the tools and equipment required to lay path.	<input type="checkbox"/>		
demonstrated safe setup of the work area	<input type="checkbox"/>		
set out the path within the following tolerances:	<input type="checkbox"/>		
<ul style="list-style-type: none"> • +/-50mm in the length of the path 	<input type="checkbox"/>		
<ul style="list-style-type: none"> • +/-30mm in the width of the path 	<input type="checkbox"/>		
fixed the path edging securely and levelled to +/-30mm in the length of the path	<input type="checkbox"/>		
laid the sub base	<input type="checkbox"/>		
laid the gravel path to the specifications provided and straight with no deviation greater than 30mm	<input type="checkbox"/>		
maintained a clean and safe working area and has followed health and safety guidelines	<input type="checkbox"/>		
cleared work area of surplus materials and debris on completion of the job	<input type="checkbox"/>		
cleaned all tools and equipment ready for re-use	<input type="checkbox"/>		

Assignment passed? Yes / No

Assessor signature _____

Date _____

To complete task A you must prepare an area, set out and lay block paving in a half lap pattern to the tolerances outlined in the marking criteria.

This task is designed to be completed in pairs but you must carry out every aspect of the task. The completed paved area should be a minimum of 2m² in size. If you are working in a pair see the diagram (Figure 1) provided for the specification. Where you are completing the task individually the area should be 1.2 m².

You must choose the personal protective equipment (PPE), tools and materials that you will need to do the job from a selection provided which may include items which are not required.

You should be familiar with the performance criteria before commencement of the task but should not have a copy with you during the assessment.

You have two hours to complete this task.

You can achieve gain a pass, merit or distinction by achieving smaller tolerances (see the marking criteria).

Figure 1

Half lap pattern

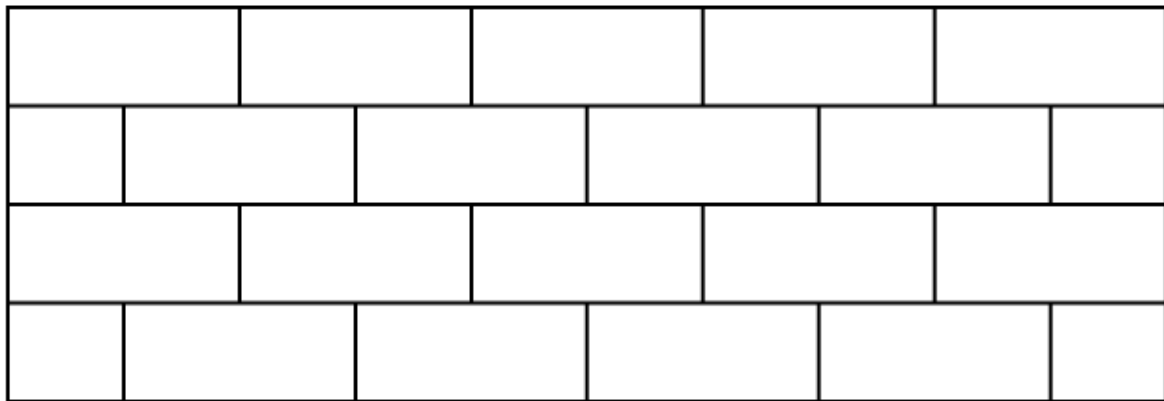

Specification

Completed paved area should be 2m² for pairs of candidates or 1.2m² for individuals.

Assignment 122 Laying block paving

Marking criteria Task A



Candidate name _____

Assessor name _____

Centre name _____

To pass the assignment, candidates are required to complete each task to the minimum standard indicated below. This task can be achieved at Pass, Merit or Distinction. All criteria for each grade must be achieved to claim that grade.

The candidate has:	Pass	Merit	Distinction
identified the personal protective equipment (PPE) appropriate to setting out and laying an area of block paving	<input type="checkbox"/>		
identified the materials required to complete the task	<input type="checkbox"/>		
identified the tools and equipment required to complete the task	<input type="checkbox"/>		
used personal protective equipment (PPE) appropriate to the task	<input type="checkbox"/>		
selected tools, equipment and materials required to prepare the area	<input type="checkbox"/>		
selected the tools and equipment and materials required to set out and lay paving	<input type="checkbox"/>		
demonstrated safe setup of the work area	<input type="checkbox"/>		
laid the bedding material correctly with no gaps bigger than	<input type="checkbox"/> 30mm	<input type="checkbox"/> 20mm	<input type="checkbox"/> 10mm
set out the correct pattern and laid pavours correctly. The pattern was maintained within	<input type="checkbox"/> 30mm	<input type="checkbox"/> 20mm	<input type="checkbox"/> 15mm
cut pavours correctly	<input type="checkbox"/> +/- 3mm	<input type="checkbox"/> +/- 3mm	<input type="checkbox"/> +/- 3mm
compacted pavours correctly	<input type="checkbox"/> +/- 30mm	<input type="checkbox"/> +/- 20mm	<input type="checkbox"/> +/- 10mm
set out the paving square to a tolerance of	<input type="checkbox"/> +/- 50mm	<input type="checkbox"/> +/- 30mm	<input type="checkbox"/> +/- 15mm
brushed in sand filler correctly	<input type="checkbox"/>		
maintained a clean and safe working area and has followed health and safety guidelines	<input type="checkbox"/>		
cleared work area of surplus materials and debris on completion of the job	<input type="checkbox"/>		
cleaned all tools and equipment ready for re-use	<input type="checkbox"/>		

Assignment passed? **Final Grade** Pass/Merit/Distinction

Assessor signature _____

Date _____

Assignment 123

Laying underground domestic drainage



Task A

Lay underground drainage

This task is designed to be completed in pairs with each candidate responsible for completion of every aspect of the task. Where you are completing the task on your own you will need to cover all aspects.

To complete task A you must prepare, lay and test a length of domestic drain to the specification in the diagram (Figure 1) provided.

You must work safely at all times in line with the centre's Health and Safety guidelines. If the assessor believes that you are doing anything which may harm yourself or others they will stop your assessment.

You have two hours to complete this task.

This task may be achieved at pass, merit or distinction according to the tolerances in the grading criteria.

Figure 1

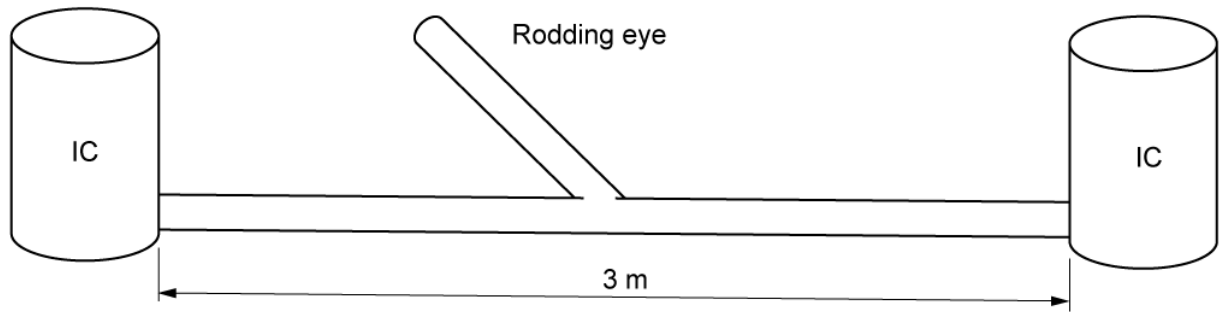

Specification

The drain should be laid to a fall of 65mm in 3m length.

Assignment 123

Laying underground domestic drainage



Marking criteria

Task A

Candidate name _____

Assessor name _____

Centre name _____

To pass the assignment, candidates are required to complete each task to the minimum standard indicated below. This task can be achieved at pass, merit or distinction and the tolerances below should be used to determine the grade achieved. All criteria for each grade must be achieved to claim that grade.

The candidate has:	Pass	Merit	Distinction
identified the personal protective equipment (PPE) appropriate to setting out and laying drainage	<input type="checkbox"/>		
identified the components required	<input type="checkbox"/>		
identified the tools and equipment required to complete the task	<input type="checkbox"/>		
used personal protective equipment (PPE) appropriate to the task	<input type="checkbox"/>		
selected the tools and equipment required to complete the task	<input type="checkbox"/>		
selected materials and components	<input type="checkbox"/>		
demonstrated safe setup of the work area	<input type="checkbox"/>		
laid the bedding material correctly	<input type="checkbox"/>		
set out the drain between two manholes to 3m	<input type="checkbox"/> +/- 50mm	<input type="checkbox"/> +/- 30mm	<input type="checkbox"/> +/- 20mm
cut pipes correctly if required pipe ends were smoothed to allow collars to be inserted	<input type="checkbox"/> some rough edges	<input type="checkbox"/> some rough edges	<input type="checkbox"/> no rough edges
jointed pipes correctly	<input type="checkbox"/>		
placed the rodding eye within the middle third of the run to a tolerance of	<input type="checkbox"/> +/- 100mm	<input type="checkbox"/> +/-30mm	<input type="checkbox"/> no deviation
laid pipes to line- no deviation greater than	<input type="checkbox"/> +/-50mm	<input type="checkbox"/> +/-30mm	<input type="checkbox"/> +/-15mm
tested the system for water tightness and the system passed the test	<input type="checkbox"/>		
maintained a clean and safe working area and has followed health and safety guidelines	<input type="checkbox"/>		
cleared the work area of surplus materials and debris on completion of the job	<input type="checkbox"/>		
cleaned all tools and equipment ready for re-use	<input type="checkbox"/>		

Assignment passed? **Final Grade** Pass/Merit/Distinction

Assessor signature _____

Date _____

Candidate name _____

Assessor name _____

Centre name _____

Using the tools and materials provided, you must cast a concrete item to the specifications provided. In addition you must answer one question correctly.

You must

- prepare a work area and choose your mould
- ensure that you wear appropriate PPE and maintain a clean and safe working environment at all times
- select the tools, equipment and materials required to complete the task
- set up the mould
- clean the mould
- oil the mould
- mix the concrete by hand to a suitable consistency
- fill the mould
- compact the concrete to remove air bubbles
- leave it to set
- ease and strip the mould
- clean all tools and equipment ready for re-use

You must work safely at all times in line within the centre’s health and safety guidelines. If the assessor believes that you are doing anything which may harm yourself or others they will stop your assessment.

You have two hours to complete this task.

This task may be achieved at pass only.

Candidate answer record

No.	Answer	Achieved
1		

Candidate name _____

Assessor name _____

Centre name _____

To pass the assignment, candidates are required to complete each task to the minimum standard indicated below. This task can be achieved at pass only.

The candidate has:	Pass	Merit	Distinction
identified the personal protective equipment (PPE) appropriate to setting up a mould and mixing and casting concrete	<input type="checkbox"/>		
identified the materials required to set up and cast the item	<input type="checkbox"/>		
identified the tools and equipment required to cast the item	<input type="checkbox"/>		
used personal protective equipment (PPE) appropriate to the task	<input type="checkbox"/>		
selected the tools and equipment required to mix and place concrete	<input type="checkbox"/>		
demonstrated safe setup of the work area	<input type="checkbox"/>		
selected and prepared the mould to receive concrete	<input type="checkbox"/>		
mixed concrete by hand	<input type="checkbox"/>		
cast and finished the item produced to the specifications provided	<input type="checkbox"/>		
released the concrete when set	<input type="checkbox"/>		
maintained a clean and safe working area and has followed the centre's health and safety guidelines	<input type="checkbox"/>		
cleared the work area of surplus materials and debris on completion of the job	<input type="checkbox"/>		
cleaned all tools and equipment ready for re-use	<input type="checkbox"/>		
correctly answered question	<input type="checkbox"/>		

Assignment passed? Yes/No

Assessor signature _____

Date _____

3 Appendices

Unit feedback and forward planning form

Feedback and action planning form

Unit and task number	
Candidate name	

Task reference	Unit feedback		

Task reference	Action plan	Target date	Achievement date

Useful contacts

UK candidates
General qualification information

E:
candidatesupport@cityandguilds.com

International candidates
General qualification information

E: intcg@cityandguilds.com

Centres
Exam entries, Registrations/enrolment, Certificates, Invoices, Missing or late exam materials, Nominal roll reports, Results

E: centresupport@cityandguilds.com

Single subject qualifications
Exam entries, Results, Certification, Missing or late exam materials, Incorrect exam papers, Forms request (BB, results entry), Exam date and time change

E: singlesubjects@cityandguilds.com

International awards
Results, Entries, Enrolments, Invoices, Missing or late exam materials, Nominal roll reports

E: intops@cityandguilds.com

Walled Garden
Re-issue of password or username, Technical problems, Entries, Results, e-assessment, Navigation, User/menu option, Problems

E: walledgarden@cityandguilds.com

Employer
Employer solutions, Mapping, Accreditation, Development Skills, Consultancy

E: business_unit@cityandguilds.com

Publications
Logbooks, Centre documents, Forms, Free literature

If you have a complaint, or any suggestions for improvement about any of the services that City & Guilds provides, email:
feedbackandcomplaints@cityandguilds.com

Published by City & Guilds
1 Giltspur Street
London
EC1A 9DD
www.cityandguilds.com

City & Guilds is a registered charity
established to promote education
and training