

# 6710-13 Level 1 Diploma in Wall and Floor Tiling

July 2013 Version 1.0

PRACTICAL TASK MANUAL

# Contents

<b>Candidate details</b>	<b>1</b>
<b>Unit assessment overview</b>	<b>2</b>
Practical task completion record	2
<b>Instructions to candidates</b>	<b>4</b>
<b>Unit 126 Preparing tiles for fixing to wall and floor installations</b>	<b>5</b>
Task 1 Prepare tiles and accessories for fixing	5
Task 2 Cut tiles and accessories prior to fixing	7
<b>Unit 127 Apply and fix tiling materials to wall and floor tiling installations</b>	<b>9</b>
Task 1 Apply materials and fix tiles to background surfaces	9
Task 2 Apply finishing materials to tiled surfaces	11
<b>Unit 128 Set out tiling components</b>	<b>13</b>
Task 1 Prepare tiling materials and set out ready for tiling	13
<b>Unit 129 Mix Tiling Materials</b>	<b>15</b>
Task 1 Prepare, gauge and mix materials	15
<b>Unit 130 Handle and Store Tiling Materials and Accessories</b>	<b>17</b>
Task 1 Handle and store tiling materials and accessories	17
<b>Drawings and diagrams</b>	<b>18</b>
Units 126, 127 and 128 Figure 1 – Wall area to be tiled	18
Units 126, 127 and 128 Figure 2 – Floor area to be tiled	19
<b>Appendices</b>	<b>20</b>
Appendix 1 – Risk assessment form	20
Appendix 2 – Resource checklist for candidates	22

## Candidate details



This *Practical task manual* is a record of your achievement in practical assessments. You must keep it in good condition and it must be stored in a safe place by your Assessor.

Please fill in all of your details before you carry out any assessments.

### Candidate Details

Surname		Forename(s)	
---------	--	-------------	--

City & Guilds enrolment number	
--------------------------------	--

### Centre Details

Name		Centre No	
------	--	-----------	--

I understand the requirements of the qualification and that all the work towards the assessments must be my own.

<b>Candidate signature</b> (please print)	
----------------------------------------------	--

<b>Assessor name</b> (please print)		Signed	
----------------------------------------	--	--------	--

Date	
------	--

# Unit assessment overview

## Practical task completion record

### Unit 126 Preparing tiles for fixing to wall and floor installations

Task	Grade for task
1 Prepare tiles and accessories for fixing	P / X
2 Cut tiles and accessories prior to fixing	P / X
End of unit knowledge test	P / X

Assessor signature and date:

Candidates must pass all tasks, and the end of unit knowledge test, for this unit to achieve a pass grade overall.

**Overall grade**

### Unit 127 Apply and fix tiling materials to wall and floor tiling installations

Task	Grade for task
1 Apply materials and fix tiles to background surfaces	P / M / D / X
2 Apply finishing materials to tiled surfaces	P / X
End of unit knowledge test	P / X

Assessor signature and date:

All tasks must be passed for the unit to be achieved. The overall grade will be the same as the single graded task in this unit.

**Overall grade**

### Unit 128 Set out tiling components

Task	Grade for task
1 Prepare tiling materials and set out ready for tiling	P / M / D / X
End of unit knowledge test	P / X

Assessor signature and date:

All tasks must be passed for the unit to be achieved. The overall grade will be the same as the single graded task in this unit.

**Overall grade**

## Unit 129 Mix Tiling Materials

Task	Grade for task
1 Prepare, gauge and mix materials	P / X
End of unit knowledge test	P / X

Assessor signature and date:  	Candidates must pass the task and the end of unit knowledge test for this unit to achieve a pass grade overall.  <p style="text-align: right;"><b>Overall grade</b></p>	<input style="width: 100%; height: 40px;" type="text"/>
--------------------------------------	-------------------------------------------------------------------------------------------------------------------------------------------------------------------------------	---------------------------------------------------------

## Unit 130 Handle and Store Tiling Materials and Accessories

Task	Grade for task
1 Handle and store tiling materials and accessories	P / X
End of unit knowledge test	P / X

Assessor signature and date:  	Candidates must pass the task and the end of unit knowledge test for this unit to achieve a pass grade overall.  <p style="text-align: right;"><b>Overall grade</b></p>	<input style="width: 100%; height: 40px;" type="text"/>
--------------------------------------	-------------------------------------------------------------------------------------------------------------------------------------------------------------------------------	---------------------------------------------------------

### Authenticity and IQA/QC sampling

The assessor's signature on individual tasks will be taken as assurance that the judgements recorded are made on authentic candidate work produced under appropriate conditions. Please complete the declaration below to confirm this is the case.

I confirm that all tasks were conducted under conditions designed to assure the authenticity of the candidate's work, and am satisfied that, to the best of my knowledge, the work assessed was solely that of the candidate. I have judged all assessments against the relevant assessment and grading criteria and award the candidate the unit grades as calculated above.	
Assessor signature	Date
*IQA signature and date	*QC signature and date

\*IQA and QC signatures attest to the evidence available on the recorded date(s).

# Instructions to candidates

## About this document

This *Practical task manual* contains all of the practical assessment for 6710-13 Level 1 Diploma in Wall and Floor Tiling.

## Practical tasks

These tasks let you show your practical skills and are usually graded pass, merit or distinction – a few are pass only. These tasks will be assessed by your assessor watching how you carry out the tasks and checking your final pieces of work.

Before you carry out the task you will be told how it will be assessed and you should read the observation checklist at the end of each task so you know what you need to do to get each grade.

You can ask your assessor for help in understanding the task instructions, but all of the work must be your own.

## Health and safety

You must use safe working practices at all times.

You are responsible for your own safety and the safety of others. If you behave in an unsafe way, you will be stopped and given a warning. If you do not meet all of the Health and Safety requirements, the assessment will be stopped. Your assessor will not be able to let you try the task again until they are sure you can work safely.

## Time considerations

Each task shows how long it is likely to take. This is for guidance and so you can plan your work. If you have a good reason for needing more time you must explain this to your assessor as soon as possible so they can decide whether you can have more time.

## Security

Where an assignment is taken over more than one session, all documentation, paperwork and work products must be labelled carefully with your name and kept securely at the centre. Your assessor will give you directions about how to leave your work.

## Opportunities to repeat tasks

The tasks are 'end tests' so you will only be asked to take the assessment when you have had the chance to do all of the learning and practice you need. You will be able to try the whole task again if you do not pass, but you will not be able to take the assessment again just to try to get a better grade.

## Feedback

As well as telling you the result for the task your assessor will give you feedback. They will give you a feedback sheet with details of what you could do to improve, and also what you did well in. This will help you to prepare for other assessments or to retake the assessment if you need to.

# Unit 126 Preparing tiles for fixing to wall and floor installations

## Task 1 Prepare tiles and accessories for fixing

<b>Expected time</b>	3 hours
<b>Task instructions</b>	<p>In this task, for the areas shown in Figures 1 and 2, you will</p> <ul style="list-style-type: none"> <li>• prepare tiles and accessories for fixing to walls and floors</li> <li>• work to given specification and drawings, following manufacturers' instructions</li> <li>• complete Resource Checklist to identify hand and power tools, materials/accessories and quantities, and PPE required</li> <li>• ensure there are sufficient materials to complete the task, to include 10% for waste</li> <li>• inspect tiles for irregularities.</li> </ul> <p>Note: You will be using hand tools (not mechanical equipment) for <u>cutting holes</u> in tiles for this Task.</p> <p>You are expected to follow the centre's risk assessment throughout the task, to leave the work area tidy, and to follow relevant environmental and health and safety regulations.</p>
<b>Diagrams</b>	<p>Figure 1 – Wall area to be tiled – page 18</p> <p>Figure 2 – Floor area to be tiled – page 19</p>

### Observation checklist

AC	The candidate has	Pass	Merit	Distinction
2.1	<p>read, signed and agreed Risk Assessment for cutting tiles and accessories</p> <p>followed Risk Assessment throughout assessment</p>	<input type="checkbox"/>		
2.2	<p>interpreted instructions for preparing tiling and accessories for fixing:</p> <ul style="list-style-type: none"> <li>• manufacturers' instructions eg adhesive classifications</li> <li>• batch identification numbers</li> </ul>	<input type="checkbox"/>		
2.3	<p>completed Resource Checklist for materials and accessories required for Task to prepare tiles and accessories for fixing</p> <p>identified location of materials and accessories</p> <p>selected items, using checklist</p> <p>inspected tiles for irregularities of size, shape, shade, batch, and damage.</p>	<input type="checkbox"/>		
2.4	<p>completed Resource Checklist for PPE to prepare tiles and accessories for fixing</p> <p>selected items, using checklist</p>	<input type="checkbox"/>		

AC	The candidate has	Pass	Merit	Distinction
2.5	completed Resource Checklist for hand and power tools to prepare tiles and accessories for fixing selected items, using checklist	<input type="checkbox"/>		

Task grading rules		Task grade:
To award a <b>pass</b> : every activity in the checklist must be successfully achieved.		
Assessor	Signature & Date	



## Unit 126 Preparing tiles for fixing to wall and floor installations

### Task 2 Cut tiles and accessories prior to fixing

<b>Expected time</b>	1 hour
<b>Task instructions</b>	<p>In this task you will</p> <ul style="list-style-type: none"> <li>• calculate wall and floor tiles required for Figures 1 and 2, allowing 10% waste</li> <li>• protect surrounding areas</li> <li>• mark and cut first wall tiles and accessories, and then floor tiles, using a variety of cuts.</li> </ul> <p>You are expected to follow the centre's risk assessment throughout the task, to leave the work area tidy and to follow relevant environmental and health and safety regulations.</p>
<b>Diagrams</b>	<p>Figure 1 – Wall area to be tiled – page 18</p> <p>Figure 2 – Floor area to be tiled – page 19</p>

#### Observation checklist

AC	The candidate has	Pass	Merit	Distinction
4.1	<p>read, signed and agreed Risk assessment for cutting tiles and accessories</p> <p>followed Risk Assessment throughout assessment</p>	<input type="checkbox"/>		
4.2	<p>calculated required number of tiles and accessories required from instructions, including 10% waste, for:</p> <ul style="list-style-type: none"> <li>• wall tiles</li> <li>• floor tiles</li> <li>• accessories</li> </ul> <p>calculations included:</p> <ul style="list-style-type: none"> <li>• area in square metres</li> <li>• amount of tiles per metre square for wall and floor tiles.</li> </ul>	<input type="checkbox"/>		
4.3	<p>protected work and surrounding areas from damage in accordance with organisational requirements</p>	<input type="checkbox"/>		

AC	The candidate has	Pass	Merit	Distinction
4.4	<p>cut and prepared tiles and accessories in accordance with instructions (Figures 1 and 2)</p> <ul style="list-style-type: none"> <li>• marked and cut wall tiles</li> <li>• marked and cut floor tiles</li> <li>• cuts: straight</li> <li>• mitring trims: internal angles</li> <li>• trims: external angles</li> </ul> <p>using</p> <ul style="list-style-type: none"> <li>• manual cutting</li> </ul> <p>and</p> <ul style="list-style-type: none"> <li>• wet cutting</li> </ul>	<input type="checkbox"/>		
4.5	<p>followed current environmental and health and safety regulations</p> <ul style="list-style-type: none"> <li>• ensured work area left tidy on completion of task</li> <li>• disposed of waste in designated containers/ skips</li> <li>• recycled materials in designated storage areas.</li> </ul>	<input type="checkbox"/>		

Task grading rules		Task grade:
To award a <b>pass</b> : every activity in the checklist must be successfully achieved.		
Assessor	Signature & Date	

## Unit 127 Apply and fix tiling materials to wall and floor tiling installations

### Task 1 Apply materials and fix tiles to background surfaces

<b>Expected time</b>	12 hours
<b>Task instructions</b>	<p>In this task, for the areas shown in Figures 1 and 2, you will:</p> <ul style="list-style-type: none"> <li>• check and prime wall and floor backgrounds</li> <li>• apply wall and floor adhesives</li> <li>• position and fix tiles and accessories to             <ul style="list-style-type: none"> <li>• a wall area, no less than 4m<sup>2</sup></li> <li>• a floor area no less than 2m<sup>2</sup></li> </ul> </li> </ul> <p>using the tools, equipment, materials and PPE you have identified in your Resource Checklist.</p> <p>You are expected to follow the centre's risk assessment throughout the task, to leave the work area tidy, and to follow relevant environmental and health and safety regulations.</p> <p>Grading for this Task is based on your ability to cut efficiently, keeping waste to a minimum and the accuracy of your cutting.</p>
<b>Diagrams</b>	<p>Figure 1 – Wall area to be tiled – page 18</p> <p>Figure 2 – Floor area to be tiled – page 19</p>

### Observation checklist

AC	The candidate has	Pass	Merit	Distinction
3.1	<p>applied materials using safe mixing procedures to backgrounds to given instructions:</p> <ul style="list-style-type: none"> <li>• primer</li> <li>• ready mixed adhesive</li> <li>• powdered adhesives</li> </ul> <p>to 3 out of the 4 following backgrounds:</p> <ul style="list-style-type: none"> <li>• plaster board</li> <li>• plaster</li> <li>• backer board</li> <li>• render <b>or</b> sand and lime.</li> </ul>	<input type="checkbox"/>		
3.2	protected work and surrounding areas from damage in accordance with organisational requirements	<input type="checkbox"/>		
5.1	positioned and fixed tiles and accessories			
5.1	<ul style="list-style-type: none"> <li>• fixed battens to wall</li> </ul>	<input type="checkbox"/> Battens ± 3mm	<input type="checkbox"/> Battens ± 2mm	<input type="checkbox"/> Battens ± 1mm

AC	The candidate has	Pass	Merit	Distinction
5.1	<ul style="list-style-type: none"> <li>checked accuracy of spirit level and straight edge and</li> <li>used tools spirit level, straight edge and measuring tape</li> </ul>	<input type="checkbox"/>		
5.1	<ul style="list-style-type: none"> <li>positioned and fixed tiles to backgrounds - plumb</li> </ul>	<input type="checkbox"/> Tiles ± 3mm	<input type="checkbox"/> Tiles ± 2mm	<input type="checkbox"/> Tiles ± 1mm
5.1	<ul style="list-style-type: none"> <li>positioned and fixed tiles to backgrounds - level</li> </ul>	<input type="checkbox"/> Tiles ± 3mm level	<input type="checkbox"/> Tiles ± 2mm level	<input type="checkbox"/> Tiles ± 1mm level
5.1	<ul style="list-style-type: none"> <li>joint sizes – wall</li> </ul>	<input type="checkbox"/> 3/5 points correct	<input type="checkbox"/> 4/5 points correct	<input type="checkbox"/> 5/5 points correct
	<ul style="list-style-type: none"> <li>joint sizes - floor</li> </ul>	<input type="checkbox"/> 3/5 points correct	<input type="checkbox"/> 4/5 points correct	<input type="checkbox"/> 5/5 points correct
	<ul style="list-style-type: none"> <li>positioned and fixed tile edging trims to cill, soffit and reveals</li> </ul>	<input type="checkbox"/>		
3.3 / 5.2	<p>followed current environmental and relevant health and safety regulations relating to applying materials and fixing tiles, including centre's Risk Assessment</p> <ul style="list-style-type: none"> <li>followed centre's Risk Assessment throughout task</li> <li>ensured work area left tidy on completion of task</li> <li>disposed of waste in designated containers/ skips</li> <li>recycled materials in designated storage areas.</li> </ul>	<input type="checkbox"/>		

Task grading rules		Task grade:
To award a <b>pass</b> : every activity in the checklist must be successfully achieved.		
To award a <b>merit</b> : in addition to the above, all <b>5</b> graded activities in the checklist must be achieved to <b>at least</b> a merit standard.		
To award a <b>distinction</b> : in addition to both of the above, all <b>5</b> graded activities in the checklist must be achieved to a distinction standard.		
Assessor	Signature & Date	

# Unit 127 Apply and fix tiling materials to wall and floor tiling installations

## Task 2 Apply finishing materials to tiled surfaces

<b>Expected time</b>	3 hours
<b>Task instructions</b>	<p>In this task, for the areas shown in Figures 1 and 2, you will</p> <ul style="list-style-type: none"> <li>• select grout and mix following manufacturers' technical information</li> <li>• apply grout to industry standards</li> <li>• leave a 6mm movement gap on the internal angle</li> <li>• use a tile edging trim on the external angle</li> <li>• apply sealant to internal movement joint and</li> <li>• apply sealant to the internal angle 2 linear metres in length.</li> </ul> <p>You are expected to follow the centre's risk assessment throughout the task, to leave the work area tidy, and to follow relevant environmental and health and safety regulations.</p>
<b>Diagrams</b>	<p>Figure 1 – Wall area to be tiled – page 18</p> <p>Figure 2 – Floor area to be tiled – page 19</p>

### Observation checklist

AC	The candidate has	Pass	Merit	Distinction
7.1	ensured joints were clean and free from contamination	<input type="checkbox"/>		
7.1	<p>selected grout, calculated grout quantity and</p> <p>applied grout to ceramic tiled wall and floor surfaces</p> <ul style="list-style-type: none"> <li>• joints to be full flat and even with no drags or runs</li> <li>• free from holes</li> <li>• all work to be buffed on completion</li> </ul>	<input type="checkbox"/>		
7.1	used grouting tools to achieve required finish	<input type="checkbox"/>		
7.2	<p>applied sealant to internal movement joints on tiled surfaces</p> <ul style="list-style-type: none"> <li>• sealant joint full and even with no drag marks minimum 2 linear metres.</li> </ul>	<input type="checkbox"/>		

AC	The candidate has	Pass	Merit	Distinction
7.3	<p>followed current environmental and relevant health and safety regulations relating to applying materials and fixing tiles, including centre's Risk Assessment</p> <ul style="list-style-type: none"> <li>• followed centre's Risk Assessment throughout task</li> <li>• ensured work area left tidy on completion of task</li> <li>• disposed of waste in designated containers/ skips</li> <li>• recycled materials in designated storage areas.</li> </ul>	<input type="checkbox"/>		

Task grading rules		Task grade:
To award a <b>pass</b> : every activity in the checklist must be successfully achieved.		
Assessor	Signature & Date	

## Unit 128 Set out tiling components

### Task 1 Prepare tiling materials and set out ready for tiling

<b>Expected time</b>	3 hours
<b>Task instructions</b>	<p>In this task, for the area shown in Figures 1 and 2, you will:</p> <ul style="list-style-type: none"> <li>• select tools and equipment, materials and PPE required to prepare tiling materials and set out, using your completed Resource Checklist</li> <li>• prepare areas prior to work</li> <li>• set out areas to receive tiling materials</li> <li>• mark out a gauge rod</li> <li>• establish datum point</li> <li>• transfer datum line</li> <li>• set out wall and floor tiles using centring method.</li> </ul> <p>You are expected to follow the centre's Risk Assessment throughout the task, to leave the work area tidy and to follow relevant environmental and relevant health and safety regulations.</p> <p>Grading for this Task will be based on the accuracy of your work.</p>
<b>Diagrams</b>	<p>Figure 1 – Wall area to be tiled – page 18</p> <p>Figure 2 – Floor area to be tiled – page 19</p>

#### Observation checklist

AC	The candidate has	Pass	Merit	Distinction
2.1	read, signed and agreed Risk Assessment for setting out tiling components followed Risk Assessment throughout assessment	<input type="checkbox"/>		
2.2	identified type, size, quantity and position of materials in accordance with manufacturers' instructions using completed Resource Checklist	<input type="checkbox"/>		
2.3	selected materials, tools and equipment to be used to carry out work	<input type="checkbox"/>		
2.4	prepared area and surrounding areas prior to work	<input type="checkbox"/>		

AC	The candidate has	Pass	Merit	Distinction
4.1	set out wall and floor area specified, accurately in accordance with specification and work instructions: <ul style="list-style-type: none"> <li>checked accuracy of spirit level(s) and straight edge</li> <li>marked out a gauge rod</li> <li>established datum point</li> <li>used 3:4:5 method or builder's square for floor</li> <li>checked dimensions</li> </ul>	<input type="checkbox"/>		
4.1	<ul style="list-style-type: none"> <li>transferred datum line</li> </ul>	<input type="checkbox"/> ± 3mm	<input type="checkbox"/> ± 2mm	<input type="checkbox"/> ± 1mm
4.1	<ul style="list-style-type: none"> <li>established and transferred vertical plumb line</li> </ul>	<input type="checkbox"/> ± 3mm	<input type="checkbox"/> ± 2mm	<input type="checkbox"/> ± 1mm
4.1	<ul style="list-style-type: none"> <li>used centring method</li> </ul>	<input type="checkbox"/> ± 3mm	<input type="checkbox"/> ± 2mm	<input type="checkbox"/> ± 1mm
4.2	left work area clean and tidy on completion of work	<input type="checkbox"/>		
4.3	followed current environmental and relevant health and safety regulations relating to applying materials and fixing tiles <ul style="list-style-type: none"> <li>ensured work area left tidy on completion of task</li> <li>disposed of waste in designated containers/ skips</li> <li>recycled materials in designated storage areas.</li> </ul>	<input type="checkbox"/>		

Task grading rules		Task grade:
To award a <b>pass</b> : every activity in the checklist must be successfully achieved.		
To award a <b>merit</b> : in addition to the above, all <b>3</b> graded activities in the checklist must be achieved to <b>at least</b> a merit standard.		
To award a <b>distinction</b> : in addition to both of the above, all <b>3</b> graded activities in the checklist must be achieved to a distinction standard.		
Assessor	Signature & Date	



# Unit 129 Mix Tiling Materials

## Task 1 Prepare, gauge and mix materials

<b>Expected time</b>	2 hours
<b>Task instructions</b>	<p>In this task, you will:</p> <ul style="list-style-type: none"> <li>calculate the amount of powdered adhesive required, for an area 4m<sup>2</sup>, using a 6mm trowel</li> <li>mix adhesive according to manufacturer's specifications</li> </ul> <p>using the tools, equipment, materials and PPE you have identified in your Resource Checklist.</p> <p>You are expected to follow the centre's Risk Assessment throughout the task, to leave the work area tidy and to follow relevant environmental and relevant health and safety regulations.</p>
<b>Diagrams</b>	n/a

### Observation checklist

AC	The candidate has	Pass	Merit	Distinction
2.1	<p>read, signed and agreed Risk Assessment for preparing, gauging and mixing materials</p> <p>followed Risk Assessment throughout assessment</p> <p>read manufacturers' instructions, and followed throughout assessment.</p>	<input type="checkbox"/>		
2.2	<p>calculated the quantity of powdered adhesive in accordance with manufacturers' instructions for:</p> <ul style="list-style-type: none"> <li>an area 4m<sup>2</sup>, using a 6mm trowel</li> </ul>	<input type="checkbox"/>		
2.3	<p>selected materials and equipment required to carry out work.</p> <p>completed Resource Checklist for materials and accessories required for task</p> <p>identified location of materials and accessories required</p> <p>selected items from checklist</p>	<input type="checkbox"/>		
4.1	located a suitable working area, clean and fit for purpose	<input type="checkbox"/>		
4.2	<p>used correct method to gauge and mix adhesive according to manufacturers' instructions</p> <ul style="list-style-type: none"> <li>used correct tools and equipment</li> <li>thoroughly mixed material and ensured of workable consistency</li> <li>followed manufacturer's guidelines</li> </ul>	<input type="checkbox"/>		

AC	The candidate has	Pass	Merit	Distinction
4.3	<p>left work area clean and tidy on completion of work</p> <p>returned all equipment and tools clean and fit for purpose</p>	<input type="checkbox"/>		
2.4 and 4.5	<p>followed current environmental and relevant health and safety regulations relating to mixing tiling materials</p> <ul style="list-style-type: none"> <li>• hazards</li> <li>• debris</li> <li>• dust and other obstacles</li> <li>• PUWER.</li> </ul>	<input type="checkbox"/>		
4.4	<p>disposed of materials in accordance with Waste Management Act legislation</p> <ul style="list-style-type: none"> <li>• correctly disposed of waste materials</li> <li>• recycled materials where possible.</li> </ul>	<input type="checkbox"/>		

Task grading rules		Task grade:
To award a <b>pass</b> : every activity in the checklist must be successfully achieved.		
Assessor	Signature & Date	

## Unit 130 Handle and Store Tiling Materials and Accessories

### Task 1 Handle and store tiling materials and accessories

<b>Expected time</b>	3 hours
<b>Task instructions</b>	<p>In this task, you will:</p> <ul style="list-style-type: none"> <li>source, check and load materials according to a delivery note</li> <li>store materials.</li> </ul> <p>You are expected to follow the centre's risk assessment throughout the task, to leave the work area tidy, and to follow relevant environmental and health and safety regulations.</p>
<b>Diagrams</b>	n/a

#### Observation checklist

AC	The candidate has	Pass	Merit	Distinction
2.1	read, signed and agreed Risk Assessment for handling and storing tiling materials and accessories followed Risk Assessment throughout assessment	<input type="checkbox"/>		
2.2/	selected materials and accessories from delivery note	<input type="checkbox"/>		
8.1	checked materials comply with delivery note	<input type="checkbox"/>		
2.3	identified any defects in materials and accessories <ul style="list-style-type: none"> <li>damaged materials</li> <li>different codes/batch numbers</li> <li>use by date</li> </ul>	<input type="checkbox"/>		
4.1 / 4.2	used safe manual handling techniques to lift and move materials and accessories to designated area <ul style="list-style-type: none"> <li>used kinetic lifting techniques</li> <li>used lifting aids as required</li> <li>ensured the route or area is safe and clear</li> <li>used correct personal protective equipment (PPE)</li> </ul>	<input type="checkbox"/>		
6.1	stored materials and accessories in accordance with organisational procedures	<input type="checkbox"/>		

Task grading rules		Task grade:
To award a <b>pass</b> : every activity in the checklist must be successfully achieved.		
Assessor	Signature & Date	

**Drawings and diagrams**  
**Units 126, 127 and 128**

**Figure 1 – Wall area to be tiled**

**Specification**

Drawing is not to scale.

This is an **example** of what the area to be tiled will look like.

Wall area minimum:

equivalent to 4m<sup>2</sup>

with one internal angle one external angle and one window

window: minimum size 500mm by 500mm

dimensions: to fit in bay size 2400mm x 2400mm

Tile sizes: 150mm x 150mm

Tile joint sizes: 2mm

Movement joint: soft mastic

Backgrounds: any of plaster, plaster board, backer board

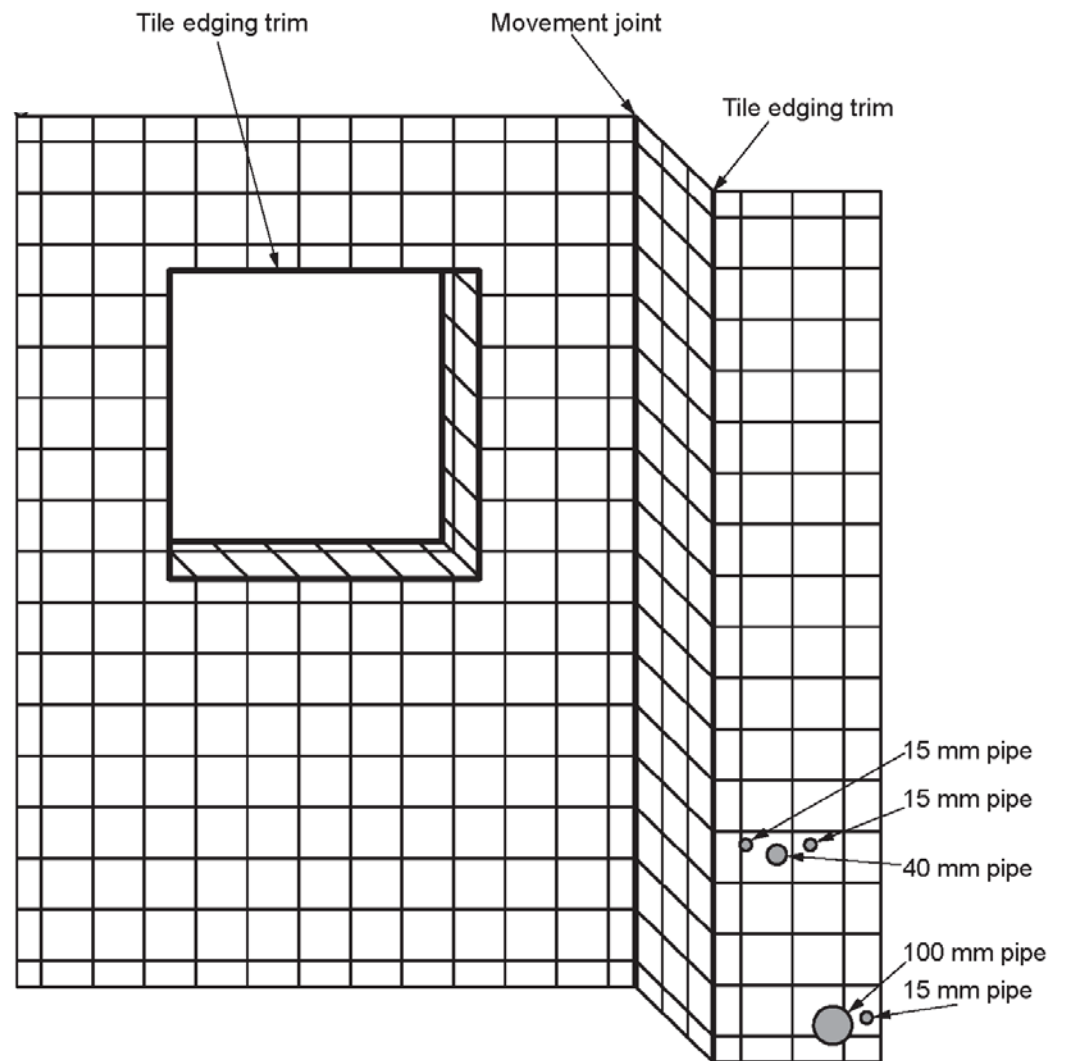

Figure 2 – Floor area to be tiled

**Specification**

Drawing is **not** to scale.

This is an **example** of what the area to be tiled will look like.

Floor area minimum: equivalent to 2m<sup>2</sup>

Tile sizes: 300mm x 300mm

Tile joint sizes: 4mm

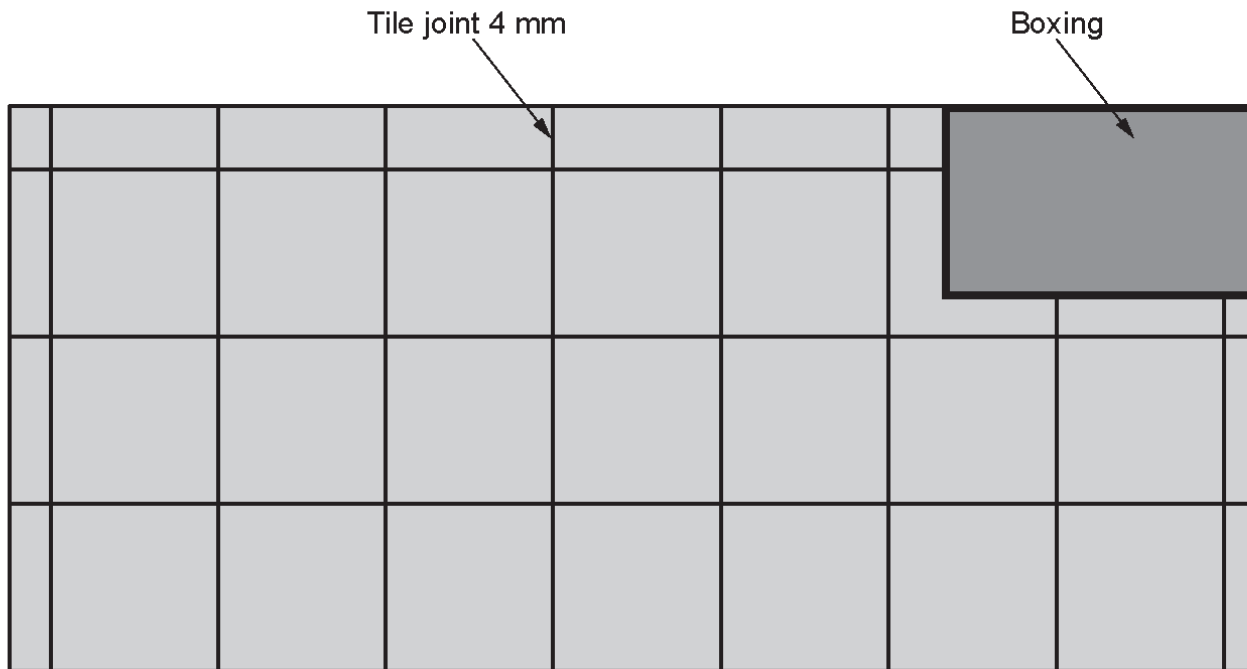

Floor plan

# Appendices

## Appendix 1 – Risk assessment form

<b>Unit / Task no</b>		<b>Area or activity assessed:</b>
<b>Assessment date</b>		
<b>Persons who may be affected by the activity (ie are at risk)</b>	<b>OPERATIVES:</b>  <b>OTHERS:</b>	

**SECTION 1: Identify Hazards** - Consider the activity or work area and identify if any of the hazards listed below are significant (tick the boxes that apply).

1.	Fall of person (from work at height)		6.	Lighting levels		11.	Use of portable tools / equipment		16.	Radiation sources		21.	Condition of Buildings & glazing	
2.	Fall of objects		7.	Heating & ventilation		12.	Fixed machinery or lifting equipment		17.	Work with lasers		22.	Occupational stress	
3.	Slips, Trips & Housekeeping		8.	Layout , storage, space, obstructions		13.	Noise or Vibration		18.	Hazardous fumes, chemicals, dust		23.	Violence to staff / verbal assault	
4.	Manual handling operations		9.	Welfare facilities		14.	Fire hazards & flammable material		19.	Hazardous biological agent		24.	Lone working / work out of hours	
5.	Abrasive wheels		10.	Electrical Equipment		15.	Fieldtrips / field work		20.	Food preparation areas		25.	Other(s) - specify	

**SECTION 2: Risk Controls** - For each hazard identified in Section 1, complete Section 2.

Hazard No.	Hazard Description	Existing controls to reduce risk	Risk Level (tick one)			Further action needed to reduce risks <i>(provide timescales and initials of person responsible)</i>
			High	Med	Low	
1.						
<b>Name of Writer</b>		<b>SIGNED</b>			Number of continuation sheets used:	
<b>Review date</b>						

**Risk Level:** High = very likely, Medium = possible, Low = unlikely

# Health and Safety Risk Assessments – Continuation Sheet

Unit / Task no	
Continuation sheet number:	1

## SECTION 2 continued: Risk Controls

Hazard No.	Hazard Description	Existing controls to reduce risk	Risk Level (tick one)			Further action needed to reduce risks  <i>(provide timescales and initials of person responsible for action)</i>
			High	Med	Low	
2.						
3.						
4.						
5.						

# Appendixes

## Appendix 2 – Resource checklist for candidates



<b>Candidate name and date</b>	
--------------------------------	--

Minimum requirements are:

TOOLS/EQUIPMENT	Unit number			
	Tick items required and quantity			
	126 Quantity	127 Quantity	128 Quantity	129 Quantity
MANUAL TILE CUTTING MACHINE				
WET SAW				
PANEL SAW				
JUNIOR HACKSAW				
HACKSAW				
MITRE BLOCK				
SERRATING TROWEL 6MM				
SERRATING TROWEL 10MM				
GAUGING TROWEL OR BUCKET TROWEL				
TILE NIPPERS (SNIPS/MOSAIC CUTTERS)				
TILING BREAKERS (APORTO CUTTERS)				
SEALANT GUN				
SQUEEGEE/GROUT FLOAT				
LOCHBOY AND HAMMER				
CLAW HAMMER				
PIN HAMMER				
TILE FILE				
TILE SCRIBE				
RETRACTABLE UTILITY KNIFE				
SCISSORS				
CARBORUNDUM STONE				
600mm SPIRIT LEVEL				
1000mm SPIRIT LEVEL				
BUILDERS SQUARE/SET SQUARE				
STRAIGHT EDGE OR FEATHER EDGE				
TAPE MEASURE / RULER				
HAND BRUSH				
PENCILS				
MARKER PENS				
PENCIL SHARPENER				
SPONGES				
WASH BOY AND SPONGE FLOAT				
GROUT FLOAT				
CLEANING CLOTHS / POLISHING RAGS				
BUCKETS FOR MIXING PRODUCTS				
CHALK LINE				



TOOLS/EQUIPMENT	Unit number			
	Tick items required and quantity			
	126 Quantity	127 Quantity	128 Quantity	129 Quantity
STRING LINE				
MIXING PADDLE AND DRILL				
FOLDING SQUARE				
WALL SCRAPER				
FLOOR SCRAPER				
CORDLESS DRILL/DRIVER				
SCREWDRIVERS				
RUBBER Mallet				
ROLLER AND TRAY				
DIAMOND FILES				
DUST PAN AND BRUSH				
SOFT BRISTLED BRUSH				
BATTENS				
CLEAN WATER				
CALCULATOR				
MOVING AND HANDLING AIDS				
DUST SHEETS				

MATERIALS/ACCESSORIES	Unit number			
	Tick items required and quantity			
	126 Quantity	127 Quantity	128 Quantity	129 Quantity
WALL TILE ADHESIVE				
FLOOR TILE ADHESIVE (POWDER AND READY MIXED)				
WALL GROUT				
FLOOR GROUT				
SEALANT				
NAILS/SCREWS				
PROTECTIVE SHEET MATERIALS				
TAPE TO SECURE MATERIALS				
TIMBER FOR USE AS GAUGE ROD				
PRIMERS				
WALL TILES				
FLOOR TILES				
TILE TRIMS				
SPACER PEGS				

PPE	Unit number			
	Tick items required and quantity			
	126 Quantity	127 Quantity	128 Quantity	129 Quantity
KNEE PADS				
SAFETY GLASSES / EYE PROTECTION				
SAFETY GLOVES				
BARRIER CREAM				
OVERALLS				
DUST MASK				
EAR PROTECTION				
HARD HAT (CENTRE'S DISCRETION)				
SAFETY FOOTWEAR / BOOTS				
LUMBAR SUPPORT				
HIGH VISIBILITY VEST				

**Use for any calculations eg tiles, adhesive**

---

**Published by City & Guilds**  
**1 Giltspur Street**  
**London**  
**EC1A 9DD**  
**T +44 (0)844 543 0000**  
**F +44 (0)20 7294 2413**  
**www.cityandguilds.com**

**City & Guilds is a registered charity  
established to promote education  
and training**

#### **About City & Guilds**

As the UK's leading vocational education organisation, City & Guilds is leading the talent revolution by inspiring people to unlock their potential and develop their skills. We offer over 500 qualifications across 28 industries through 8500 centres worldwide and award around two million certificates every year. City & Guilds is recognised and respected by employers across the world as a sign of quality and exceptional training.

#### **City & Guilds Group**

The City & Guilds Group operates from three major hubs: London (servicing Europe, the Caribbean and Americas), Johannesburg (servicing Africa), and Singapore (servicing Asia, Australia and New Zealand). The Group also includes the Institute of Leadership & Management (management and leadership qualifications), City & Guilds Land Based Services (land-based qualifications), the Centre for Skills Development (CSD works to improve the policy and practice of vocational education and training worldwide) and Learning Assistant (an online e-portfolio).

#### **Copyright**

The content of this document is, unless otherwise indicated, © The City and Guilds of London Institute and may not be copied, reproduced or distributed without prior written consent. However, approved City & Guilds centres and candidates studying for City & Guilds qualifications may photocopy this document free of charge and/or include a PDF version of it on centre intranets on the following conditions:

- centre staff may copy the material only for the purpose of teaching candidates working towards a City & Guilds qualification, or for internal administration purposes
- candidates may copy the material only for their own use when working towards a City & Guilds qualification

The *Standard Copying Conditions* (see the City & Guilds website) also apply.

Published by City & Guilds, a registered charity established to promote education and training

Every effort has been made to ensure that the information contained in this publication is true and correct at the time of going to press. However, City & Guilds' products and services are subject to continuous development and improvement and the right is reserved to change products and services from time to time. City & Guilds cannot accept liability for loss or damage arising from the use of information in this publication.