

# 6805-33 Diploma in Bricklaying at SCQF Level 6

September 2014 Version 1.3

PRACTICAL TASK MANUAL

# Contents

<b>Task manual amendments</b>	<b>1</b>
<b>Candidate details</b>	<b>2</b>
<b>Unit assessment overview</b>	<b>3</b>
Practical task completion record	3
<b>Instructions to candidates</b>	<b>5</b>
<b>Unit 302 Repair and maintain masonry structures</b>	<b>6</b>
Task 1 Remove and renew masonry	6
<b>Unit 303 Constructing radial and battered brickwork</b>	<b>8</b>
Task 1 Build a segmental arch with a battered buttress	8
Task 2 Build curved brickwork	10
<b>Unit 304 Carrying out decorative and reinforced brickwork</b>	<b>12</b>
Task 1 Build decorative reinforced brickwork	12
Task 2 Build an obtuse quoin	15
<b>Unit 305 Constructing fireplaces and chimneys</b>	<b>17</b>
Task 1 Build a block wall with flue liners	17
Task 2 Build a chimney stack	19
<b>Drawings and diagrams</b>	<b>22</b>
Unit 303 Constructing radial and battered brickwork	22
Unit 304 Carrying out decorative and reinforced brickwork	24
Unit 305 Constructing fireplaces and chimneys	26
<b>Resource checklists</b>	<b>28</b>
Unit 302 Task 1 Resource Checklist	28
Unit 305 Task 1 Resource Checklist	30
Unit 305 Task 2 Resource Checklist	32

# Task manual amendments

## Amendments in version 1.1

Page 12      Unit 304, Task 1: Added additional check to observation checklist for inclusion of horizontal reinforcement.

## Amendments in version 1.2

Pages 22-27      Amendments made to the diagrams and task times for the following assessments: 303 Task 1&2, 304 Task 1&2, 305 Task 2.

## Amendments in version 1.3

P22      changed Diagram

## Candidate details



This *Practical task manual* is a record of your achievement in practical assessments. You must keep it in good condition and it must be stored in a safe place by your Assessor.

Please fill in all of your details before you carry out any assessments.

### Candidate Details

Surname		Forename(s)	
---------	--	-------------	--

City & Guilds enrolment number	
--------------------------------	--

### Centre Details

Name		Centre No	
------	--	-----------	--

I understand the requirements of the qualification and that all the work towards the assessments must be my own.

<b>Candidate signature</b> (please print)	
--	--

<b>Assessor name</b> (please print)		Signed	
--	--	--------	--

Date	
------	--

# Unit assessment overview

## Practical task completion record

### To be completed by Assessor:

For each task, the points for each grade are  
 Pass = 1, Merit = 2, and Distinction = 3 points.

Conversion chart	
Average	Overall Grade
1 – 1.5	Pass
1.6 – 2.5	Merit
2.6 – 3	Distinction

### Unit 302 Repair and maintain masonry structures

Task	Grade for task
1 Remove and renew masonry	P / M / D / X
End of unit knowledge test	P / X

All tasks must be passed for the unit to be achieved.

Assessor signature and date:

The overall grade will be the same as the single graded task in this unit.

**Overall grade**

### Unit 303 Constructing radial and battered brickwork

Task	Grade for task <sup>†</sup>	Points (graded tasks)
1 Build a segmental arch with a battered buttress	P / M / D / X	
2 Build curved brickwork	P / M / D / X	
End of unit knowledge test	P / X	
All tasks must be passed for the unit to be achieved.		<b>Total</b>
Assessor signature and date:		For graded tasks, divide total points by total number of graded tasks
		÷ 2
		Average =
		<b>Overall grade</b> (see conversion chart)

## Unit 304 Carrying out decorative and reinforced brickwork

Task	Grade for task†	Points (graded tasks)
1 Build decorative reinforced brickwork	P / M / D / X	
2 Build an obtuse quoin	P / M / D / X	
End of unit knowledge test	P / X	
All tasks must be passed for the unit to be achieved.		<b>Total</b>
Assessor signature and date:	For graded tasks, divide total points by total number of graded tasks	÷ 2
		Average =
		<b>Overall grade</b>
		(see conversion chart)

## Unit 305 Constructing fireplaces and chimneys

Task	Grade for task†	Points (graded tasks)
1 Build a block wall with flue liners	P / M / D / X	
2 Build a chimney stack	P / M / D / X	
End of unit knowledge test	P / X	
All tasks must be passed for the unit to be achieved.		<b>Total</b>
Assessor signature and date:	For graded tasks, divide total points by total number of graded tasks	÷ 2
		Average =
		<b>Overall grade</b>
		(see conversion chart)

## Authenticity and IQA/QC sampling

The assessor's signature on individual tasks will be taken as assurance that the judgements recorded are made on authentic candidate work produced under appropriate conditions. Please complete the declaration below to confirm this is the case.

I confirm that all tasks were conducted under conditions designed to assure the authenticity of the candidate's work, and am satisfied that, to the best of my knowledge, the work assessed was solely that of the candidate.	
I have judged all assessments against the relevant assessment and grading criteria and award the candidate the unit grades as calculated above.	
Assessor signature	Date
*IQA signature and date	*QC signature and date

\*IQA and QC signatures attest to the evidence available on the recorded date(s).

# Instructions to candidates

## About this document

This *Practical task manual* contains all of the practical assessment for 6805-33 Diploma in Bricklaying at SCQF Level 6.

## Practical tasks

These tasks let you show your practical skills and are usually graded pass, merit or distinction – a few are pass only. These tasks will be assessed by your assessor watching how you carry out the tasks and checking your final pieces of work.

Before you carry out the task you will be told how it will be assessed and you should read the observation checklist at the end of each task so you know what you need to do to get each grade.

You can ask your assessor for help in understanding the task instructions, but all of the work must be your own.

## Health and safety

You must use safe working practices at all times.

You are responsible for your own safety and the safety of others. If you behave in an unsafe way, you will be stopped and given a warning. If you do not meet all of the Health and Safety requirements, the assessment will be stopped. Your assessor will not be able to let you try the task again until they are sure you can work safely.

## Time considerations

Each task shows how long it is likely to take. This is for guidance and so you can plan your work. If you have a good reason for needing more time you must explain this to your assessor as soon as possible so they can decide whether you can have more time.

## Security

Where an assignment is taken over more than one session, all documentation, paperwork and work products must be labelled carefully with your name and kept securely at the centre. Your assessor will give you directions about how to leave your work.

## Opportunities to repeat tasks

The tasks are 'end tests' so you will only be asked to take the assessment when you have had the chance to do all of the learning and practice you need. You will be able to try the whole task again if you do not pass, but you will not be able to take the assessment again just to try to get a better grade.

## Feedback

As well as telling you the result for the task your assessor will give you feedback. They will give you a feedback sheet with details of what you could do to improve, and also what you did well in. This will help you to prepare for other assessments or to retake the assessment if you need to.

# Unit 302 Repair and maintain masonry structures

## Task 1 Remove and renew masonry

<b>Expected time</b>	6 hours
<b>Task instructions</b>	<ul style="list-style-type: none"> <li>Identify defective masonry.</li> <li>Identify defective mortar joints.</li> <li>Complete the <i>Unit 302 Task 1 Resource Checklist</i>.</li> <li>Remove and replace damaged masonry.</li> <li>Remove and replace defective mortar joints.</li> </ul>

### Observation checklist

AC	The candidate has	Pass	Merit	Distinction
3.1	identified defective and damaged masonry materials	<input type="checkbox"/>		
3.2	completed <i>Unit 302 Task 1 Resource Checklist</i>	<input type="checkbox"/>		
3.3	<b>brick replacement</b>			
	removed defective brickwork without damage to surrounding masonry	<input type="checkbox"/>		
	replaced defective brickwork without damage to surrounding masonry	<input type="checkbox"/>		
	replaced brick to line	<input type="checkbox"/> ± 5 mm	<input type="checkbox"/> ± 3 mm	<input type="checkbox"/> ± 1 mm
	maintained plumb of replacement brick	<input type="checkbox"/> ± 5 mm	<input type="checkbox"/> ± 3 mm	<input type="checkbox"/> ± 1 mm
	maintained range of replacement brick	<input type="checkbox"/> ± 5 mm	<input type="checkbox"/> ± 3 mm	<input type="checkbox"/> ± 1 mm
	ensured all brickwork jointing is full and complete	<input type="checkbox"/>		
	ensured face of wall is free of smudging and staining	<input type="checkbox"/>		
	<b>block replacement</b>			
	removed defective blockwork without damage to surrounding masonry	<input type="checkbox"/>		
	cut blockwork to the required length	<input type="checkbox"/>		
	replaced defective blockwork without damage to surrounding masonry	<input type="checkbox"/>		
	replaced block to line	<input type="checkbox"/> ± 6 mm	<input type="checkbox"/> ± 4 mm	<input type="checkbox"/> ± 2 mm
	maintained plumb of replacement block	<input type="checkbox"/> ± 6 mm	<input type="checkbox"/> ± 4 mm	<input type="checkbox"/> ± 2 mm



AC	The candidate has	Pass	Merit	Distinction
3.3	maintained range of replacement block	<input type="checkbox"/> ± 6 mm	<input type="checkbox"/> ± 4 mm	<input type="checkbox"/> ± 2 mm
	ensured all blockwork jointing is full and complete	<input type="checkbox"/>		
	ensured face of wall is free of smudging and staining	<input type="checkbox"/>		
	<b>re-pointing</b>			
	raked out mortar joints to the uniform depth	<input type="checkbox"/>		
	raked out mortar joints to the full width	<input type="checkbox"/>		
	pointed new brickwork/blockwork to match specification	<input type="checkbox"/>		
	ensured all jointing is full and complete	<input type="checkbox"/>		
	ensured face of wall is free of smudging and staining	<input type="checkbox"/>		
3.4, 4.1, 4.2, 4.3, 4.4	maintained a clean, safe and tidy work area and protected the surrounding area immediately adjacent to the work	<input type="checkbox"/>		
	cleaned, checked and stored tools, equipment and materials after use	<input type="checkbox"/>		
	disposed of waste materials in line with legislation	<input type="checkbox"/>		
	used tools, equipment and materials in a safe manner	<input type="checkbox"/>		
	used and maintained PPE as appropriate	<input type="checkbox"/>		
	followed current environmental and health and safety legislation.	<input type="checkbox"/>		

Task grading rules		Task grade:
To award a <b>pass</b> : every activity in the checklist must be successfully achieved.		
To award a <b>merit</b> : in addition to the above, all <b>6</b> graded activities in the checklist must be achieved to <b>at least</b> a merit standard.		
To award a <b>distinction</b> : in addition to both of the above, all <b>6</b> graded activities in the checklist must be achieved to a distinction standard.		
Assessor	Signature & Date	

# Unit 303 Constructing radial and battered brickwork

## Task 1 Build a segmental arch with a battered buttress

<b>Expected time</b>	12 hours
<b>Task instructions</b>	<ul style="list-style-type: none"> <li>• Read the drawings and specifications.</li> <li>• Complete a method statement and risk assessment.</li> <li>• Set out brickwork.</li> <li>• Position materials.</li> <li>• Build segmental arch with a battered buttress.</li> <li>• Keep a clean work area.</li> <li>• Work safely at all times.</li> </ul>
<b>Diagrams</b>	See page 22

### Observation checklist

AC	The candidate has	Pass	Merit	Distinction
2.1, 8.1	read drawing and specifications, and confirmed understanding of the task	<input type="checkbox"/>		
2.2, 8.2	completed a method statement	<input type="checkbox"/>		
2.3, 8.3	completed a risk assessment	<input type="checkbox"/>		
2.4	produced template for voussoirs	<input type="checkbox"/>		
2.5	provided temporary support for arch	<input type="checkbox"/>		
2.6	cut voussoirs consistently	<input type="checkbox"/>		
2.7, 2.8	maintained overall gauge of wall	<input type="checkbox"/> ± 6 mm	<input type="checkbox"/> ± 4 mm	<input type="checkbox"/> ± 2 mm
	maintained overall level of wall	<input type="checkbox"/> ± 6 mm	<input type="checkbox"/> ± 4 mm	<input type="checkbox"/> ± 2 mm
	built brickwork plumb (point A)	<input type="checkbox"/> ± 6 mm	<input type="checkbox"/> ± 4 mm	<input type="checkbox"/> ± 2 mm
	built brickwork plumb (point B)	<input type="checkbox"/> ± 6 mm	<input type="checkbox"/> ± 4 mm	<input type="checkbox"/> ± 2 mm
	built brickwork plumb (point C)	<input type="checkbox"/> ± 6 mm	<input type="checkbox"/> ± 4 mm	<input type="checkbox"/> ± 2 mm
	built brickwork plumb (point E)	<input type="checkbox"/> ± 6 mm	<input type="checkbox"/> ± 4 mm	<input type="checkbox"/> ± 2 mm
	maintained range to wall	<input type="checkbox"/> ± 6 mm	<input type="checkbox"/> ± 4 mm	<input type="checkbox"/> ± 2 mm
	produced full and complete joints to wall	<input type="checkbox"/>		
	produced full and complete joints to arch	<input type="checkbox"/>		

AC	The candidate has	Pass	Merit	Distinction
2.7, 2.8	ensured correct angle to skewbacks	<input type="checkbox"/>		
	ensured neat cuts around arch	<input type="checkbox"/>		
	ensured arch soffit is smooth and clean	<input type="checkbox"/>		
8.4	used template to build buttress	<input type="checkbox"/>		
8.5	cut components for buttress	<input type="checkbox"/>		
8.6	maintained overall gauge of buttress	<input type="checkbox"/> ± 6 mm	<input type="checkbox"/> ± 4 mm	<input type="checkbox"/> ± 2 mm
	built brickwork plumb (point D)	<input type="checkbox"/> ± 6 mm	<input type="checkbox"/> ± 4 mm	<input type="checkbox"/> ± 2 mm
	produced full and complete joints to buttress	<input type="checkbox"/>		
	maintained face plane of buttress	<input type="checkbox"/> ± 6 mm	<input type="checkbox"/> ± 4 mm	<input type="checkbox"/> ± 2 mm
	ensured buttress square to wall	<input type="checkbox"/> ± 5 mm	<input type="checkbox"/> ± 3 mm	<input type="checkbox"/> ± 1 mm
2.9, 8.7	followed current environmental and health and safety legislation	<input type="checkbox"/>		
	used tools, equipment and materials in a safe manner	<input type="checkbox"/>		
	used and maintained PPE as appropriate	<input type="checkbox"/>		
	maintained a clean and safe working area	<input type="checkbox"/>		
	cleaned and returned all tools and equipment once the task is complete.	<input type="checkbox"/>		

Task grading rules	Task grade:
To award a <b>pass</b> : every activity in the checklist must be successfully achieved.	
To award a <b>merit</b> : in addition to the above, <b>7</b> out of <b>11</b> graded activities in the checklist must be achieved to <b>at least</b> a merit standard.	
To award a <b>distinction</b> : <b>7</b> out of <b>11</b> graded activities in the checklist must be achieved to <b>at least</b> a distinction standard, and <b>4</b> of the remaining graded activities must be achieved to <b>at least</b> a merit standard.	
<b>Assessor Signature &amp; Date</b>	

# Unit 303 Constructing radial and battered brickwork

## Task 2 Build curved brickwork

<b>Expected time</b>	8 ½ hours
<b>Task instructions</b>	<ul style="list-style-type: none"> <li>• Read the drawings and specifications.</li> <li>• Complete a method statement and risk assessment.</li> <li>• Set out curved brickwork.</li> <li>• Position materials.</li> <li>• Use a trammel rod to build curved brickwork.</li> <li>• Use a template to build curved brickwork.</li> <li>• Keep a clean work area.</li> <li>• Work safely at all times.</li> </ul>
<b>Diagrams</b>	See page 23

### Observation checklist

AC	The candidate has	Pass	Merit	Distinction
4.1, 6.1	read drawing and specifications, and confirmed understanding of the task	<input type="checkbox"/>		
4.2, 6.2	completed method statement	<input type="checkbox"/>		
4.3, 6.3	completed risk assessment	<input type="checkbox"/>		
4.4, 4.5, 4.6, 4.7, 6.4, 6.5, 6.6, 6.7	<b>TRAMMEL METHOD</b>			
	maintained overall gauge	<input type="checkbox"/> ± 5 mm	<input type="checkbox"/> ± 3 mm	<input type="checkbox"/> ± 1 mm
	maintained level over 1.0 m	<input type="checkbox"/> ± 6 mm	<input type="checkbox"/> ± 4 mm	<input type="checkbox"/> ± 2 mm
	maintained plumb	<input type="checkbox"/> ± 6 mm	<input type="checkbox"/> ± 4 mm	<input type="checkbox"/> ± 2 mm
	maintained vertical perpend	<input type="checkbox"/> ± 6 mm	<input type="checkbox"/> ± 4 mm	<input type="checkbox"/> ± 2 mm
	ensured face/rear joints full and complete	<input type="checkbox"/>		
	produced half round joint finish to face	<input type="checkbox"/>		
	produced flush joint to rear	<input type="checkbox"/>		
	used trammel to build <input type="checkbox"/> convex or <input type="checkbox"/> concave brickwork curved on plan	<input type="checkbox"/>		
	cut components for brickwork curved on plan	<input type="checkbox"/>		
	maintained accuracy of curve	<input type="checkbox"/>		

AC	The candidate has	Pass	Merit	Distinction
4.4, 4.5, 4.6, 4.7, 6.4, 6.5, 6.6, 6.7	<b>TEMPLATE METHOD</b>			
	maintained overall gauge	<input type="checkbox"/> ± 5 mm	<input type="checkbox"/> ± 3 mm	<input type="checkbox"/> ± 1 mm
	maintained level over 1.0 m	<input type="checkbox"/> ± 6 mm	<input type="checkbox"/> ± 4 mm	<input type="checkbox"/> ± 2 mm
	maintained plumb	<input type="checkbox"/> ± 6 mm	<input type="checkbox"/> ± 4 mm	<input type="checkbox"/> ± 2 mm
	maintained vertical perpend	<input type="checkbox"/> ± 6 mm	<input type="checkbox"/> ± 4 mm	<input type="checkbox"/> ± 2 mm
	ensured face/rear joints full and complete	<input type="checkbox"/>		
	produced half round joint finish to face	<input type="checkbox"/>		
	produced flush joint to rear	<input type="checkbox"/>		
	used template to build <input type="checkbox"/> convex or <input type="checkbox"/> concave brickwork curved on plan	<input type="checkbox"/>		
	cut components for brickwork curved on plan	<input type="checkbox"/>		
	maintained accuracy of curve	<input type="checkbox"/>		
	4.8, 6.8	followed current environmental and health and safety legislation	<input type="checkbox"/>	
used tools, equipment and materials in a safe manner		<input type="checkbox"/>		
used and maintained PPE as appropriate		<input type="checkbox"/>		
maintained a clean and safe working area		<input type="checkbox"/>		
cleaned and returned all tools and equipment once the task is complete.		<input type="checkbox"/>		

Task grading rules	Task grade:
To award a <b>pass</b> : every activity in the checklist must be successfully achieved.	
To award a <b>merit</b> : in addition to the above, <b>6</b> out of <b>8</b> graded activities in the checklist must be achieved to <b>at least</b> a merit standard.	
To award a <b>distinction</b> : <b>6</b> out of <b>8</b> graded activities in the checklist must be achieved to <b>at least</b> a distinction standard, and <b>2</b> of the remaining graded activities must be achieved to <b>at least</b> a merit standard.	
<b>Assessor Signature &amp; Date</b>	

# Unit 304 Carrying out decorative and reinforced brickwork

## Task 1 Build decorative reinforced brickwork

<b>Expected time</b>	12 ½ hours
<b>Task instructions</b>	<ul style="list-style-type: none"> <li>• Read the drawings and specifications.</li> <li>• Complete a method statement and risk assessment.</li> <li>• Position materials.</li> <li>• Set out brickwork.</li> <li>• Build decorative reinforced brickwork.</li> <li>• Keep a clean work area.</li> <li>• Work safely at all times.</li> </ul>
<b>Diagrams</b>	See page 24

### Observation checklist

AC	The candidate has	Pass	Merit	Distinction
2.1, 6.1	read drawing and specifications, and confirmed understanding of the task	<input type="checkbox"/>		
2.2, 6.2	completed a method statement	<input type="checkbox"/>		
2.3, 6.3	completed a risk assessment	<input type="checkbox"/>		
2.4, 6.4	ensured neat cuts	<input type="checkbox"/>		
	ensured matching cuts are uniform	<input type="checkbox"/>		
2.5, 6.5	set out length of wall (course 1)	<input type="checkbox"/> ± 6 mm	<input type="checkbox"/> ± 4 mm	<input type="checkbox"/> ± 2 mm
	set out first course to square	<input type="checkbox"/> ± 5 mm	<input type="checkbox"/> ± 3 mm	<input type="checkbox"/> ± 1 mm
	built vertical reinforcement into courses 1 to 5	<input type="checkbox"/>		
	built horizontal reinforcement (every three courses) into courses 5 to 12	<input type="checkbox"/>		
	projected 6 stretcher bricks at courses 2 and 4	<input type="checkbox"/> ± 5 mm	<input type="checkbox"/> ± 3 mm	<input type="checkbox"/> ± 1 mm
	maintained overall gauge	<input type="checkbox"/> ± 6 mm	<input type="checkbox"/> ± 4 mm	<input type="checkbox"/> ± 2 mm
	maintained level at course 4	<input type="checkbox"/> ± 6 mm	<input type="checkbox"/> ± 4 mm	<input type="checkbox"/> ± 2 mm
	maintained level at course 18	<input type="checkbox"/> ± 6 mm	<input type="checkbox"/> ± 4 mm	<input type="checkbox"/> ± 2 mm
	built brickwork plumb (area A – 1 point)	<input type="checkbox"/> ± 6 mm	<input type="checkbox"/> ± 4 mm	<input type="checkbox"/> ± 2 mm

AC	The candidate has	Pass	Merit	Distinction
2.5, 6.5	built brickwork plumb (area B – 1 point)	<input type="checkbox"/> ± 6 mm	<input type="checkbox"/> ± 4 mm	<input type="checkbox"/> ± 2 mm
	built brickwork plumb (area C – 1 point)	<input type="checkbox"/> ± 6 mm	<input type="checkbox"/> ± 4 mm	<input type="checkbox"/> ± 2 mm
	built brickwork plumb (area D – 1 point)	<input type="checkbox"/> ± 6 mm	<input type="checkbox"/> ± 4 mm	<input type="checkbox"/> ± 2 mm
	built brickwork plumb (area E – 1 point)	<input type="checkbox"/> ± 6 mm	<input type="checkbox"/> ± 4 mm	<input type="checkbox"/> ± 2 mm
	built brickwork plumb (area F – 1 point)	<input type="checkbox"/> ± 6 mm	<input type="checkbox"/> ± 4 mm	<input type="checkbox"/> ± 2 mm
	built the 3 stacked projections plumb	<input type="checkbox"/> ± 6 mm	<input type="checkbox"/> ± 4 mm	<input type="checkbox"/> ± 2 mm
	ranged face work of front elevation	<input type="checkbox"/> ± 6 mm	<input type="checkbox"/> ± 4 mm	<input type="checkbox"/> ± 2 mm
	ensured the top arris of courses 5, 6, 7 and 8 are free from mortar droppings	<input type="checkbox"/>		
	incorporated a uniform dental course indent	<input type="checkbox"/> ± 5 mm	<input type="checkbox"/> ± 3 mm	<input type="checkbox"/> ± 1 mm
	set out dog tothing course correctly	<input type="checkbox"/>		
	evenly stepped-in brickwork (courses 6, 7, 8 and 9)	<input type="checkbox"/>		
	evenly stepped-out brickwork (courses 12, 13, 14 and 15)	<input type="checkbox"/>		
	finished joints as per specification, neatly and with no smudging	<input type="checkbox"/>		
2.6, 6.6	followed current environmental and relevant health and safety legislation	<input type="checkbox"/>		
	used tools, equipment and materials in a safe manner	<input type="checkbox"/>		
	used and maintained PPE as appropriate	<input type="checkbox"/>		
	maintained a clean and safe working area	<input type="checkbox"/>		
	cleaned and returned all tools and equipment once the task is complete.	<input type="checkbox"/>		

Task grading rules	Task grade:
To award a <b>pass</b> : every activity in the checklist must be successfully achieved.	
To award a <b>merit</b> : in addition to the above, <b>10</b> out of <b>15</b> graded activities in the checklist must be achieved to <b>at least</b> a merit standard.	
To award a <b>distinction</b> : <b>10</b> out of <b>15</b> graded activities in the checklist must be achieved to <b>at least</b> a distinction standard, and <b>5</b> of the remaining graded activities must be achieved to <b>at least</b> a merit standard.	
<b>Assessor Signature &amp; Date</b>	



# Unit 304 Carrying out decorative and reinforced brickwork

## Task 2 Build an obtuse quoin

<b>Expected time</b>	4 ½ hours
<b>Task instructions</b>	<ul style="list-style-type: none"> <li>• Read the drawing and specification.</li> <li>• Complete a method statement and risk assessment.</li> <li>• Position materials.</li> <li>• Set out brickwork.</li> <li>• Build decorative quoin.</li> <li>• Keep a clean work area.</li> <li>• Work safely at all times.</li> </ul>
<b>Diagrams</b>	See page 25

### Observation checklist

AC	The candidate has	Pass	Merit	Distinction
4.1	read drawing and specifications, and confirmed understanding of the task	<input type="checkbox"/>		
4.2	completed a method statement	<input type="checkbox"/>		
4.3	completed a risk assessment	<input type="checkbox"/>		
4.5	ensured neat and uniform cuts	<input type="checkbox"/>		
4.4, 4.6	set out length of wall (course 1)	<input type="checkbox"/> ± 5 mm	<input type="checkbox"/> ± 3 mm	<input type="checkbox"/> ± 1 mm
	marked and set 45° angle accurately on course 1	<input type="checkbox"/> ± 5 mm	<input type="checkbox"/> ± 3 mm	<input type="checkbox"/> ± 1 mm
	maintained correct bond	<input type="checkbox"/>		
	maintained overall gauge	<input type="checkbox"/> ± 5 mm	<input type="checkbox"/> ± 3 mm	<input type="checkbox"/> ± 1 mm
	maintained overall level of wall	<input type="checkbox"/> ± 5 mm	<input type="checkbox"/> ± 3 mm	<input type="checkbox"/> ± 1 mm
	built brickwork plumb (area A – 2 points)	<input type="checkbox"/> ± 5 mm	<input type="checkbox"/> ± 3 mm	<input type="checkbox"/> ± 1 mm
	built brickwork plumb (area B – 1 point)	<input type="checkbox"/> ± 5 mm	<input type="checkbox"/> ± 3 mm	<input type="checkbox"/> ± 1 mm
	built brickwork plumb (area C – 1 point)	<input type="checkbox"/> ± 5 mm	<input type="checkbox"/> ± 3 mm	<input type="checkbox"/> ± 1 mm
	built brickwork plumb (area D – 2 points)	<input type="checkbox"/> ± 5 mm	<input type="checkbox"/> ± 3 mm	<input type="checkbox"/> ± 1 mm
	maintained range	<input type="checkbox"/> ± 5 mm	<input type="checkbox"/> ± 3 mm	<input type="checkbox"/> ± 1 mm
	maintained alignment of squint quoin	<input type="checkbox"/>		

AC	The candidate has	Pass	Merit	Distinction
	set out brick panel at 45°	<input type="checkbox"/>		
4.7	followed current environmental and relevant health and safety legislation	<input type="checkbox"/>		
	used tools, equipment and materials in a safe manner	<input type="checkbox"/>		
	used and maintained PPE as appropriate	<input type="checkbox"/>		
	maintained a clean and safe working area	<input type="checkbox"/>		
	cleaned and returned all tools and equipment once the task is complete.	<input type="checkbox"/>		

Task grading rules	Task grade:
To award a <b>pass</b> : every activity in the checklist must be successfully achieved.	
To award a <b>merit</b> : in addition to the above, <b>6</b> out of <b>9</b> graded activities in the checklist must be achieved to <b>at least</b> a merit standard.	
To award a <b>distinction</b> : <b>6</b> out of <b>9</b> graded activities in the checklist must be achieved to <b>at least</b> a distinction standard, and <b>3</b> of the remaining graded activities must be achieved to <b>at least</b> a merit standard.	
<b>Assessor Signature &amp; Date</b>	

# Unit 305 Constructing fireplaces and chimneys

## Task 1 Build a block wall with flue liners

<b>Expected time</b>	3 hours
<b>Task instructions</b>	<ul style="list-style-type: none"> <li>• Read the drawing and specification.</li> <li>• Complete a method statement and risk assessment.</li> <li>• Complete the <i>Unit 305 Task 1 Resource Checklist</i>.</li> <li>• Position materials.</li> <li>• Set out flue starter blocks and check measurements.</li> <li>• Build a block wall incorporating flue blocks.</li> <li>• Keep a clean work area.</li> <li>• Work safely at all times.</li> </ul>
<b>Diagrams</b>	See page 26

### Observation checklist

AC	The candidate has	Pass	Merit	Distinction
2.1	read drawing and specifications, and confirmed understanding of the task	<input type="checkbox"/>		
2.2, 2.4	completed a method statement	<input type="checkbox"/>		
2.3	completed a risk assessment	<input type="checkbox"/>		
2.5, 2.6. 4.2	completed <i>Unit 305 Task 1 Resource Checklist</i>	<input type="checkbox"/>		
4.3	positioned blocks and materials ready for use	<input type="checkbox"/>		
4.1	set out and built first course to correct dimensions	<input type="checkbox"/> ± 6 mm	<input type="checkbox"/> ± 4 mm	<input type="checkbox"/> ± 2 mm
4.4	prepared and safely cut materials	<input type="checkbox"/>		
4.5	built blockwork to gauge	<input type="checkbox"/> ± 6 mm	<input type="checkbox"/> ± 4 mm	<input type="checkbox"/> ± 2 mm
	built blockwork level	<input type="checkbox"/> ± 6 mm	<input type="checkbox"/> ± 4 mm	<input type="checkbox"/> ± 2 mm
	built blockwork plumb (quoin)	<input type="checkbox"/> ± 6 mm	<input type="checkbox"/> ± 4 mm	<input type="checkbox"/> ± 2 mm
	built blockwork plumb (stopped end A)	<input type="checkbox"/> ± 6 mm	<input type="checkbox"/> ± 4 mm	<input type="checkbox"/> ± 2 mm
	built blockwork plumb (stopped end B)	<input type="checkbox"/> ± 6 mm	<input type="checkbox"/> ± 4 mm	<input type="checkbox"/> ± 2 mm
	maintained range to the face elevation	<input type="checkbox"/> ± 6 mm	<input type="checkbox"/> ± 4 mm	<input type="checkbox"/> ± 2 mm
	maintained range to the end elevation	<input type="checkbox"/> ± 6 mm	<input type="checkbox"/> ± 4 mm	<input type="checkbox"/> ± 2 mm

AC	The candidate has	Pass	Merit	Distinction
4.5	inserted reinforcement in accordance with manufacturer's guidance	<input type="checkbox"/>		
	maintained a clean flue (free of excess mortar)	<input type="checkbox"/>		
	positioned flue liners correctly and in accordance with manufacturer's guidance	<input type="checkbox"/>		
2.7, 4.6	followed current environmental and relevant health and safety legislation	<input type="checkbox"/>		
	used tools, equipment and materials in a safe manner	<input type="checkbox"/>		
	used and maintained PPE as appropriate	<input type="checkbox"/>		
	maintained a clean and safe working area	<input type="checkbox"/>		
	cleaned and returned all tools and equipment once the task is complete.	<input type="checkbox"/>		

Task grading rules	Task grade:
To award a <b>pass</b> : every activity in the checklist must be successfully achieved.	
To award a <b>merit</b> : in addition to the above, <b>6</b> out of <b>8</b> graded activities in the checklist must be achieved to <b>at least</b> a merit standard.	
To award a <b>distinction</b> : <b>6</b> out of <b>8</b> graded activities in the checklist must be achieved to <b>at least</b> a distinction standard, and <b>2</b> of the remaining graded activities must be achieved to <b>at least</b> a merit standard.	
<b>Assessor Signature &amp; Date</b>	

# Unit 305 Constructing fireplaces and chimneys

## Task 2 Build a chimney stack

<b>Expected time</b>	6 ½ hours
<b>Task instructions</b>	<ul style="list-style-type: none"> <li>• Read the drawing and specification.</li> <li>• Complete a method statement and risk assessment.</li> <li>• Complete the <i>Unit 305 Task 2 Resource Checklist</i>.</li> <li>• Position materials.</li> <li>• Set out chimney stack and check measurements.</li> <li>• Build a chimney stack incorporating flue liners.</li> <li>• Keep a clean work area.</li> <li>• Work safely at all times.</li> </ul>
<b>Diagrams</b>	See page 27

### Observation checklist

AC	The candidate has	Pass	Merit	Distinction
2.1	read drawing and specifications, and confirmed understanding of the task	<input type="checkbox"/>		
2.2, 2.4	completed method statement	<input type="checkbox"/>		
2.3	completed risk assessment	<input type="checkbox"/>		
2.5, 2.6, 4.2	completed <i>Unit 305 Task 2 Resource Checklist</i>	<input type="checkbox"/>		
4.3	positioned bricks and materials ready for use	<input type="checkbox"/>		
4.1	set out and built first course to correct dimensions	<input type="checkbox"/> ± 5 mm	<input type="checkbox"/> ± 3 mm	<input type="checkbox"/> ± 1 mm
	set out and built first course square (internal)	<input type="checkbox"/> ± 5 mm	<input type="checkbox"/> ± 3 mm	<input type="checkbox"/> ± 1 mm
	set out and built first course square (external)	<input type="checkbox"/> ± 5 mm	<input type="checkbox"/> ± 3 mm	<input type="checkbox"/> ± 1 mm
4.4	prepared and safely cut materials	<input type="checkbox"/>		
4.5	maintained overall gauge	<input type="checkbox"/> ± 5 mm	<input type="checkbox"/> ± 3 mm	<input type="checkbox"/> ± 1 mm
	built brickwork level to underside of oversailing course	<input type="checkbox"/> ± 5 mm	<input type="checkbox"/> ± 3 mm	<input type="checkbox"/> ± 1 mm
	maintained 28 mm oversailing (± 3 mm)	<input type="checkbox"/>		
	built brickwork plumb (quoin A)	<input type="checkbox"/> ± 6 mm	<input type="checkbox"/> ± 4 mm	<input type="checkbox"/> ± 2 mm
	built brickwork plumb (quoin B)	<input type="checkbox"/> ± 6 mm	<input type="checkbox"/> ± 4 mm	<input type="checkbox"/> ± 2 mm

AC	The candidate has	Pass	Merit	Distinction
4.5	built brickwork plumb (quoin C)	<input type="checkbox"/> ± 6 mm	<input type="checkbox"/> ± 4 mm	<input type="checkbox"/> ± 2 mm
	built brickwork plumb (quoin D)	<input type="checkbox"/> ± 6 mm	<input type="checkbox"/> ± 4 mm	<input type="checkbox"/> ± 2 mm
	built brickwork plumb (quoin E)	<input type="checkbox"/> ± 6 mm	<input type="checkbox"/> ± 4 mm	<input type="checkbox"/> ± 2 mm
	built brickwork plumb (quoin F)	<input type="checkbox"/> ± 6 mm	<input type="checkbox"/> ± 4 mm	<input type="checkbox"/> ± 2 mm
	built brickwork plumb (quoin G)	<input type="checkbox"/> ± 6 mm	<input type="checkbox"/> ± 4 mm	<input type="checkbox"/> ± 2 mm
	built brickwork plumb (quoin H)	<input type="checkbox"/> ± 6 mm	<input type="checkbox"/> ± 4 mm	<input type="checkbox"/> ± 2 mm
	raked out mortar joints correctly to a depth of 20 mm to receive flashings	<input type="checkbox"/>		
	maintained clean face work	<input type="checkbox"/>		
	produced mortar flashing correctly	<input type="checkbox"/>		
	produced mortar fillet correctly	<input type="checkbox"/>		
	positioned chimney pot to correct level	<input type="checkbox"/>		
	maintained a clean flue (free of excess mortar)	<input type="checkbox"/>		
	positioned flue liners correctly and in accordance with manufacturer's guidance	<input type="checkbox"/>		
	produced a neat weather struck joint finish	<input type="checkbox"/>		
2.7, 4.6	followed current environmental and relevant health and safety legislation	<input type="checkbox"/>		
	used tools, equipment and materials in a safe manner	<input type="checkbox"/>		
	used and maintained PPE as appropriate	<input type="checkbox"/>		
	maintained a clean and safe working area	<input type="checkbox"/>		
	cleaned and returned all tools and equipment once the task is complete.	<input type="checkbox"/>		

Task grading rules	Task grade:
To award a <b>pass</b> : every activity in the checklist must be successfully achieved.	
To award a <b>merit</b> : in addition to the above, <b>8</b> out of <b>13</b> graded activities in the checklist must be achieved to <b>at least</b> a merit standard.	
To award a <b>distinction</b> : <b>8</b> out of <b>13</b> graded activities in the checklist must be achieved to <b>at least</b> a distinction standard, and <b>5</b> of the remaining graded activities must be achieved to <b>at least</b> a merit standard.	
<b>Assessor Signature &amp; Date</b>	

## Drawings and diagrams

### Unit 303 Constructing radial and battered brickwork

#### Task 1 Build a segmental arch with a battered buttress

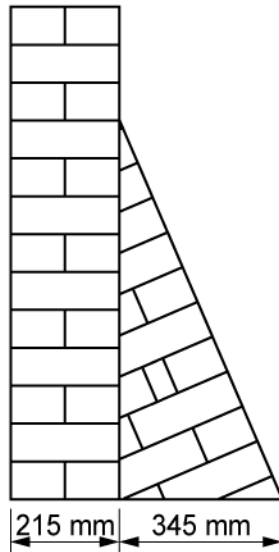

End elevation

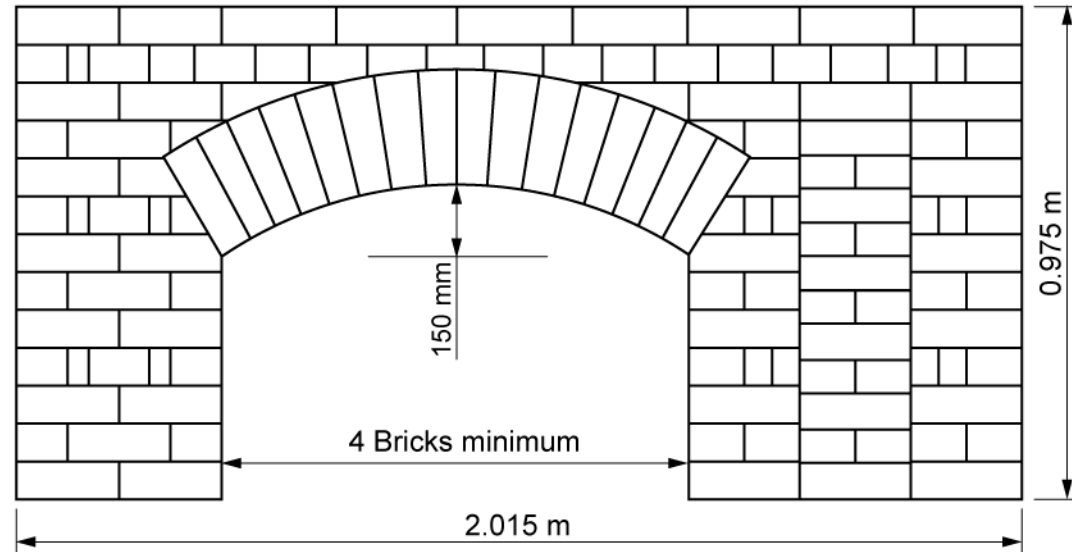

Front elevation

Specification
Arch bricks to be axed (voussoirs) Buttress to be tied in to main wall English garden wall bond to be used
Joint finish
<ul style="list-style-type: none"> <li>• Face brickwork to be half round joint finish</li> <li>• Rear of wall to be left flush from trowel</li> </ul>

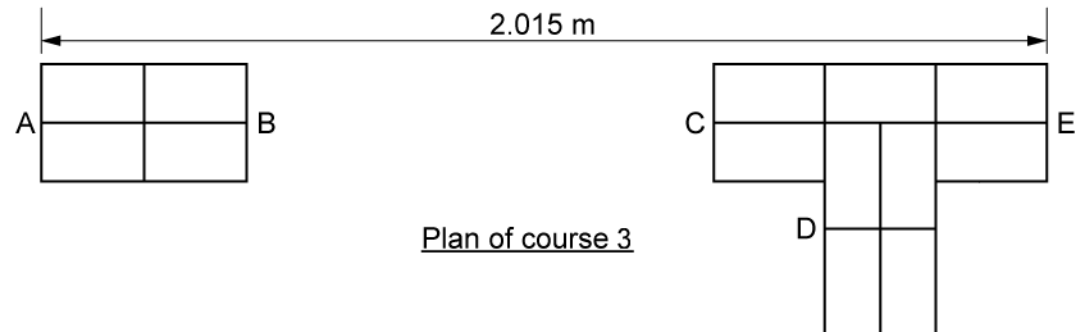

Plan of course 3



# Drawings and diagrams

## Unit 303 Constructing radial and battered brickwork

### Task 2 Build curved brickwork

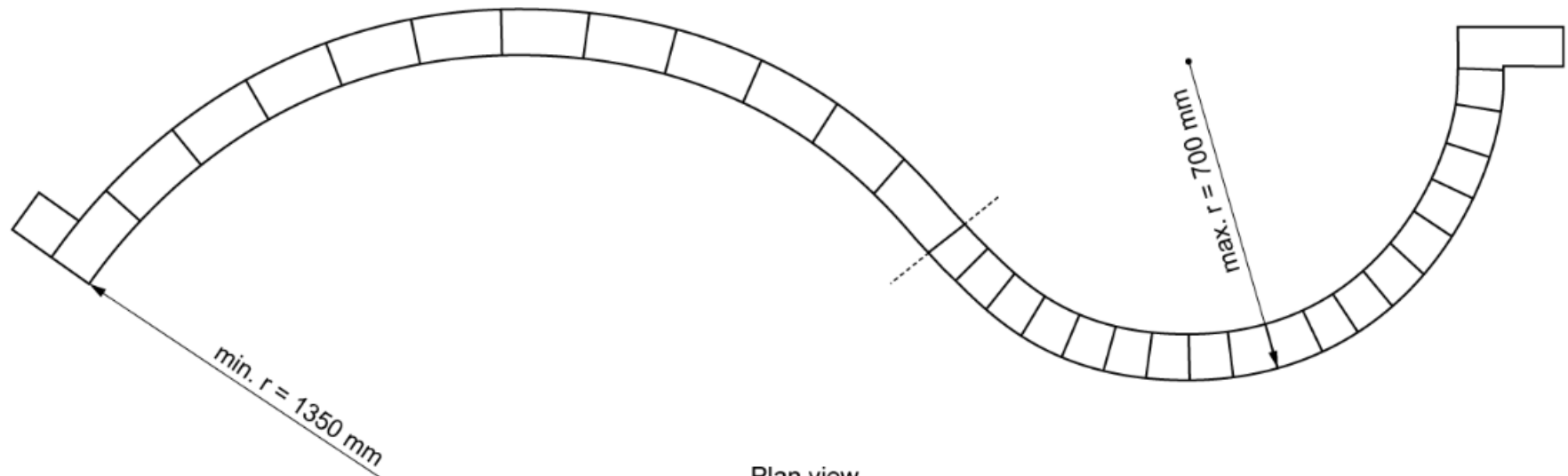

Plan view

Specification
Joint finish:
• Half round - face
• Flush - rear

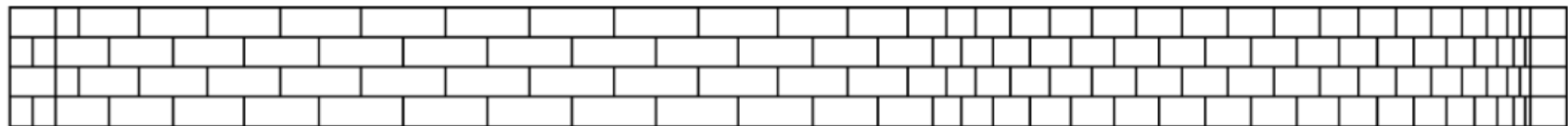

Front elevation

## Drawings and diagrams

### Unit 304 Carrying out decorative and reinforced brickwork

#### Task 1 Build decorative reinforced brickwork

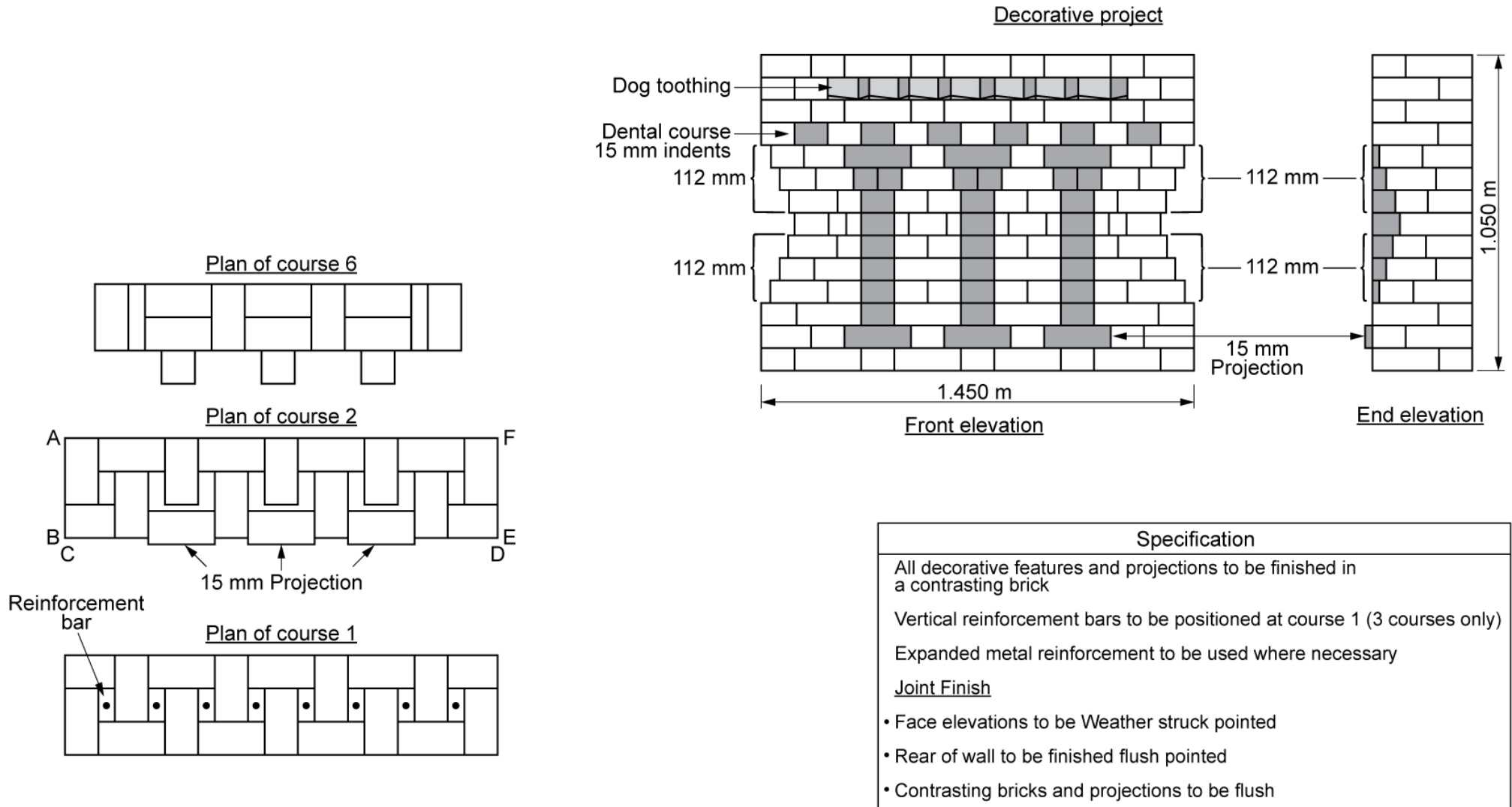

## Drawings and diagrams

### Unit 304 Carrying out decorative and reinforced brickwork

#### Task 2 Build an obtuse quoin

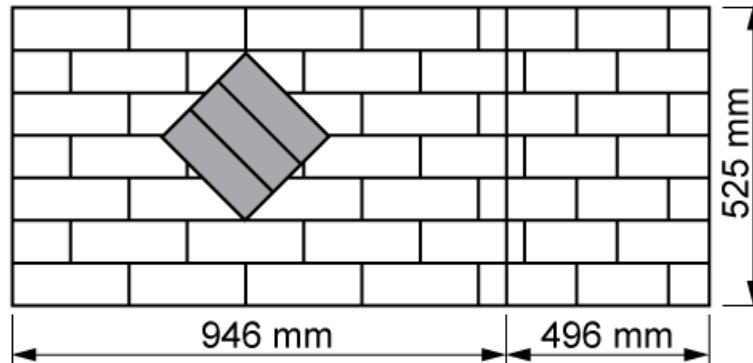

Front elevation

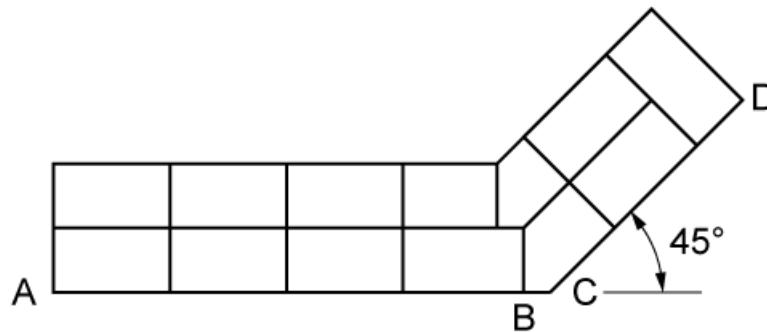

Plan of course 1

#### Specification

Joint finish:

- Face of wall half joint
- Rear of wall to be flushed from trowel

Brick panel to use a contrasting brick

## Drawings and diagrams

### Unit 305 Constructing fireplaces and chimneys

#### Task 1 Build a block wall with flue liners

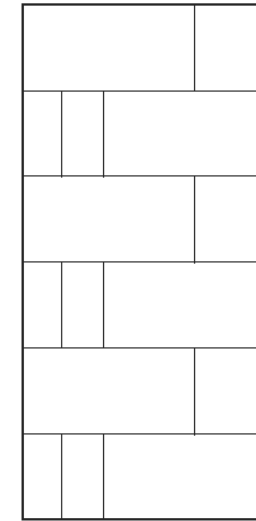
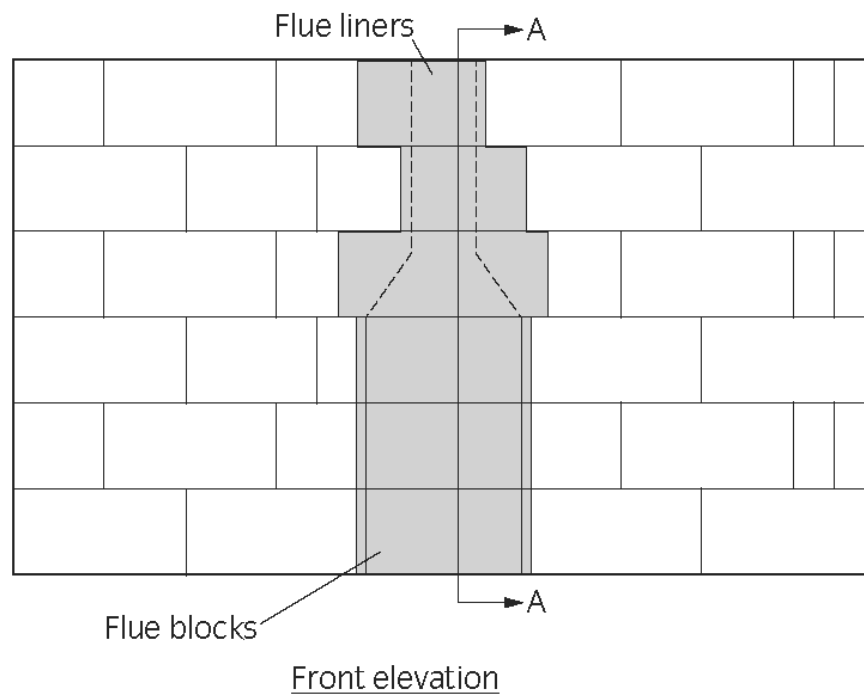

Section A-A

End elevation

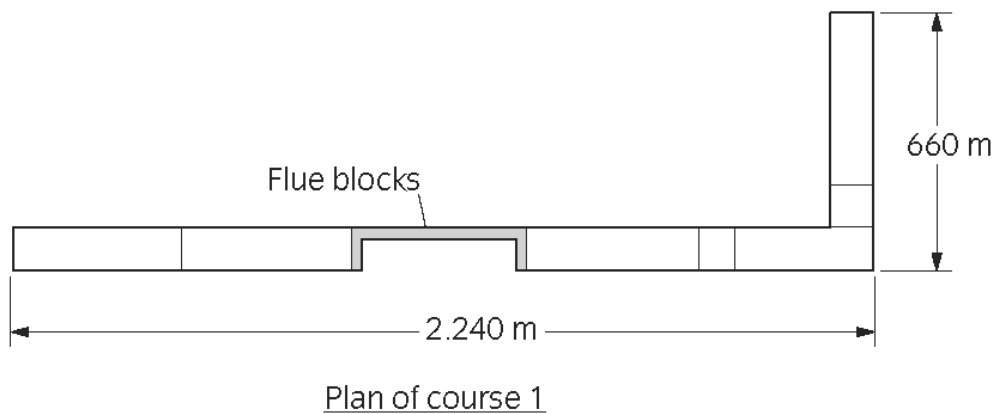

#### Specifications

Reinforcement to be used as per manufacturer's instructions.

Joint finish: flush joint finish to all elevations.

# Drawings and diagrams

## Unit 305 Constructing fireplaces and chimneys

### Task 2 Build a chimney stack

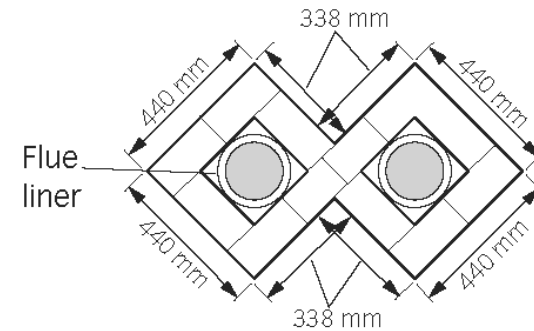
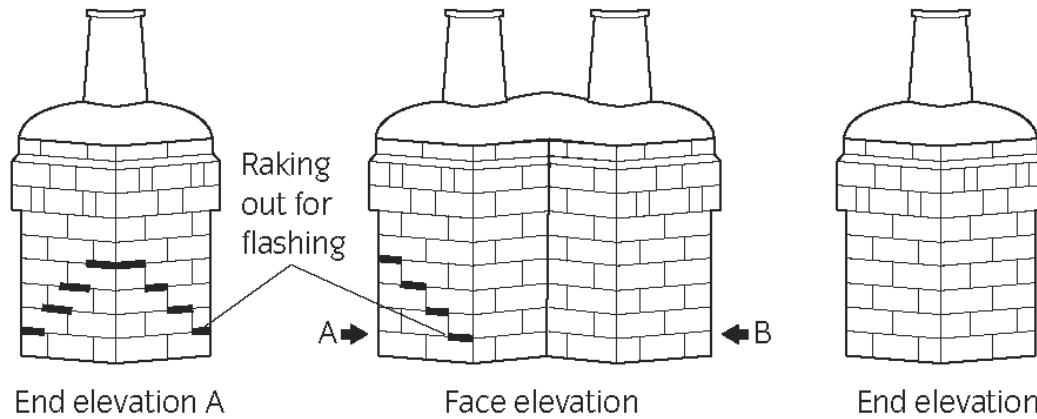

Plan of course 2

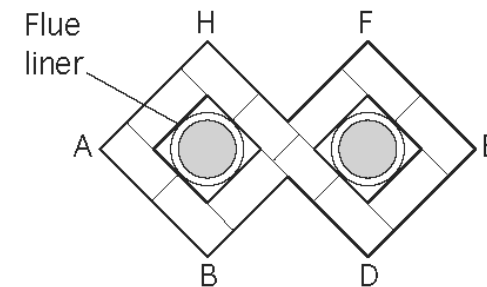

Plan of course 1

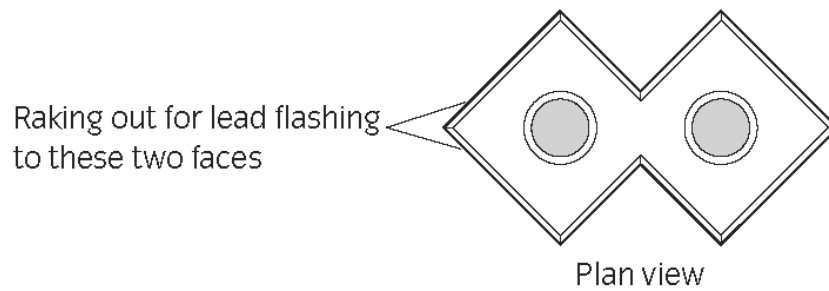

#### Specification

Weather struck joint finish.  
Flaunching and fillet to be correctly formed.















---

**Published by City & Guilds**  
**1 Giltspur Street**  
**London**  
**EC1A 9DD**  
**T +44 (0)844 543 0000**  
**F +44 (0)20 7294 2413**  
**www.cityandguilds.com**

**City & Guilds is a registered charity  
established to promote education  
and training**

#### **About City & Guilds**

As the UK's leading vocational education organisation, City & Guilds is leading the talent revolution by inspiring people to unlock their potential and develop their skills. We offer over 500 qualifications across 28 industries through 8500 centres worldwide and award around two million certificates every year. City & Guilds is recognised and respected by employers across the world as a sign of quality and exceptional training.

#### **City & Guilds Group**

The City & Guilds Group operates from three major hubs: London (servicing Europe, the Caribbean and Americas), Johannesburg (servicing Africa), and Singapore (servicing Asia, Australia and New Zealand). The Group also includes the Institute of Leadership & Management (management and leadership qualifications), City & Guilds Land Based Services (land-based qualifications), the Centre for Skills Development (CSD works to improve the policy and practice of vocational education and training worldwide) and Learning Assistant (an online e-portfolio).

#### **Copyright**

The content of this document is, unless otherwise indicated, © The City and Guilds of London Institute and may not be copied, reproduced or distributed without prior written consent. However, approved City & Guilds centres and candidates studying for City & Guilds qualifications may photocopy this document free of charge and/or include a PDF version of it on centre intranets on the following conditions:

- centre staff may copy the material only for the purpose of teaching candidates working towards a City & Guilds qualification, or for internal administration purposes
- candidates may copy the material only for their own use when working towards a City & Guilds qualification

The *Standard Copying Conditions* (see the City & Guilds website) also apply.

Published by City & Guilds, a registered charity established to promote education and training

Every effort has been made to ensure that the information contained in this publication is true and correct at the time of going to press. However, City & Guilds' products and services are subject to continuous development and improvement and the right is reserved to change products and services from time to time. City & Guilds cannot accept liability for loss or damage arising from the use of information in this publication.