

# **6806-13 Diploma in Carpentry and Joinery at SCQF Level 4**

September 2014 Version 1.1

# Contents

<b>Task manual amendments</b>	<b>1</b>
<b>Candidate details</b>	<b>2</b>
<b>Unit assessment overview</b>	<b>3</b>
Practical task completion record	3
<b>Instructions to candidates</b>	<b>5</b>
<b>Unit 113 Maintain and use carpentry and joinery hand tools</b>	<b>6</b>
Task 1 Maintain and store carpentry and joinery hand tools	6
Task 2 Use carpentry and joinery handsaws	7
Task 3 Use carpentry and joinery hand-held planes	8
Task 4 Use carpentry and joinery chisels	9
<b>Unit 114 Prepare and use carpentry and joinery portable power tools</b>	<b>11</b>
Task 1 Use carpentry and joinery portable power drills and planers	11
Task 2 Use carpentry and joinery portable power saws	13
Task 3 Use carpentry and joinery portable power routers and sanders	14
<b>Unit 115 Produce woodworking joints</b>	<b>15</b>
Task 1 Mark out woodworking joints	15
Task 2 Produce basic woodworking joints and form a frame	17
<b>Drawings and diagrams</b>	<b>19</b>
Unit 113 Maintain and use carpentry and joinery hand tools	19
Unit 114 Prepare and use carpentry and joinery portable power tools	22
Unit 115 Produce woodworking joints	27

# Task manual amendments

## Amendments since version 1.0

Page 26      Unit 114, Task 3 Figure 1 Timber for router and sander amended.

Page 27      Unit 115, Task 1 and 2 Figure 1 Frame amended.

## Candidate details



This *Practical task manual* is a record of your achievement in practical assessments. You must keep it in good condition and it must be stored in a safe place by your Assessor.

Please fill in all of your details before you carry out any assessments.

### Candidate Details

Surname		Forename(s)	
---------	--	-------------	--

City & Guilds enrolment number	
--------------------------------	--

### Centre Details

Name		Centre No	
------	--	-----------	--

I understand the requirements of the qualification and that all the work towards the assessments must be my own.

<b>Candidate signature</b> (please print)	
--	--

<b>Assessor name</b> (please print)		Signed	
--	--	--------	--

Date	
------	--

# Unit assessment overview

## Practical task completion record

### To be completed by Assessor:

For each task, the points for each grade are  
 Pass = 1, Merit = 2, and Distinction = 3 points.

Where there is a weighting given, (see *Assessor guide*: unit assessment overview) multiply the points by the weighting to be applied (eg to apply a weighting of 2, a distinction is:  $3 \times 2 = 6$  points). Do not include pass/fail only tasks in the calculation, only graded.

Conversion chart	
Average	Overall Grade
1 – 1.5	Pass
1.6 – 2.5	Merit
2.6 – 3	Distinction

†All tasks must be passed for the unit to be achieved.

### Unit 113 Maintain and use carpentry and joinery hand tools

Task	Grade for task†	Points (graded tasks)
1 Maintain and store carpentry and joinery hand tools	P / X	
2 Use carpentry and joinery handsaws	P / M / D / X	
3 Use carpentry and joinery hand-held planes	P / M / D / X	
4 Use carpentry and joinery chisels	P / X	
End of unit knowledge test	P / X	
<b>Total</b>		
For graded tasks, divide total points by total number of graded tasks		÷ 2
Average =		
<b>Overall grade</b> (see conversion chart)		

Assessor signature and date:

## Unit 114 Prepare and use carpentry and joinery portable power tools

Task	Grade for task
1 Use carpentry and joinery portable power drills and planers	P / X
2 Use carpentry and joinery portable power saws	P / X
3 Use carpentry and joinery portable power routers and sanders	P / X
End of unit knowledge test	P / X

Assessor signature and date:

Candidates must pass all tasks, and the end of unit knowledge test, for this unit to achieve a pass grade overall.

**Overall grade**

## Unit 115 Produce woodworking joints

Task	Grade for task <sup>†</sup>	Weighting for task	Weighted Points
1 Mark out woodworking joints	P / M / D / X	1	
2 Produce basic woodworking joints and form a frame	P / M / D / X	2	
End of unit knowledge test	P / X		
<b>Total</b>			
For graded tasks, divide total points by total of weightings			÷ 3
Average =			
<b>Overall grade</b> (see conversion chart)			

Assessor signature and date:

For graded tasks, divide total points by total of weightings

Average =

**Overall grade**  
(see conversion chart)

## Authenticity and IQA/QC sampling

The assessor's signature on individual tasks will be taken as assurance that the judgements recorded are made on authentic candidate work produced under appropriate conditions. Please complete the declaration below to confirm this is the case.

I confirm that all tasks were conducted under conditions designed to assure the authenticity of the candidate's work, and am satisfied that, to the best of my knowledge, the work assessed was solely that of the candidate.

I have judged all assessments against the relevant assessment and grading criteria and award the candidate the unit grades as calculated above.

Assessor signature

Date

\*IQA signature and date

\*QC signature and date

\*IQA and QC signatures attest to the evidence available on the recorded date(s).

# Instructions to candidates

## About this document

This *Practical task manual* contains all of the practical assessment for the 6806-13 Diploma in Carpentry and Joinery at SCQF Level 4.

## Practical tasks

These tasks let you show your practical skills and are usually graded pass, merit or distinction – a few are pass only. These tasks will be assessed by your assessor watching how you carry out the tasks and checking your final pieces of work.

Before you carry out the task you will be told how it will be assessed and you should read the observation checklist at the end of each task so you know what you need to do to get each grade.

You can ask your assessor for help in understanding the task instructions, but all of the work must be your own.

## Health and safety

You must use safe working practices at all times.

You are responsible for your own safety and the safety of others. If you behave in an unsafe way, you will be stopped and given a warning. If you do not meet all of the Health and Safety requirements, the assessment will be stopped. Your assessor will not be able to let you try the task again until they are sure you can work safely.

## Time considerations

Each task shows how long it is likely to take. This is for guidance and so you can plan your work. If you have a good reason for needing more time you must explain this to your assessor as soon as possible so they can decide whether you can have more time.

## Security

Where an assignment is taken over more than one session, all documentation, paperwork and work products must be labelled carefully with your name and kept securely at the centre. Your assessor will give you directions about how to leave your work.

## Opportunities to repeat tasks

The tasks are 'end tests' so you will only be asked to take the assessment when you have had the chance to do all of the learning and practice you need. You will be able to try the whole task again if you do not pass, but you will not be able to take the assessment again just to try to get a better grade.

## Feedback

As well as telling you the result for the task your assessor will give you feedback. They will give you a feedback sheet with details of what you could do to improve, and also what you did well in. This will help you to prepare for other assessments or to retake the assessment if you need to.

## Unit 113 Maintain and use carpentry and joinery hand tools

### Task 1 Maintain and store carpentry and joinery hand tools

<b>Expected time</b>	45 minutes
<b>Task instructions</b>	<ul style="list-style-type: none"> <li>Sharpen a chisel.</li> <li>Sharpen a plane.</li> <li>Store the tools.</li> <li>Work according to the risk assessment and environmental and health and safety regulations.</li> </ul>

#### Observation checklist

AC	The candidate has	Pass	Merit	Distinction
2.1	worked to a given risk assessment for using hand tools	<input type="checkbox"/>		
2.2	honed and prepared hand tools ready for use <ul style="list-style-type: none"> <li>safely removed blade from plane using correct tools</li> </ul>	<input type="checkbox"/>		
	<ul style="list-style-type: none"> <li>honed plane blade on diamond or oilstone to correct angle and square, with burr removed</li> </ul>	<input type="checkbox"/>		
	<ul style="list-style-type: none"> <li>honed chisel on diamond or oilstone to correct angle and square, with burr removed</li> </ul>	<input type="checkbox"/>		
	<ul style="list-style-type: none"> <li>correctly re-assembled plane and set up for use</li> </ul>	<input type="checkbox"/>		
2.3	stored hand tools and materials in a secure and safe manner, in line with centre procedures	<input type="checkbox"/>		
	retracted blade on plane	<input type="checkbox"/>		
2.4	followed current environmental and relevant health and safety regulations relating to working with carpentry and joinery hand tools, including <ul style="list-style-type: none"> <li>keeping a clean and tidy work area</li> </ul>	<input type="checkbox"/>		

Task grading rules		Task grade:
To award a <b>pass</b> : every activity in the checklist must be successfully achieved.		
Assessor	Signature & Date	



# Unit 113 Maintain and use carpentry and joinery hand tools

## Task 2 Use carpentry and joinery handsaws

<b>Expected time</b>	1 hour
<b>Task instructions</b>	<ul style="list-style-type: none"> <li>• Rip timber to 70 mm wide, as shown in Cut A.</li> <li>• Crosscut timber to 400 mm long as shown in Cut B.</li> <li>• Cut 50 mm radius corner as shown in Cut C.</li> <li>• Work according to environmental and health and safety regulations.</li> </ul>
<b>Diagrams</b>	Figure 1 Handsaw cuts page 19

### Observation checklist

AC	The candidate has	Pass	Merit	Distinction
4.1	used carpentry and joinery handsaws to perform tasks in accordance with Figure 1 <ul style="list-style-type: none"> <li>• Cut A – ripped timber to width (not under size)</li> </ul>	<input type="checkbox"/> within 3 mm	<input type="checkbox"/> within 2 mm	<input type="checkbox"/> within 1 mm
	<ul style="list-style-type: none"> <li>• Cut A – ripped timber square within 1 mm over 15 mm thickness</li> </ul>	<input type="checkbox"/>		
	<ul style="list-style-type: none"> <li>• Cut B – crosscut timber to length and square across the face (not undersize)</li> </ul>	<input type="checkbox"/> within 3 mm	<input type="checkbox"/> within 2 mm	<input type="checkbox"/> within 1 mm
	<ul style="list-style-type: none"> <li>• Cut B – crosscut timber square, within 1 mm, over 15 mm thickness</li> </ul>	<input type="checkbox"/>		
	<ul style="list-style-type: none"> <li>• Cut C – cut curve in timber accurately</li> </ul>	<input type="checkbox"/> within 3 mm	<input type="checkbox"/> within 2 mm	<input type="checkbox"/> within 1 mm
4.2	followed current environmental and relevant health and safety regulations relating to working with carpentry and joinery handsaws, including <ul style="list-style-type: none"> <li>• keeping a clean and tidy work area</li> </ul>	<input type="checkbox"/>		

Task grading rules		Task grade:
To award a <b>pass</b> : every activity in the checklist must be successfully achieved.		
To award a <b>merit</b> : in addition to the above, all <b>3</b> graded activities in the checklist must be achieved to <b>at least</b> a merit standard.		
To award a <b>distinction</b> : in addition to both of the above, all <b>3</b> graded activities in the checklist must be achieved to a distinction standard.		
Assessor	Signature & Date	

# Unit 113 Maintain and use carpentry and joinery hand tools

## Task 3 Use carpentry and joinery hand-held planes

<b>Expected time</b>	2 hours
<b>Task instructions</b>	<ul style="list-style-type: none"> <li>Plane a piece of timber flat, straight, square and parallel to a finished size of 68 mm x 43 mm.</li> <li>Rebate the timber as per Figure 1.</li> <li>Chamfer the end grain.</li> <li>Work according to environmental and health and safety regulations.</li> </ul>
<b>Diagrams</b>	Figure 1 Block to plane and rebate page 20

### Observation checklist

AC	The candidate has	Pass	Merit	Distinction
6.1	used carpentry and joinery hand-held planes to perform tasks in accordance with Figure 1 <ul style="list-style-type: none"> <li>timber planed straight within 0.5 mm across four faces</li> </ul>	<input type="checkbox"/>		
	<ul style="list-style-type: none"> <li>timber planed flat, square and parallel to finished size of 68 mm x 43 mm (not undersize)</li> </ul>	<input type="checkbox"/> within 3 mm	<input type="checkbox"/> within 2 mm	<input type="checkbox"/> within 1 mm
	<ul style="list-style-type: none"> <li>rebated as per Figure 1 with dimensions (not over sized)</li> </ul>	<input type="checkbox"/> within 2 mm	<input type="checkbox"/> within 1 mm	<input type="checkbox"/> within 0.5 mm
	<ul style="list-style-type: none"> <li>end grain chamfered within 1 mm of Figure 1 dimensions</li> </ul>	<input type="checkbox"/>		
	<ul style="list-style-type: none"> <li>end grain chamfered flat and without breakout</li> </ul>	<input type="checkbox"/>		
6.2	followed current environmental and relevant health and safety regulations relating to working with hand-held planes, including <ul style="list-style-type: none"> <li>keeping a clean and tidy work area</li> </ul>	<input type="checkbox"/>		

Task grading rules	Task grade:
To award a <b>pass</b> : every activity in the checklist must be successfully achieved.	
To award a <b>merit</b> : in addition to the above, both (2) graded activities in the checklist must be achieved to <b>at least</b> a merit standard.	
To award a <b>distinction</b> : in addition to both of the above, both (2) graded activities in the checklist must be achieved to a distinction standard.	
Assessor	Signature & Date

# Unit 113 Maintain and use carpentry and joinery hand tools

## Task 4 Use carpentry and joinery chisels

<b>Expected time</b>	2 hours 30 minutes
<b>Task instructions</b>	<ul style="list-style-type: none"> <li>• Cut a through housing.</li> <li>• Chop a through mortice.</li> <li>• Chop a recess.</li> <li>• Produce a stopped chamfer.</li> <li>• Work according to environmental and health and safety regulations.</li> </ul>
<b>Diagrams</b>	Figure 1 Timber block for chisel task page 21

### Observation checklist

AC	The candidate has	Pass	Merit	Distinction
8.1	use carpentry and joinery chisels and mallet to perform tasks in accordance with Figure 1 <ul style="list-style-type: none"> <li>• cut the through housing width to the dimensions on Figure 1 to within 1 mm (not over sized).</li> </ul>	<input type="checkbox"/>		
	<ul style="list-style-type: none"> <li>• cut the through housing depth to the dimensions on Figure 1 (<math>\pm 1</math> mm)</li> </ul>	<input type="checkbox"/>		
	<ul style="list-style-type: none"> <li>• chopped the through mortice to the dimensions on Figure 1 within 1 mm (not over sized)</li> </ul>	<input type="checkbox"/>		
	<ul style="list-style-type: none"> <li>• mortice width and length consistent to accept a dummy tenon</li> </ul>	<input type="checkbox"/>		
	<ul style="list-style-type: none"> <li>• mortice chopped without bruising</li> </ul>	<input type="checkbox"/>		
	<ul style="list-style-type: none"> <li>• mortice chopped with no breakout</li> </ul>	<input type="checkbox"/>		
	<ul style="list-style-type: none"> <li>• chopped a recess to the dimensions on Figure 1 to within 1 mm (not over sized)</li> </ul>	<input type="checkbox"/>		
	<ul style="list-style-type: none"> <li>• chopped recess to the depth shown on Figure 1 (<math>\pm 1</math> mm)</li> </ul>	<input type="checkbox"/>		
	<ul style="list-style-type: none"> <li>• produced a stopped chamfer to length (<math>\pm 2</math> mm)</li> </ul>	<input type="checkbox"/>		
	<ul style="list-style-type: none"> <li>• produced a stopped chamfer parallel (<math>\pm 1</math> mm)</li> </ul>	<input type="checkbox"/>		
	<ul style="list-style-type: none"> <li>• produced a stopped chamfer to depth (<math>\pm 1</math> mm)</li> </ul>	<input type="checkbox"/>		
8.2	followed current environmental and relevant health and safety regulations related to working with carpentry and joinery chisels, including <ul style="list-style-type: none"> <li>• keeping a clean and tidy work area</li> </ul>	<input type="checkbox"/>		

Task grading rules		Task grade:
To award a <b>pass</b> : every activity in the checklist must be successfully achieved.		
Assessor	Signature & Date	

## Unit 114 Prepare and use carpentry and joinery portable power tools

### Task 1 Use carpentry and joinery portable power drills and planers

<b>Expected time</b>	4 hours
<b>Task instructions</b>	<ul style="list-style-type: none"> <li>• Plane timber to a width of 68 mm.</li> <li>• Drill, countersink and fix batten.</li> <li>• Rebate.</li> <li>• Chamfer.</li> <li>• Drill holes.</li> <li>• Work according to environmental and health and safety regulations (including PUWER).</li> </ul>
<b>Diagrams</b>	Figure 1 Batten page 22 Figure 2 Timber block with batten page 23

#### Observation checklist

AC	The candidate has	Pass	Merit	Distinction
2.1 2.2 2.5	checked cables, power tools and guards, including checking for a valid test certificate	<input type="checkbox"/>		
2.4	changed planer blades correctly	<input type="checkbox"/>		
8.1	adjusted and used portable power planer to work timber in accordance with Figure 2 <ul style="list-style-type: none"> <li>• planed to width within 1 mm</li> </ul>	<input type="checkbox"/>		
2.3 4.1	used portable power drills to perform tasks in accordance with Figures 1 and 2 <ul style="list-style-type: none"> <li>• drilled, countersunk and fixed batten flush within 1 mm, as per Figures 1 and 2</li> </ul>	<input type="checkbox"/>		
8.1	<ul style="list-style-type: none"> <li>• planed rebate width within 1 mm, as per Figure 2</li> </ul>	<input type="checkbox"/>		
	<ul style="list-style-type: none"> <li>• planed rebate depth within 1 mm, as per Figure 2</li> </ul>	<input type="checkbox"/>		
	<ul style="list-style-type: none"> <li>• produced a chamfer parallel (<math>\pm 1</math> mm)</li> </ul>	<input type="checkbox"/>		
	<ul style="list-style-type: none"> <li>• produced a chamfer to depth (<math>\pm 1</math> mm)</li> </ul>	<input type="checkbox"/>		
4.1	<ul style="list-style-type: none"> <li>• drilled two holes through with a flat bit (10-12 mm) with no break out</li> </ul>	<input type="checkbox"/>		
	<ul style="list-style-type: none"> <li>• drilled flat bit holes through square in both directions (<math>\pm 1</math> mm)</li> </ul>	<input type="checkbox"/>		
2.4	<ul style="list-style-type: none"> <li>• changed tooling correctly</li> </ul>	<input type="checkbox"/>		
	<ul style="list-style-type: none"> <li>• drilled two blind holes to depth with an auger bit (15-18 mm) (<math>\pm 1</math> mm)</li> </ul>	<input type="checkbox"/>		

AC	The candidate has	Pass	Merit	Distinction
	<ul style="list-style-type: none"> <li>all four holes centred in correct positions within 2 mm, as per Figure 2</li> </ul>	<input type="checkbox"/>		
2.6	<ul style="list-style-type: none"> <li>cleaned and stored power tools safely and securely on completion</li> </ul>	<input type="checkbox"/>		
2.7 4.2 8.3	followed current environmental and relevant health and safety regulations relating to working with portable power drills and a power planer	<input type="checkbox"/>		

Task grading rules		Task grade:
To award a <b>pass</b> : every activity in the checklist must be successfully achieved.		
Assessor	Signature & Date	

## Unit 114 Prepare and use carpentry and joinery portable power tools

### Task 2 Use carpentry and joinery portable power saws

<b>Expected time</b>	1 hour
<b>Task instructions</b>	<ul style="list-style-type: none"> <li>• Use a chopsaw to cut angles across the face and down the edge of the timber.</li> <li>• Use a jigsaw to cut curves and shapes in manufactured board material.</li> <li>• Work according to environmental and health and safety regulations (including PUWER).</li> </ul>
<b>Diagrams</b>	Figure 1 Timber block for chopsaw page 24 Figure 2 Manufactured board for jigsaw page 25

#### Observation checklist

AC	The candidate has	Pass	Merit	Distinction
2.1 2.2 2.5	checked cables, power tools and guards, including checking for a valid test certificate	<input type="checkbox"/>		
6.1	used portable power chop saw to cut timber in accordance with Figure 1	<input type="checkbox"/>		
	<ul style="list-style-type: none"> <li>• cut a 63° angle across the face of the timber as per Figure 1</li> </ul>	<input type="checkbox"/>		
	<ul style="list-style-type: none"> <li>• cut a 75° angle through the thickness of the timber as per Figure 1</li> </ul>	<input type="checkbox"/>		
	<ul style="list-style-type: none"> <li>• timber cut to length (<math>\pm 1</math> mm)</li> </ul>	<input type="checkbox"/>		
2.4	changed jigsaw blade correctly	<input type="checkbox"/>		
6.2	used portable power jigsaw to cut board materials in accordance with Figure 2	<input type="checkbox"/>		
	<ul style="list-style-type: none"> <li>• cut an external curve with a radius of 150 mm as per Figure 2 (+ 2 mm, not under sized)</li> </ul>	<input type="checkbox"/>		
	<ul style="list-style-type: none"> <li>• cut internal aperture as per Figure 2</li> </ul>	<input type="checkbox"/>		
2.6	cleaned and stored power tools safely and securely on completion	<input type="checkbox"/>		
6.3	followed current environmental and relevant health and safety regulations relating to working with portable power saws	<input type="checkbox"/>		

<b>Task grading rules</b>		<b>Task grade:</b>
To award a <b>pass</b> : every activity in the checklist must be successfully achieved.		
Assessor	Signature & Date	

## Unit 114 Prepare and use carpentry and joinery portable power tools

### Task 3 Use carpentry and joinery portable power routers and sanders

<b>Expected time</b>	2 hours
<b>Task instructions</b>	<ul style="list-style-type: none"> <li>Router a piece of timber to form             <ul style="list-style-type: none"> <li>a housing</li> <li>a rebate</li> <li>an ovolo mould.</li> </ul> </li> <li>Sand the face side.</li> <li>Work according to environmental and health and safety regulations (including PUWER).</li> </ul>
<b>Diagrams</b>	Figure 1 Timber for router and sander page 26

#### Observation checklist

AC	The candidate has	Pass	Merit	Distinction
8.2	adjusted and used portable power router to work timber in accordance with Figure 1 <ul style="list-style-type: none"> <li>housing routered to position within 1 mm</li> </ul>	<input type="checkbox"/>		
	<ul style="list-style-type: none"> <li>housing to depth (<math>\pm 1</math> mm)</li> </ul>	<input type="checkbox"/>		
	<ul style="list-style-type: none"> <li>rebate to width (<math>\pm 1</math> mm)</li> </ul>	<input type="checkbox"/>		
	<ul style="list-style-type: none"> <li>rebate to depth (<math>\pm 1</math> mm)</li> </ul>	<input type="checkbox"/>		
	<ul style="list-style-type: none"> <li>ovolo mould to depth (<math>\pm 1</math> mm)</li> </ul>	<input type="checkbox"/>		
	<ul style="list-style-type: none"> <li>ovolo corner square without rounding</li> </ul>	<input type="checkbox"/>		
2.4	<ul style="list-style-type: none"> <li>router cutters changed correctly according to manufacturer's instructions</li> </ul>	<input type="checkbox"/>		
10.1	used portable power orbital sander to finish work in accordance with Figure 1 <ul style="list-style-type: none"> <li>sanded off marking out lines from face side, without rounding the edges</li> </ul>	<input type="checkbox"/>		
8.3 10.2	followed current environmental and relevant health and safety regulations relating to working with portable power routers and sanders	<input type="checkbox"/>		

Task grading rules		Task grade:
To award a <b>pass</b> : every activity in the checklist must be successfully achieved.		
Assessor	Signature & Date	



# Unit 115 Produce woodworking joints

## Task 1 Mark out woodworking joints

<b>Expected time</b>	2 hours
<b>Task instructions</b>	<ul style="list-style-type: none"> <li>• Produce a setting out rod showing all joint details in Figures 1-7.</li> <li>• Use to mark out the timber.</li> <li>• Work according to environmental and health and safety regulations.</li> </ul>
<b>Diagrams</b>	<p>Figure 1 Frame page 27            Figure 2 Tee bridle joint A page 28            Figure 3 Tee halving joint B page 29            Figure 4 Mortice and tenon joint C page 30            Figure 5 Dovetail halving joint D page 31            Figure 6 Stub mortice and tenon joint E page 32            Figure 7 Cross halving joint F page 33</p>

### Observation checklist

AC	The candidate has	Pass	Merit	Distinction
4.1	produced a setting out rod	<input type="checkbox"/>		
	<ul style="list-style-type: none"> <li>• overall height within 1 mm</li> </ul>	<input type="checkbox"/>		
	<ul style="list-style-type: none"> <li>• overall width within 1 mm</li> </ul>	<input type="checkbox"/>		
	<ul style="list-style-type: none"> <li>• joint positions within 1 mm</li> </ul>	<input type="checkbox"/>		
4.2	used a setting out rod when marking out	<input type="checkbox"/>		
4.3	used appropriate marking out tools to mark out	<input type="checkbox"/>		
5.1	<ul style="list-style-type: none"> <li>• face and edge correctly selected and marked</li> </ul>	<input type="checkbox"/>		
	<ul style="list-style-type: none"> <li>• joint positions as per rod</li> </ul>	<input type="checkbox"/>		
	<ul style="list-style-type: none"> <li>• shoulder lines square</li> </ul>	<input type="checkbox"/>		
	<ul style="list-style-type: none"> <li>• gauging central</li> </ul>	<input type="checkbox"/> ± 2 mm	<input type="checkbox"/> ± 1 mm	<input type="checkbox"/> 0 mm
	<ul style="list-style-type: none"> <li>• gauging for tenon set to mortice chisel</li> </ul>	<input type="checkbox"/>		
	<ul style="list-style-type: none"> <li>• dovetail pitch correctly set</li> </ul>	<input type="checkbox"/> ± 2 mm	<input type="checkbox"/> ± 1 mm	<input type="checkbox"/> 0 mm
	<ul style="list-style-type: none"> <li>• marked out wedge allowance</li> </ul>	<input type="checkbox"/>		
4.4	followed current environmental and relevant health and safety regulations relating to marking out woodworking joints	<input type="checkbox"/>		

Task grading rules		Task grade:
To award a <b>pass</b> : every activity in the checklist must be successfully achieved.		
To award a <b>merit</b> : in addition to the above, both <b>(2)</b> graded activities in the checklist must be achieved to <b>at least</b> a merit standard.		
To award a <b>distinction</b> : in addition to both of the above, both <b>(2)</b> graded activities in the checklist must be achieved to a distinction standard.		
Assessor	Signature & Date	

# Unit 115 Produce woodworking joints

## Task 2 Produce basic woodworking joints and form a frame

<b>Expected time</b>	8 hours
<b>Task instructions</b>	<ul style="list-style-type: none"> <li>• Work to a risk assessment.</li> <li>• Complete a resource checklist.</li> <li>• Produce the joints marked out in Task 1.</li> <li>• Assemble the frame.</li> <li>• Clean up the frame.</li> <li>• Work according to environmental and health and safety regulations.</li> </ul>
<b>Diagrams</b>	<p>Figure 1 Frame page 27</p> <p>Figure 2 Tee bridle joint A page 28</p> <p>Figure 3 Tee halving joint B page 29</p> <p>Figure 4 Mortice and tenon joint C page 30</p> <p>Figure 5 Dovetail halving joint D page 31</p> <p>Figure 6 Stub mortice and tenon joint E page 32</p> <p>Figure 7 Cross halving joint F page 33</p>

### Observation checklist

AC	The candidate has	Pass	Merit	Distinction
5.2	worked to a given risk assessment for using hand tools	<input type="checkbox"/>		
7.1	<p>produced and assembled woodworking joints (dry fit first) to form the frame as per Figures 1-7</p> <ul style="list-style-type: none"> <li>• joints tight fitting on both faces with no gaps exceeding 1 mm</li> </ul> <p>(no joints to have any more than a 2 mm gap)</p>	<input type="checkbox"/> Four of six joints	<input type="checkbox"/> Five of six joints	<input type="checkbox"/> All six joints
	<ul style="list-style-type: none"> <li>• joints tight fitting on edges with no gaps exceeding 1 mm</li> </ul> <p>(no joints to have any more than a 2 mm gap)</p>	<input type="checkbox"/> Four of six joints	<input type="checkbox"/> Five of six joints	<input type="checkbox"/> All six joints
	<ul style="list-style-type: none"> <li>• joints correctly positioned as per Figure 1</li> </ul>	<input type="checkbox"/> ± 3 mm	<input type="checkbox"/> ± 2 mm	<input type="checkbox"/> ± 1 mm
	<ul style="list-style-type: none"> <li>• overall height and width correct</li> </ul>	<input type="checkbox"/> ± 3 mm	<input type="checkbox"/> ± 2 mm	<input type="checkbox"/> ± 1 mm
	<ul style="list-style-type: none"> <li>• frame square</li> </ul>	<input type="checkbox"/> ± 3 mm	<input type="checkbox"/> ± 2 mm	<input type="checkbox"/> ± 1 mm
	<ul style="list-style-type: none"> <li>• screws countersunk flush with surface</li> </ul>	<input type="checkbox"/>		
	<ul style="list-style-type: none"> <li>• wedges inserted and not split</li> </ul>	<input type="checkbox"/>		

AC	The candidate has	Pass	Merit	Distinction
	<ul style="list-style-type: none"> <li>twist not exceeding 2 mm</li> </ul>	<input type="checkbox"/>		
	<ul style="list-style-type: none"> <li>frame parallel both ways within 2 mm</li> </ul>	<input type="checkbox"/>		
	<ul style="list-style-type: none"> <li>planed up inside edges prior to assembling</li> </ul>	<input type="checkbox"/>		
	<ul style="list-style-type: none"> <li>planed up ready for varnished finish without plane marks</li> </ul>	<input type="checkbox"/>		
	<ul style="list-style-type: none"> <li>timber thickness and width</li> </ul>	<input type="checkbox"/> within 3 mm	<input type="checkbox"/> within 2 mm	<input type="checkbox"/> within 1 mm
5.1 5.3 5.4	selected and used correct tools and equipment (candidates should complete the resource checklist provided)	<input type="checkbox"/>		
5.5	kept tools sharp and defects reported as appropriate	<input type="checkbox"/>		
5.6 7.2	followed current environmental and relevant health and safety regulations relating to using woodworking hand tools and joints, including <ul style="list-style-type: none"> <li>keeping a clean and tidy work area</li> </ul>	<input type="checkbox"/>		

Task grading rules		Task grade:
To award a <b>pass</b> : every activity in the checklist must be successfully achieved.		
To award a <b>merit</b> : in addition to the above, <b>4</b> out of <b>6</b> graded activities in the checklist must be achieved to <b>at least</b> a merit standard.		
To award a <b>distinction</b> : <b>4</b> out of <b>6</b> graded activities in the checklist must be achieved to <b>at least</b> a distinction standard, and <b>2</b> of the remaining graded activities must be achieved to <b>at least</b> a merit standard.		
Assessor	Signature & Date	

## Drawings and diagrams

### Unit 113 Maintain and use carpentry and joinery hand tools

#### Task 2 Use carpentry and joinery handsaws

Figure 1: Handsaw cuts

Diagram not to scale

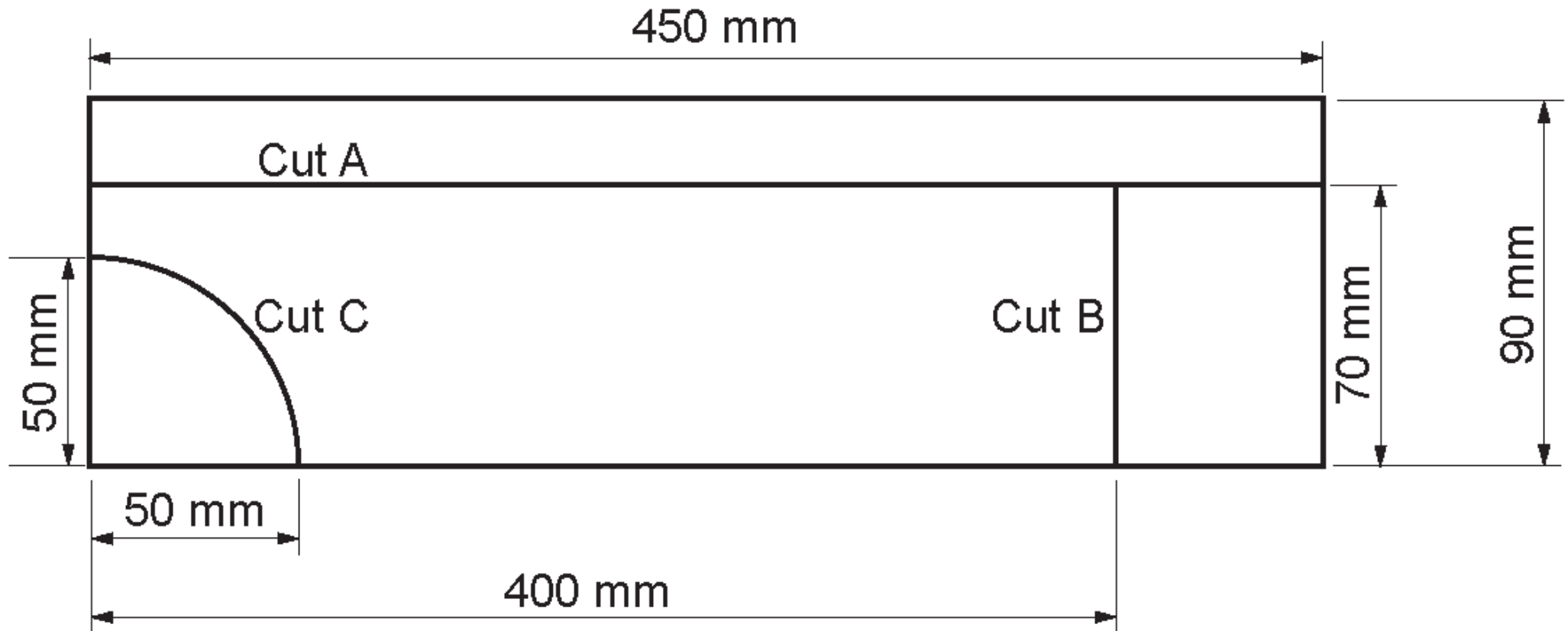

## Drawings and diagrams

### Unit 113 Maintain and use carpentry and joinery hand tools

#### Task 3 Use carpentry and joinery hand-held planes

Figure 1: Block to plane and rebate

Diagram not to scale

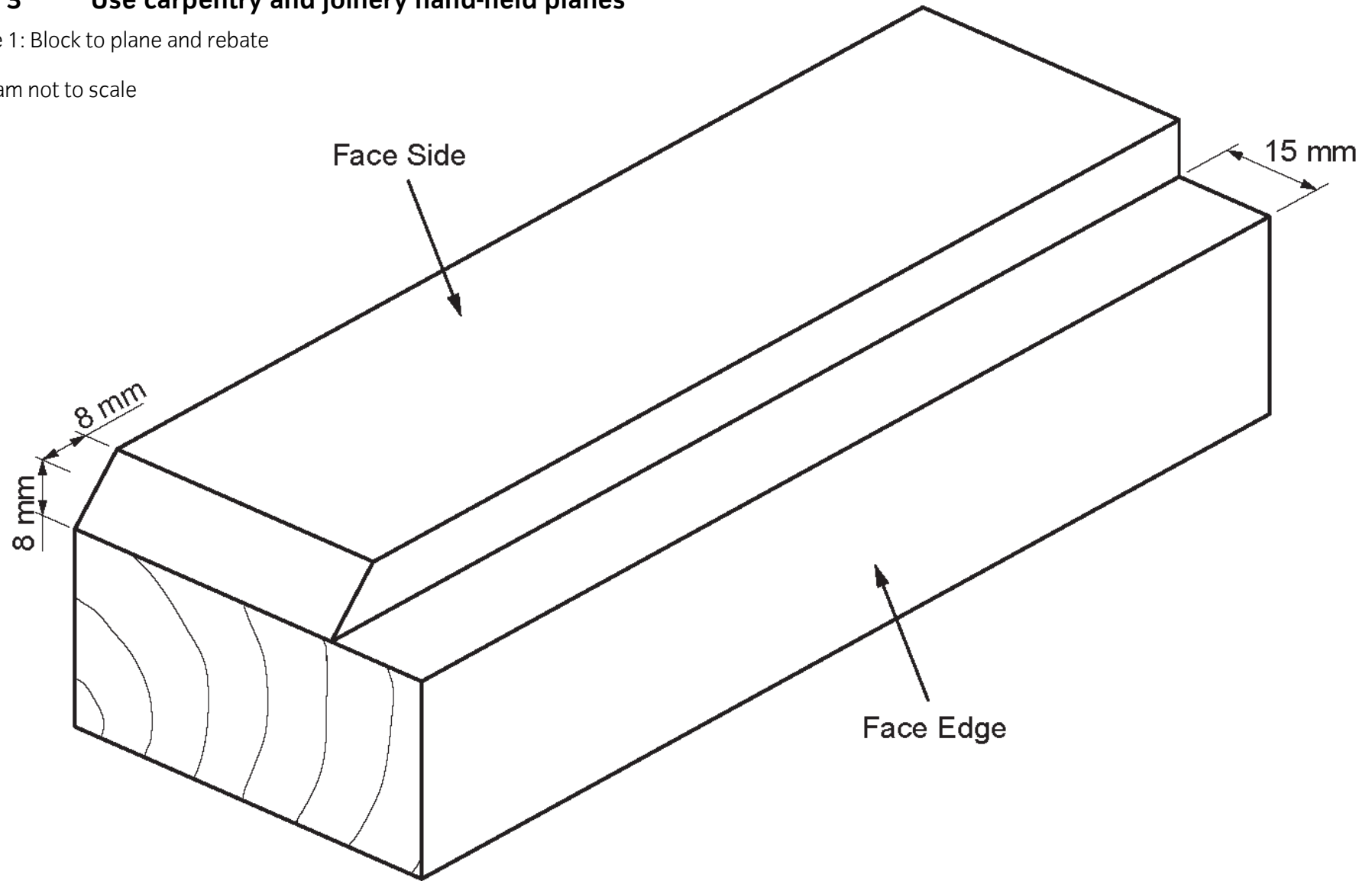

## Drawings and diagrams

### Unit 113 Maintain and use carpentry and joinery hand tools

#### Task 4 Use carpentry and joinery chisels

Figure 1: Timber block for chisel task

Diagram not to scale

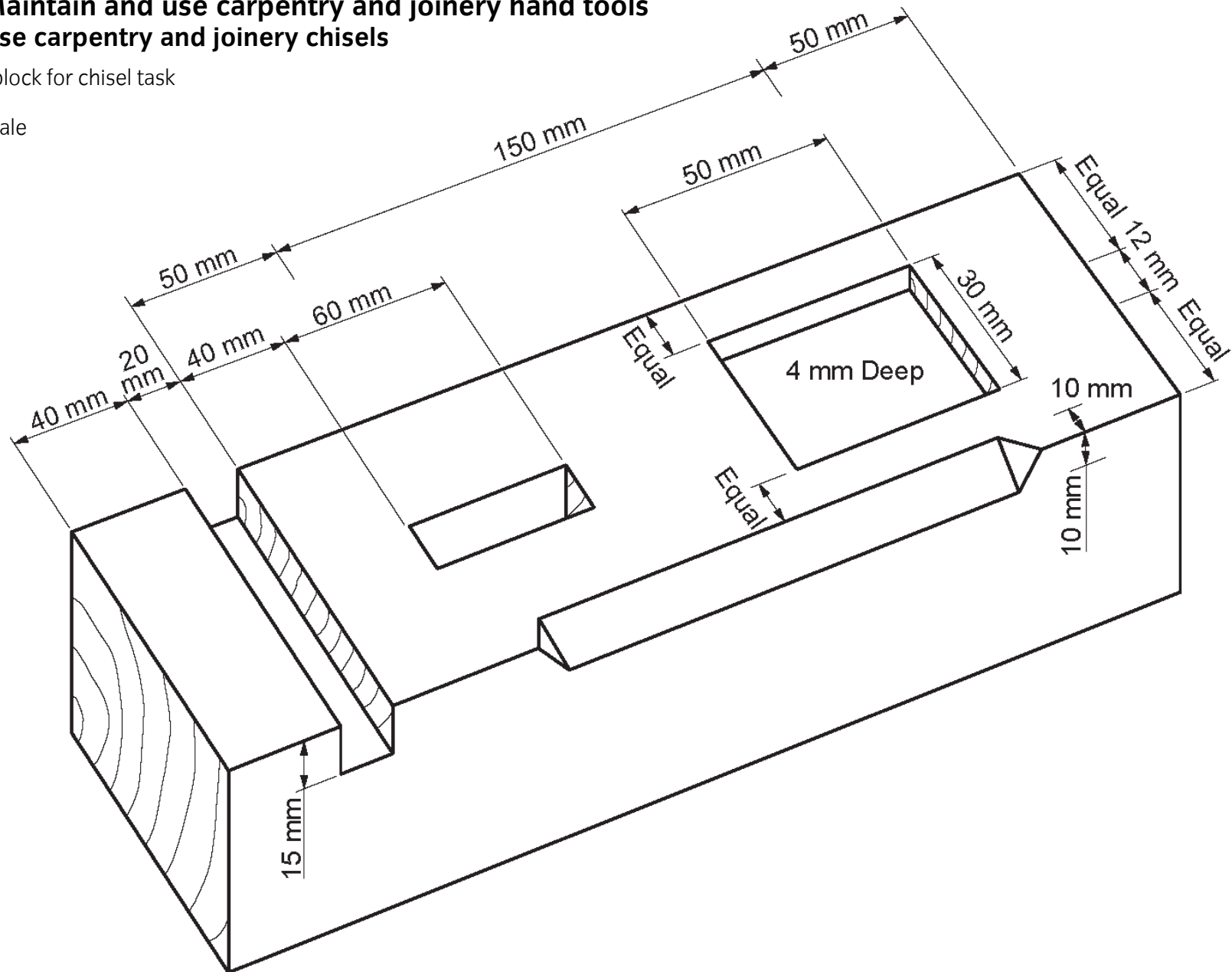

## Drawings and diagrams

### Unit 114 Prepare and use carpentry and joinery portable power tools

#### Task 1 Use carpentry and joinery portable power drills and planers

Figure 1: Batten

Diagram not to scale

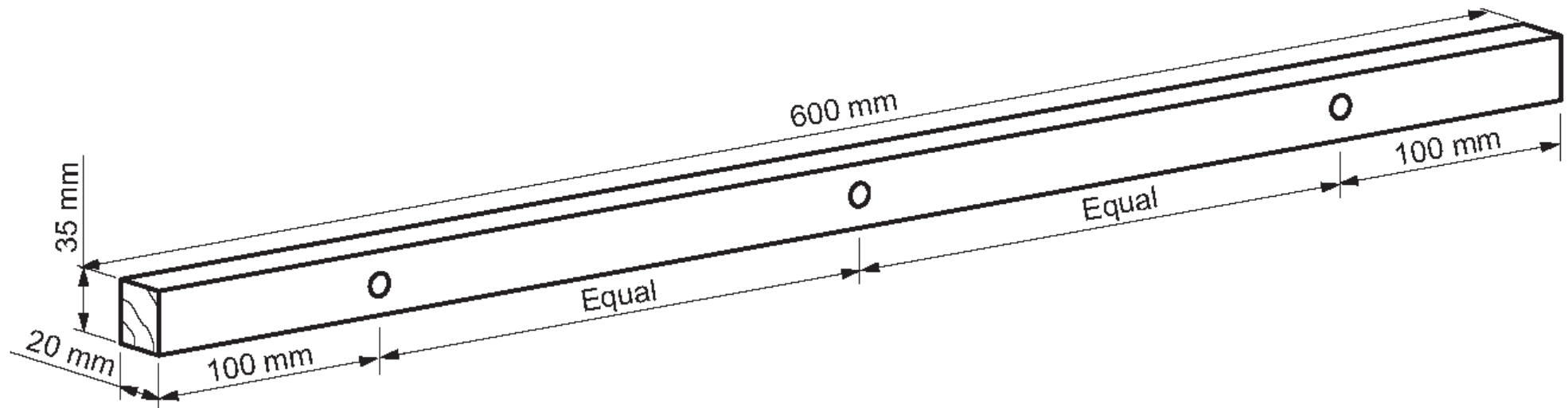



## Drawings and diagrams

### Unit 114 Prepare and use carpentry and joinery portable power tools

#### Task 1 Use carpentry and joinery portable power drills and planers

Figure 2: Timber block with batten

Diagram not to scale

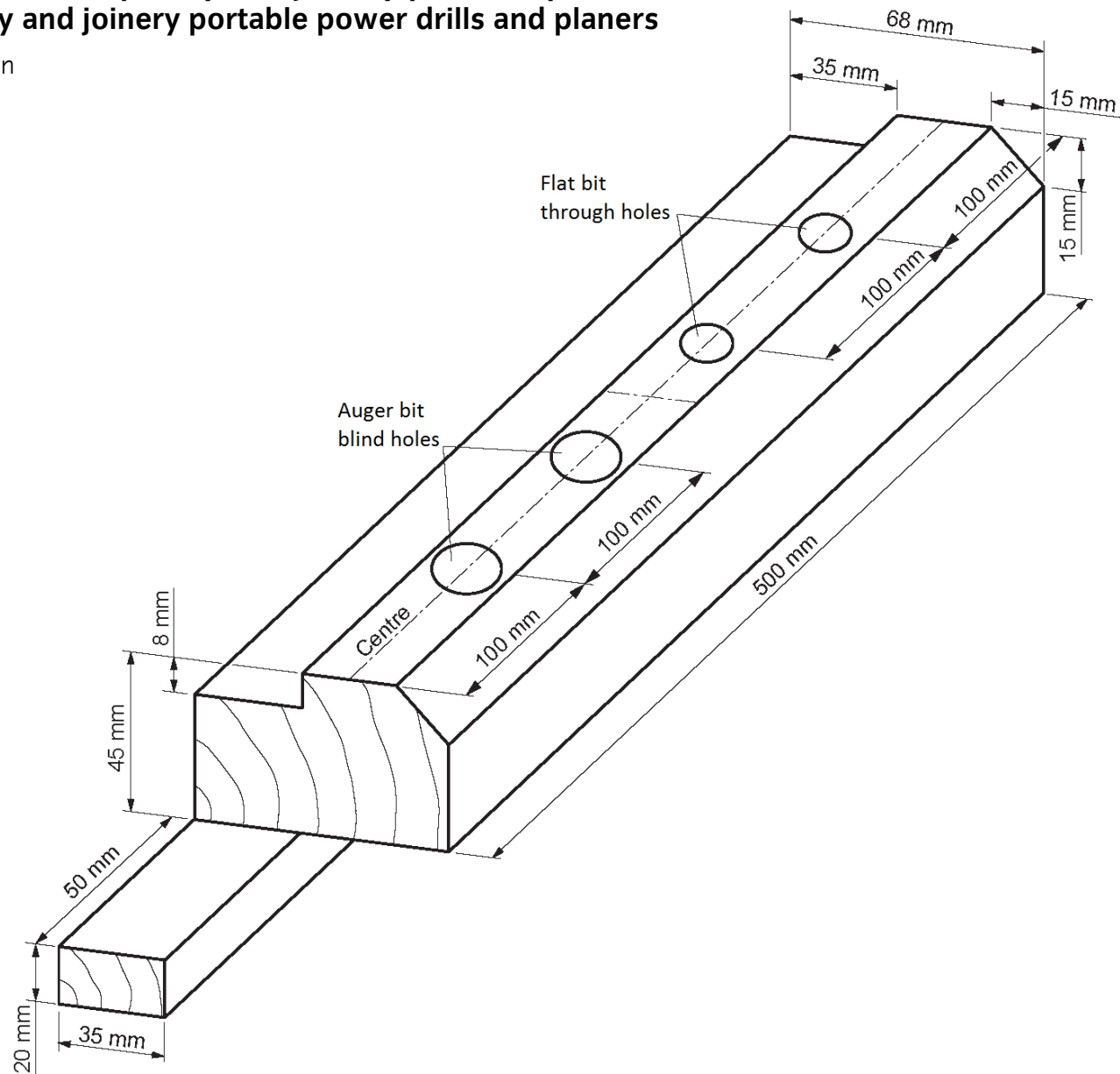

## Drawings and diagrams

### Unit 114 Prepare and use carpentry and joinery portable power tools

#### Task 2 Use carpentry and joinery portable power saws

Figure 1: Timber block for chopsaw

Diagram not to scale

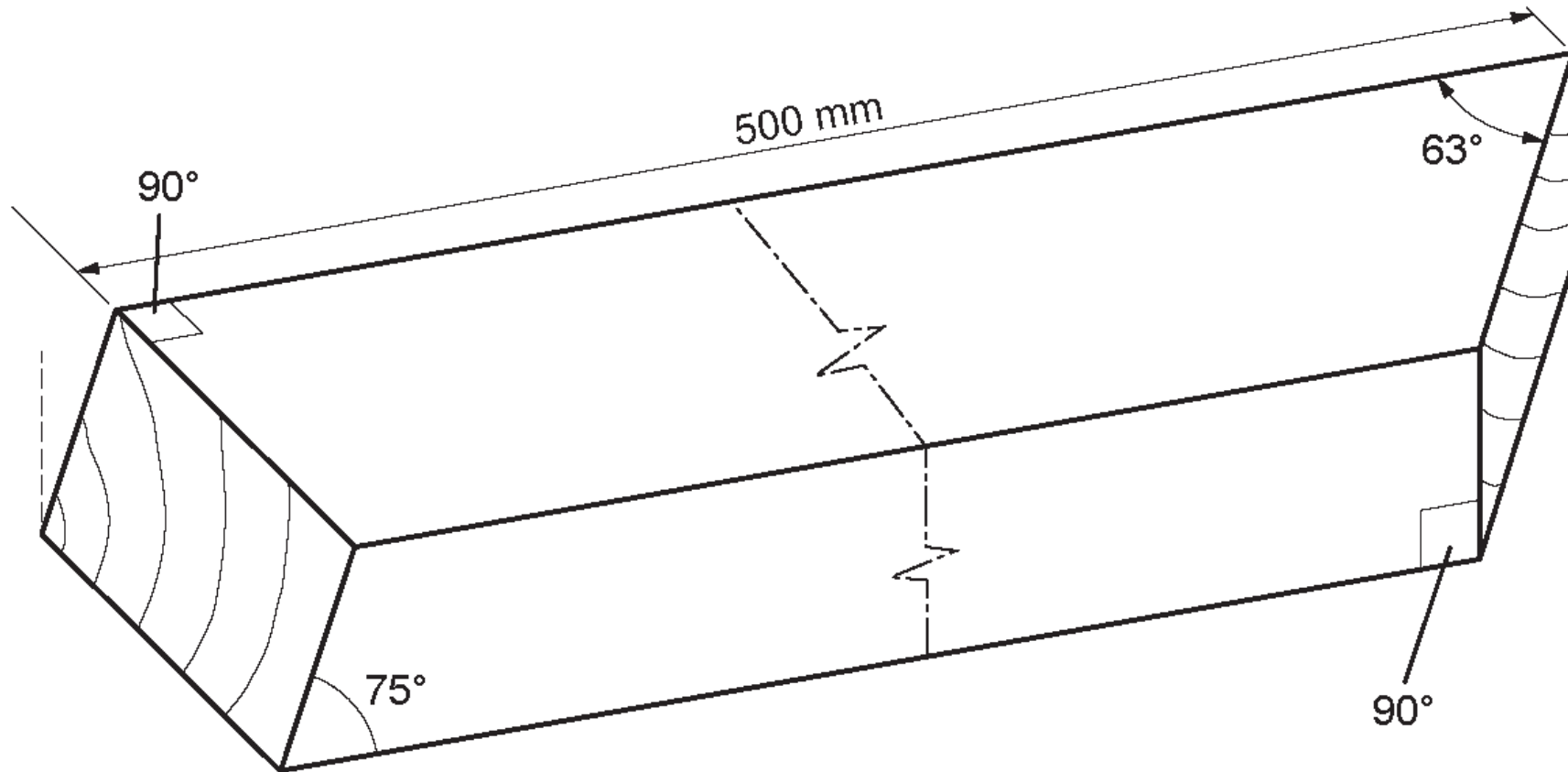

## Drawings and diagrams

### Unit 114 Prepare and use carpentry and joinery portable power tools

#### Task 2 Use carpentry and joinery portable power saws

Figure 2: Manufactured board for jigsaw

Diagram not to scale

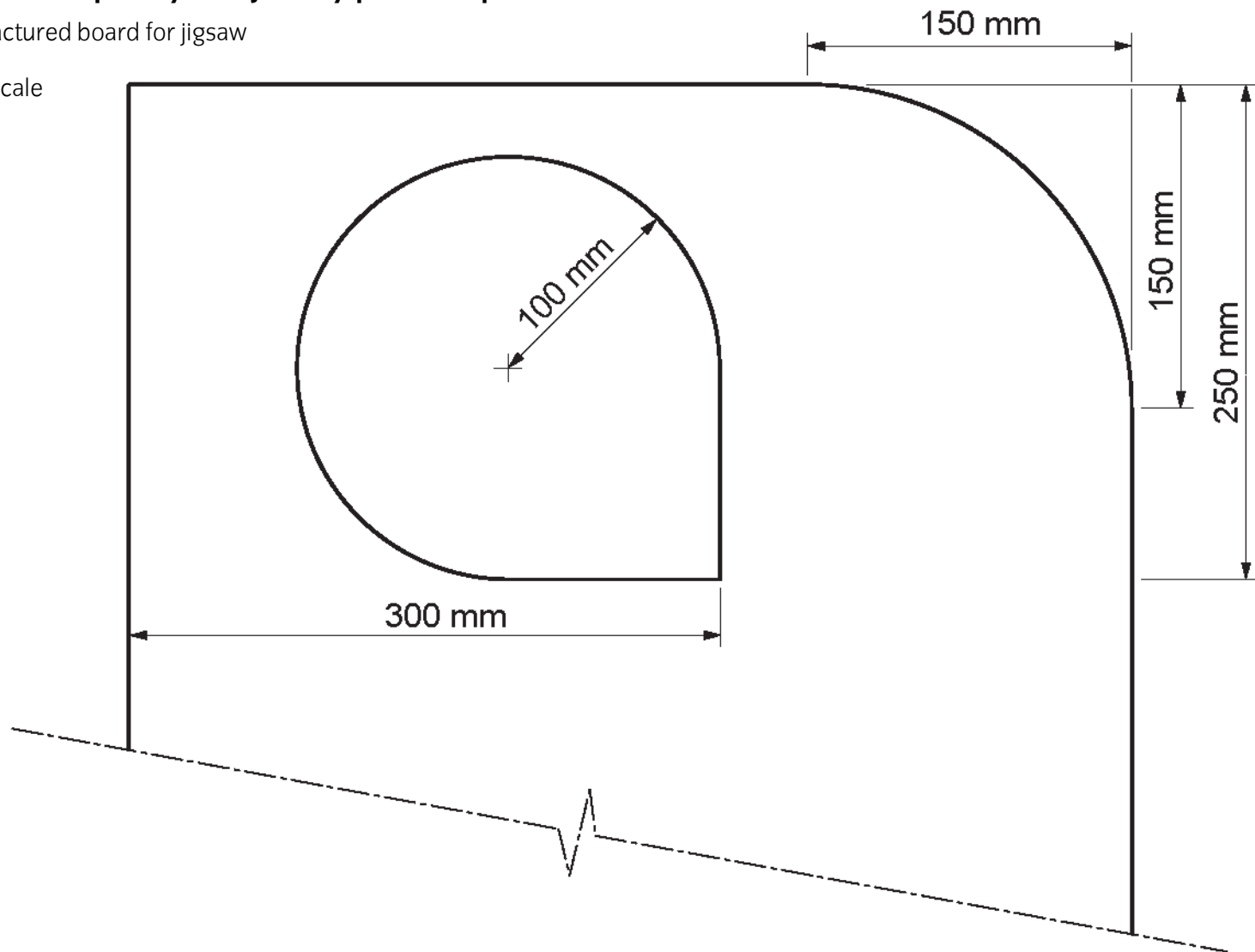

## Drawings and diagrams

### Unit 114 Prepare and use carpentry and joinery portable power tools

#### Task 3 Use carpentry and joinery portable power routers and sanders

Figure 1: Timber for router and sander

Diagram not to scale

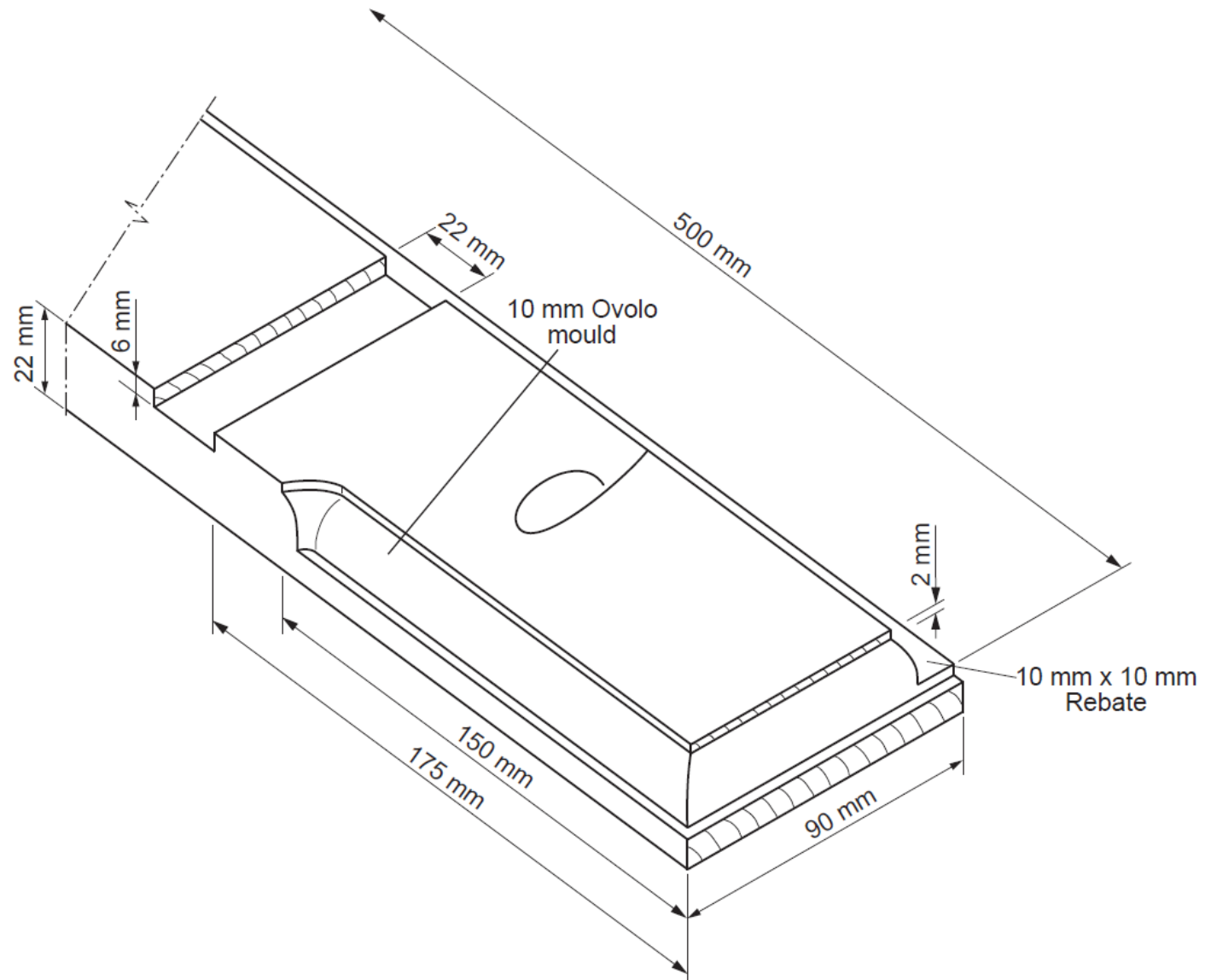

## Drawings and diagrams

### Unit 115 Produce woodworking joints

#### Task 1 Mark out woodworking joints

#### Task 2 Produce basic woodworking joints and form a frame

Figure 1: Frame

Diagram not to scale

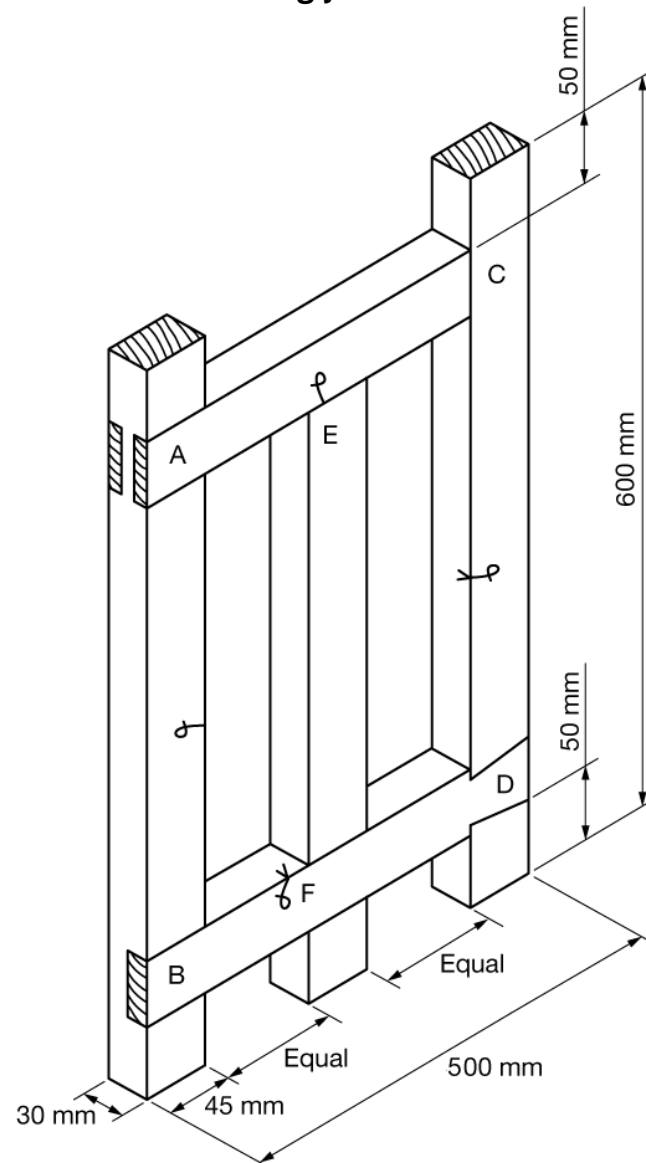

Secure joints A and B with two screws countersunk below the surface

Screws to be positioned 10 mm in from all edges

All materials 45 mm x 30 mm PAR

## Drawings and diagrams

### Unit 115 Produce woodworking joints

#### Task 1 Mark out woodworking joints

#### Task 2 Produce basic woodworking joints and form a frame

Figure 2: Tee bridle joint A

Diagram not to scale

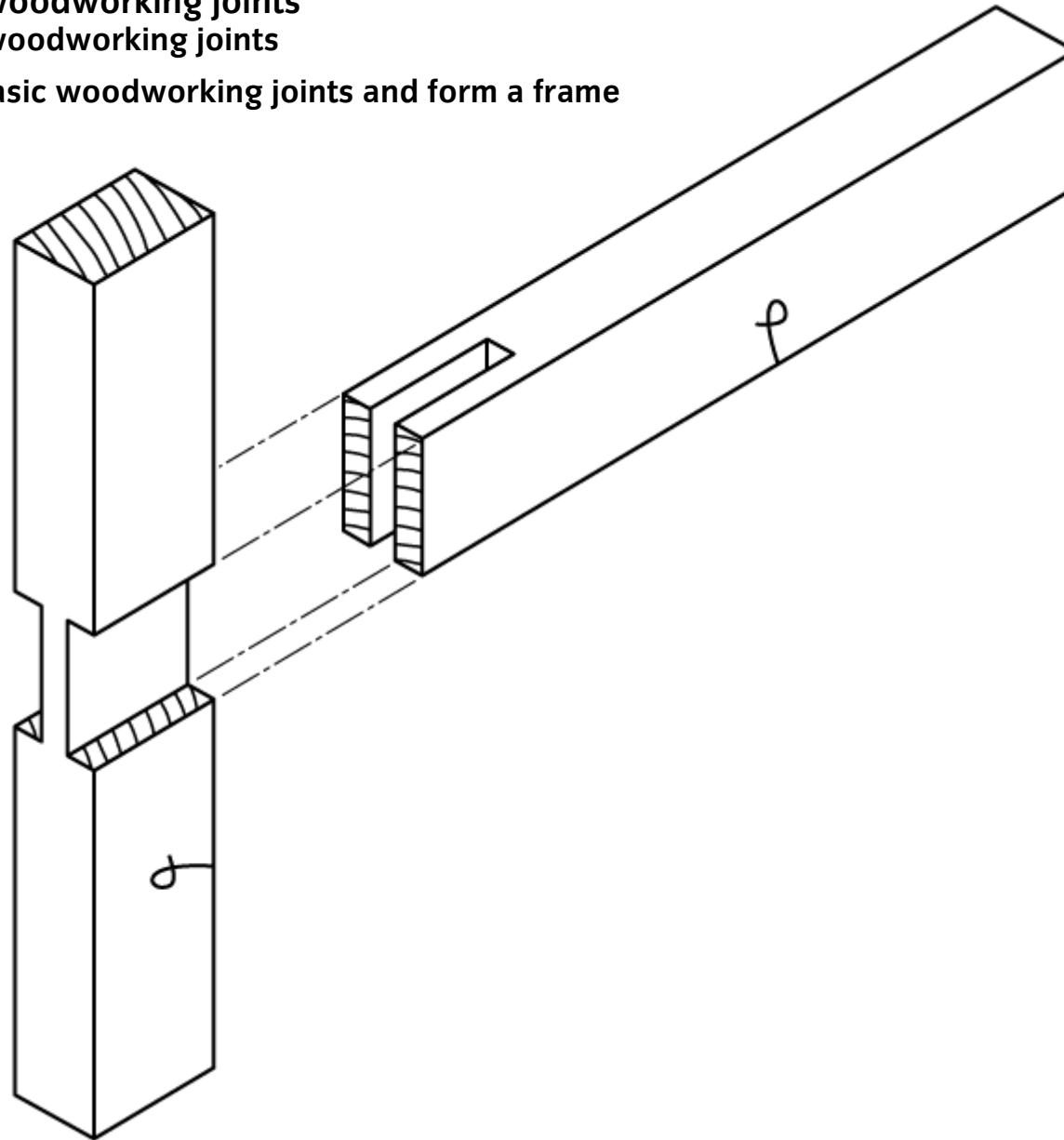

## Drawings and diagrams

### Unit 115 Produce woodworking joints

#### Task 1 Mark out woodworking joints

#### Task 2 Produce basic woodworking joints and form a frame

Figure 3: Tee halving joint B

Diagram not to scale

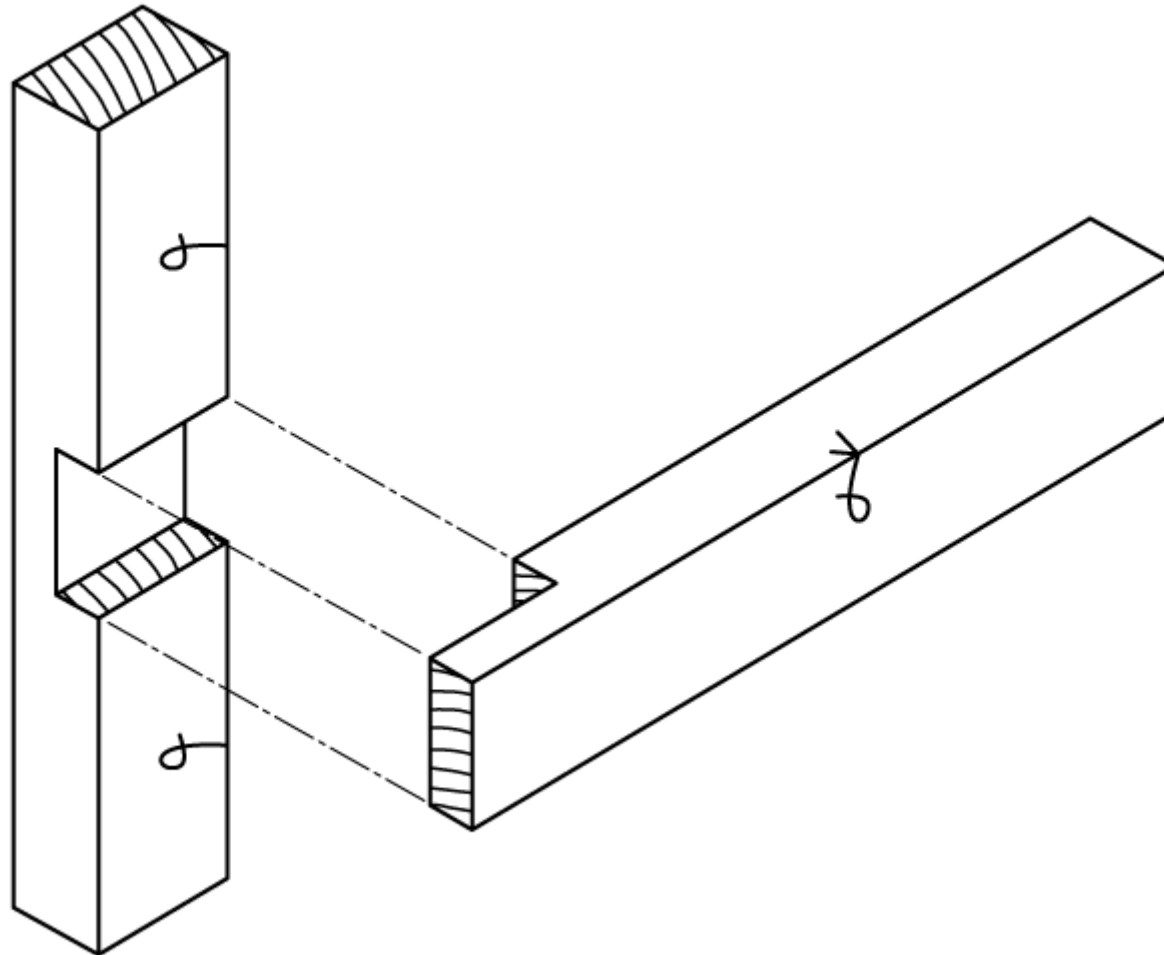

## Drawings and diagrams

### Unit 115 Produce woodworking joints

#### Task 1 Mark out woodworking joints

#### Task 2 Produce basic woodworking joints and form a frame

Figure 4: Mortice and tenon joint C

Diagram not to scale

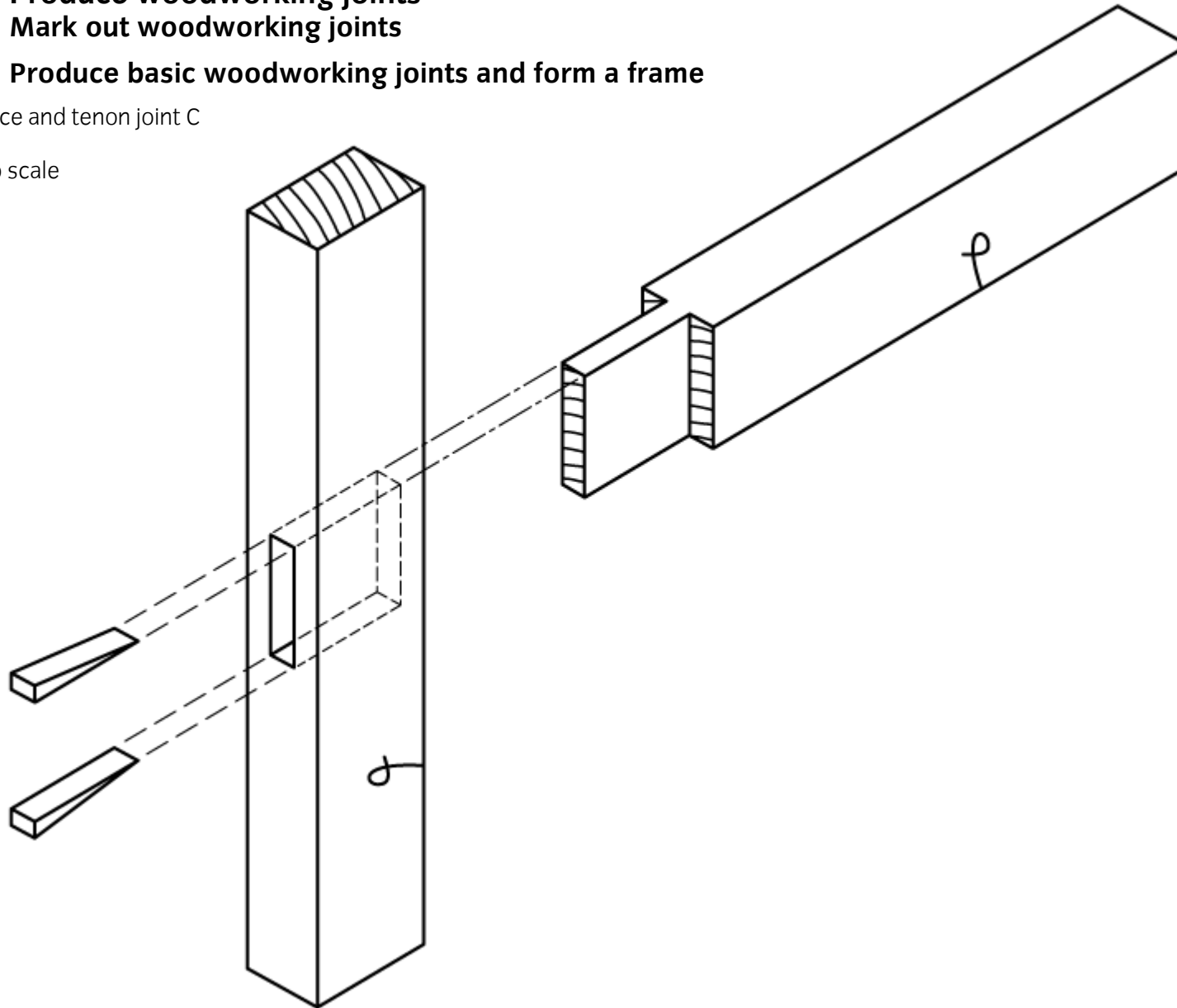



## Drawings and diagrams

### Unit 115 Produce woodworking joints

#### Task 1 Mark out woodworking joints

#### Task 2 Produce basic woodworking joints and form a frame

Figure 5: Dovetail halving joint D

Diagram not to scale

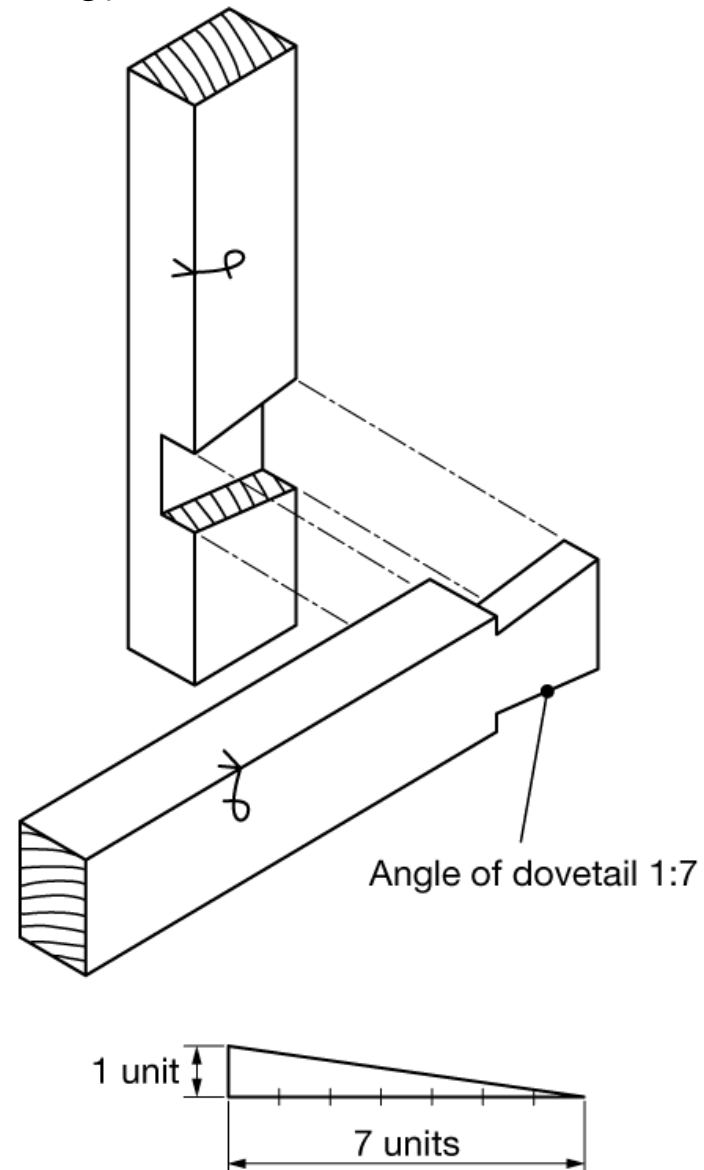

## Drawings and diagrams

### Unit 115 Produce woodworking joints

#### Task 1 Mark out woodworking joints

#### Task 2 Produce basic woodworking joints and form a frame

Figure 6: Stub mortice and tenon joint E

Diagram not to scale

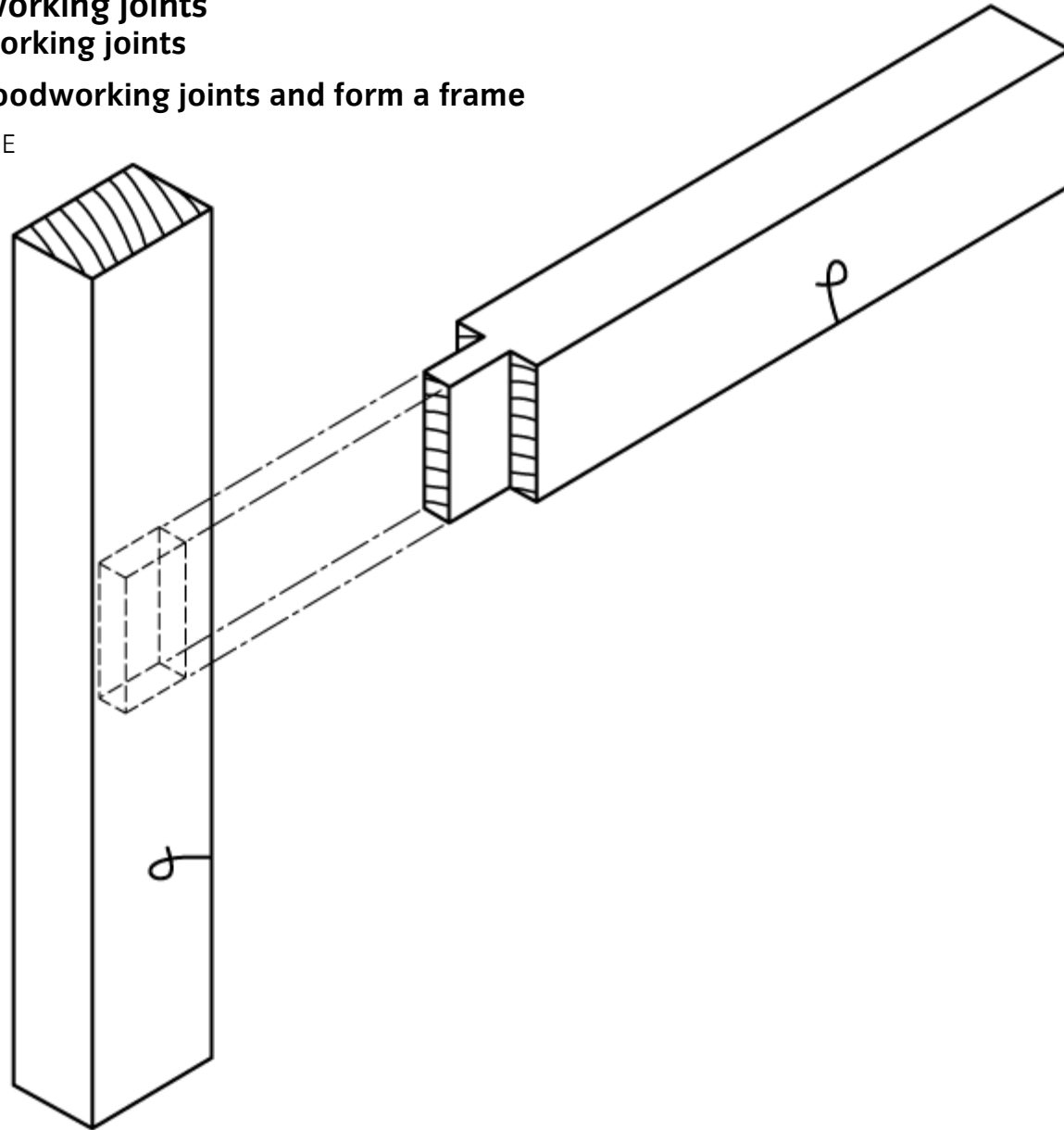

## Drawings and diagrams

### Unit 115 Produce woodworking joints

#### Task 1 Mark out woodworking joints

#### Task 2 Produce basic woodworking joints and form a frame

Figure 7: Cross halving joint F

Diagram not to scale

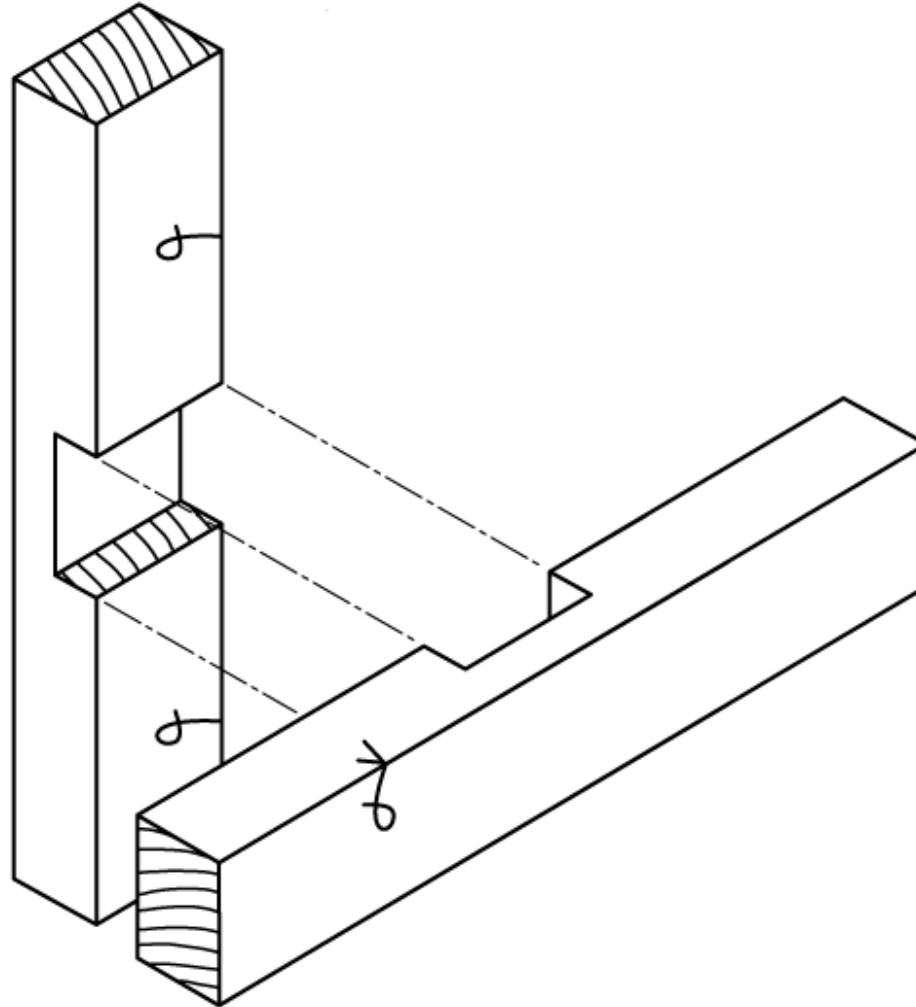

---

**Published by City & Guilds**  
**1 Giltspur Street**  
**London**  
**EC1A 9DD**  
**T +44 (0)844 543 0000**  
**F +44 (0)20 7294 2413**  
**www.cityandguilds.com**

**City & Guilds is a registered charity  
established to promote education  
and training**

#### **About City & Guilds**

As the UK's leading vocational education organisation, City & Guilds is leading the talent revolution by inspiring people to unlock their potential and develop their skills. We offer over 500 qualifications across 28 industries through 8500 centres worldwide and award around two million certificates every year. City & Guilds is recognised and respected by employers across the world as a sign of quality and exceptional training.

#### **City & Guilds Group**

The City & Guilds Group operates from three major hubs: London (servicing Europe, the Caribbean and Americas), Johannesburg (servicing Africa), and Singapore (servicing Asia, Australia and New Zealand). The Group also includes the Institute of Leadership & Management (management and leadership qualifications), City & Guilds Land Based Services (land-based qualifications), the Centre for Skills Development (CSD works to improve the policy and practice of vocational education and training worldwide) and Learning Assistant (an online e-portfolio).

#### **Copyright**

The content of this document is, unless otherwise indicated, © The City and Guilds of London Institute and may not be copied, reproduced or distributed without prior written consent. However, approved City & Guilds centres and candidates studying for City & Guilds qualifications may photocopy this document free of charge and/or include a PDF version of it on centre intranets on the following conditions:

- centre staff may copy the material only for the purpose of teaching candidates working towards a City & Guilds qualification, or for internal administration purposes
- candidates may copy the material only for their own use when working towards a City & Guilds qualification

The *Standard Copying Conditions* (see the City & Guilds website) also apply.

Published by City & Guilds, a registered charity established to promote education and training

Every effort has been made to ensure that the information contained in this publication is true and correct at the time of going to press. However, City & Guilds' products and services are subject to continuous development and improvement and the right is reserved to change products and services from time to time. City & Guilds cannot accept liability for loss or damage arising from the use of information in this publication.