



City & Guilds Level 2 Extended Technical Occupational Entry in Wood Occupations (Diploma) - Architectural Joinery (7255-62)

Version 1.1 (October 2025)

**Assignment Pack 7255-262
Candidate (sample)**

Version and date	Change detail	Section
V1.0 July 2025	Initial version	All
V1.1 October 2025	Task 3 updated with change of tooling requirement	4

Contents

1. Assessment overview	4
2 Assignment guidance	5
3. Assignment brief	7
4. Tasks	9
Task 1 – Resources list and risk assessment	9
Task 2 – Setting out	10
Task 3 – Practical project	11

1. Assessment overview

This assessment is for the Level 2 Extended Technical Occupational Entry in Wood Occupations (Diploma) – Architectural Joinery qualification. This pack consists of a practical assignment brief that you will need to use to complete your assessment tasks.

2 Assignment guidance

General guidance

Please read **ALL** information carefully before the assessment.

This is a formal assessment that you will be graded on. You will be graded on the quality and accuracy of the work you produce. It is therefore important that you carry out your work to the highest standard you can.

Plagiarism

Plagiarism is the failure to acknowledge sources properly and/or the submission of another person's work as if it were your own. Plagiarism is **not** allowed in this assignment.

This assignment is an assessment of your abilities, so the work submitted must be all your own and carried out under the conditions stated. You will be asked to sign a declaration that you have not had any help with the assignment. Your assessor is allowed to give you general advice, such as clarification of the task instructions. However, general advice will not include:

- any specific advice on how to improve work to meet the required standard
- feedback on anything missing from your work
- any intervention that improves the standard or presentation of work.

If there is a need to provide more than general advice, your assessor will need to record the advice they have given and take it into account when marking the submitted work.

Where research is allowed, your assessor must be able to identify which work you have done yourself and what you have found from other sources. It is therefore important to make sure you acknowledge sources used and clearly reference any information taken from them (eg providing, as a minimum, a list of web addresses, books, articles etc that you used).

Timings and planning

You are advised to study the details of the assessment before starting.

You should check with your assessor that you have all the relevant materials, equipment and information/data sources that you need before starting the assessment.

You should take care when planning to make sure you have divided the time available between parts of the assignment tasks appropriately. Timings for tasks are provided within this pack to support with planning and time allocation.

If you have a good reason for needing more time, you will need to explain the reasons to your assessor and agree a new time for the assessment to take place. Any changes will be at the discretion of the assessor and agreed by City & Guilds.

Health and safety

You must always work safely while you are carrying out practical tasks.

You must always follow any relevant health and safety regulations, risk assessments and codes of practice in line with centre requirements.

If your assessor sees you working in a way that is unsafe for yourself or others, they will highlight the issue and ask you to stop the task immediately.

Presentation of work

Presentation of work must be neat and legible. It must be appropriate to the task and to the evidence required for submission.

You should make sure that each piece of evidence, including any forms, are clearly labelled with your name and the project reference.

Calculations should be set out clearly, with all workings shown, as well as any assumptions made. You should use appropriate units at all times, consistent with the requirements of the assignment.

Instructions for this assignment

Ensure you read all the provided assessment information issued by the assessor.

You must work independently and not share your work with any other candidates in these supervised assessment sessions.

Your work will be kept secure during any supervised breaks that are taken.

Internet access is **not** allowed, unless otherwise stated in the task.

You will not be permitted any additional notes, such as printed resources and textbooks, unless otherwise stated in the conditions for assessment.

You must complete all the tasks and present all evidence that is detailed in each task. This candidate pack contains the assignment brief.

Any additional documents/templates needed for the task will be provided to you by the assessor.

Within each task you will find the following:

- **Resources:** This provides a list of equipment, documents or tools that you will have access to in order to complete the task.
- **Conditions of assessment:** This will tell you the duration and rules you must follow when completing a task.
- **Controlled conditions:** This will tell you the rules you must follow when completing each task. For example, you must not share or discuss your work with other candidates.
- **What must be produced for marking:** This describes the evidence you must submit when the task is completed. Be aware that failure to submit any evidence requested can adversely affect your overall mark for the assessment.
- **Additional evidence for this task:** This describes other forms of evidence that will be collected by the assessor to support the marking of your performance. This will often include, but is not limited to, photographic and video evidence.

3. Assignment brief

You are working on bench joiner for Craft Unlimited, a joinery company that specialises in producing bespoke items.

A client wishes to have a short flight of stairs manufactured for their home. You have been requested to set out and produce the flight of stairs shown in the drawings provided.

(Note: stair dimensions shown on the drawings have been reduced to 4/5ths of full size for assessment purposes.)

Specification

The flight of stairs is to be made as in Drawings 1 and 2 provided below.

Drawing 1

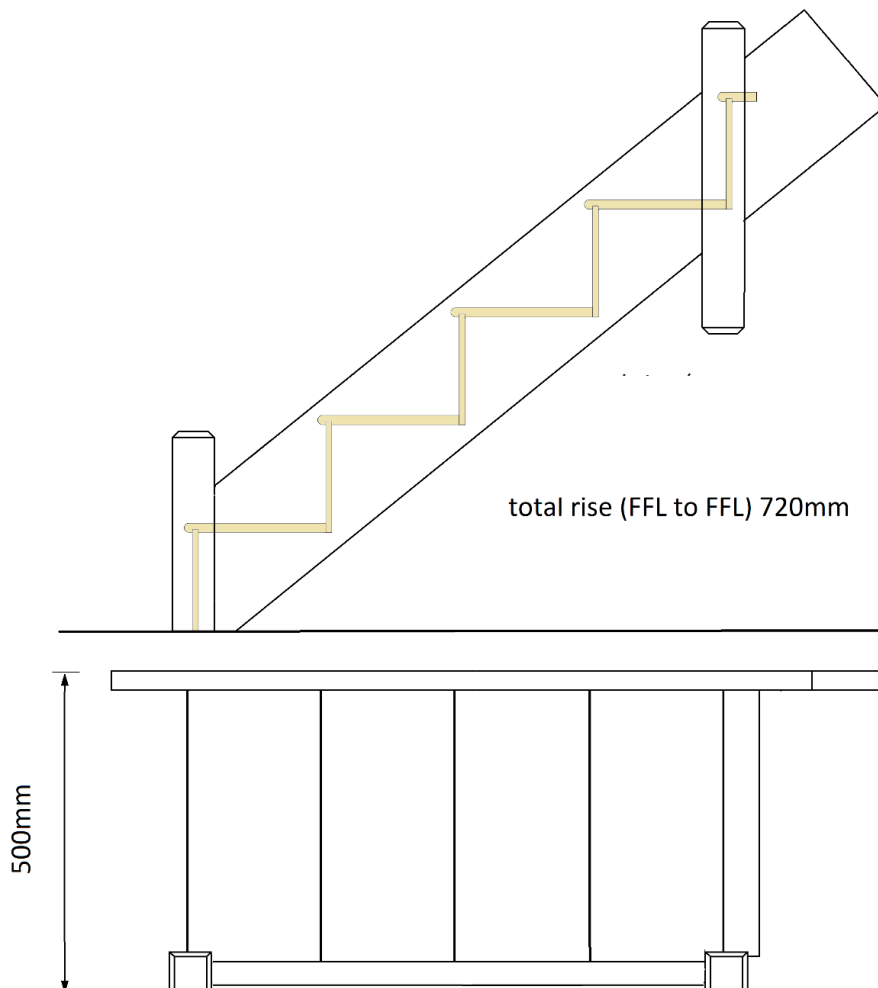

Drawing 2

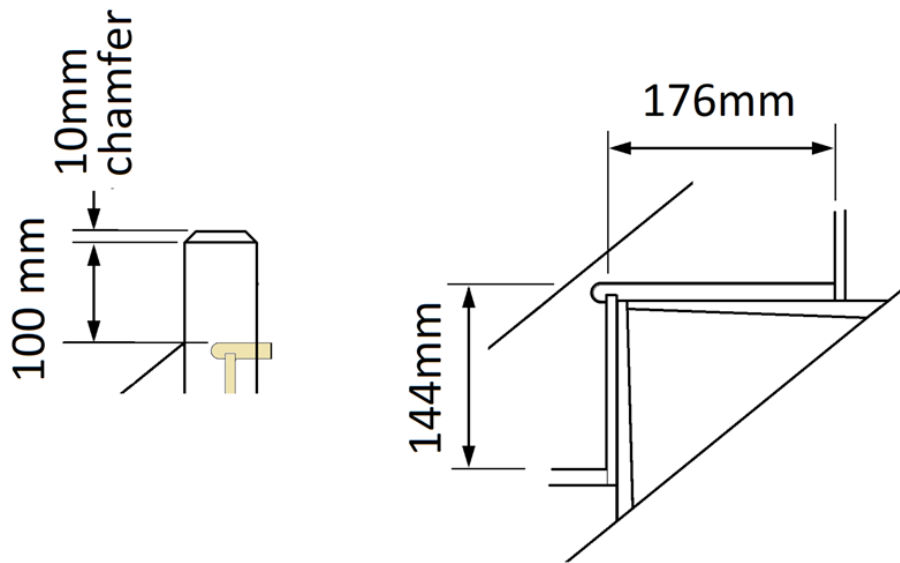

The margin is 28mm and the nosing is 16mm.

Finished newel size is 69mm x 69mm x 500mm.

Material specification:

- String material: 195mm x 32mm planed all round (PAR) whitewood.
- Newel material @ 69mm x 69mm redwood.
- Tread Material: 18mm medium-density fibreboard (MDF).
- Top nosing: 70mm x 18mm PAR redwood.
- Riser material: 9mm plywood.
- Pre-made wedges for assembly.
- Dowel for draw-boring of newels to string.

This assignment has an overall time allocation of **14 hours**.

4. Tasks

Task 1 – Resources list and risk assessment

You should refer to the brief and technical information provided and then do the following:

1. Produce and complete a risk assessment covering all activities in Task 3.
2. Create a resources list of for Task 3. This should include:
 - cutting and materials
 - tools and equipment:
 - dividers
 - roofing/steel square
 - fence.

Resources

- Risk assessment form.
- Resources list.

Conditions of assessment

- The time allocated for this task is 2 hours.
- You must carry out the task on your own, under controlled conditions while being observed.

Controlled conditions

- You must work on your task in the allocated time only.
- Assessment evidence must be handed in at the end of each session for secure storage.
- You must not share or discuss your work with other candidates.
- You are not permitted to bring any materials into the assessment session.

What must be produced for grading

- Completed risk assessment for Task 3.
- Completed cutting and resource list.

Additional evidence for this task

- N/a

Task 2 – Setting out

Refer to the brief and technical information provided, and then do the following:

1. Set out outer string, including joint details at each end.

Resources

- Setting out equipment (e.g. dividers, roofing/steel square, fence).

Conditions of assessment

- The time allocated for this task is 2 hours.
- You must carry out the task on your own, under controlled conditions while being observed.

Controlled conditions

- You must work on your task in the allocated time only.
- Assessment evidence must be handed in at the end of each session for secure storage.
- You must not share or discuss your work with other candidates.
- You are not permitted to bring any materials into the assessment session.

What must be produced for grading

- Fully set out outer string that demonstrates correct measurement and calculation.

Additional evidence for this task

- Completed section of Assessor Observation Form (AOF).
- Two assessor photographs, one capturing the task in progress and the other at completion. The second photograph should show the fully set out outer string. The photographs can support judgements of quality which could affect the pass/fail decision.

Task 3 – Practical project

You are now required to make the components and assemble and finish the stairs, using the setting out details from Task 2.

You must do the following:

1. produce components for the stairs, using hand tools, power tools and machines
2. change tooling on a woodworking machine as directed by your assessor
3. assemble the stairs
4. finish the stairs
5. work in a safe manner and segregate waste resources for reuse, recycling and disposal.

Resources

- The centre's risk assessments and method statements.
- Completed resource list from Task 1.
- Materials and equipment for producing components for the stairs, assembly and finishing:
 - workshop bench
 - machines
 - timber and fixing as provided
 - hand and power tools.
- Appropriate personal protective equipment (PPE).

Conditions of assessment

- This is a workshop-based assessment, to be carried out individually and under controlled conditions.
- The time allocated for this task is 10 hours (not including waiting or curing time).
- You must carry out the task on your own, under controlled conditions while being observed.

Controlled conditions

- You must not share or discuss your work with other candidates.
- You must work on your task in the allocated time only.
- You are permitted to use only the reference materials detailed above in the resources section.
- You must complete the task under supervision with no assistance.

What must be produced for grading

- Completed stairs.

Additional evidence that may be captured for grading for this task

- Completed section of AOF.
- Two assessor photographs, capturing the task in progress and at completion:
 - the first photograph must show the assembly.
 - the second photograph must show the completed stairs.
- The photographs can support judgements of quality which could affect the pass/fail decision.