



7906-507 JUNE 2018
Level 2 Technical Certificate in Site Carpentry
Level 2 Site Carpentry – Theory exam

Wednesday 20 June 2018
09:30 – 11:30

You should have the following for this examination

- a multiple-choice answer sheet
- a pen with black or blue ink
- non-programmable calculator

This question paper is the property of City & Guilds Limited and is to be returned after the examination.

Read the following notes before you answer any questions

- You **must** use a pen with black or blue ink to complete **all** parts of the answer sheet.
- Check that you have the correct answer sheet for the examination.
- Check that your name and candidate details are printed correctly at the top of your answer sheet.
- Inform the invigilator if your name or examination details are not correct.
- Each question shows **four** possible answers (lettered 'a', 'b', 'c' and 'd'); only **one** is correct.
- Decide which **one** is correct and mark your answer on the **answer sheet** with your pen.

For example if you decide 'a' is correct, mark your answer like this

101 (a) (b) (c) (d)

If you want to change your answer, cancel your first choice by filling in the 'cancel' box below the circle like this

101 (a) (b) (c) (d)

Then mark the answer which you have now decided is correct. For example if you now decide 'c' is correct, mark your answer like this

101 (a) (b) (c) (d)

Any other marks on the form may invalidate some of your answers.

- Any calculations or rough working can be done on the question paper.
- Attempt all questions. If you find a question difficult, leave it and return to it later.

This paper contains 60 questions. Answer them using the 'boxes' numbered 1 to 60 on the answer sheet.

Please note that this theory test has been amended to ensure it is fit for purpose for use as a sample assessment.

- 1 What is the **best** method of reinforcing health and safety information on a building site?
- a Text.
 - b Email.
 - c Memo.
 - d Signage.

- 2 Which is **not** a contract document?
- a Tender form.
 - b Time sheet.
 - c Schedule of work.
 - d Bill of Quantities.

- 3 An employee is off work for seven days or more following an accident at work. Which legislation requires it **must** be reported?
- a RIDDOR.
 - b COSHH.
 - c PUWER.
 - d LOLER.

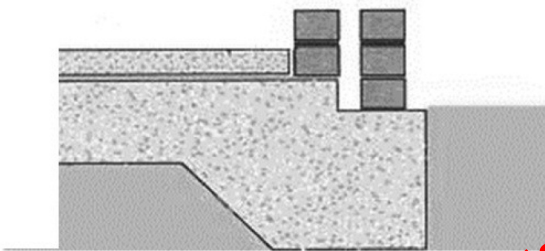

Figure 1

- 4 What type of foundation is shown in Figure 1?
- a Pad.
 - b Strip.
 - c Pile.
 - d Raft.
- 5 Which is **not** classed as a building service?
- a Gas supply.
 - b Electricity supply.
 - c Waste collection.
 - d Communication networks.

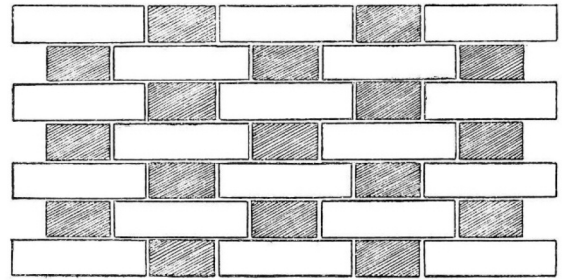

Figure 2

- 6 What brick bond is shown in Figure 2?
- a Header.
 - b Flemish.
 - c Stetcher.
 - d English
- 7 What type of wall supports suspended timber ground floor joists mid-span?
- a Cavity.
 - b Solid.
 - c Sleeper.
 - d Parapet.

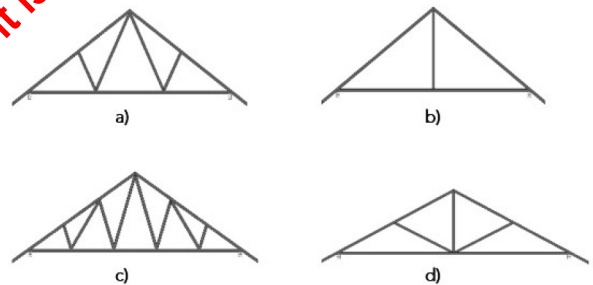

Figure 3

- 8 Which truss is known as a fink in Figure 3?
- a a)
 - b b)
 - c c)
 - d d)
- 9 Which activity is carried out prior to plastering?
- a Hanging internal doors.
 - b Fitting kitchen units.
 - c Erecting partition walls.
 - d Installing sanitary ware.

- 10 Who is responsible for ensuring that the quality of on-going work meets the requirements of the specification?
- Building Inspector.
 - Building Contractor.
 - Clerk of Works.
 - Site Clerk.
- 11 What type of drawing would provide the information required to set out some internal stud work?
- Floor plan.
 - Location plan.
 - Planning drawing.
 - Assembly drawing.
- 12 Which is a control measure of the working at height regulations?
- Only work at height during the hours of daylight.
 - Avoid work at height where it's reasonably practicable to do so.
 - Avoid working on tower scaffolds with access traps.
 - Only wear PPE if the working platform hasn't been inspected.
- 13 What areas of welfare **must** be provided on site?
- Water, smoking room, vending machine.
 - Toilets, water, vending machine.
 - Washing, toilets, drying room.
 - Smoking room, toilets, drying room.
- 14 Which two components are rafter rafters fixed between?
- Wall plate and valley.
 - Wall plate and hip.
 - Ridge and hip.
 - Valley and cripple.
- 15 What method is used to prevent 'wind lift' of a roof according to Building Regulations?
- According to Part A, rafters must be screwed to the wall-plate.
 - According to Part A, wall-plates must be strapped to load bearing walls.
 - According to Part B, rafters must be screwed to the wall-plate.
 - According to Part B, wall-plates must be strapped to load bearing walls.
- 16 When setting up for new site within a busy shopping precinct, what would be the **best** method to protect the general public from the planned construction work?
- Chain link fencing, because this provides the best barrier.
 - Solid hoarding, because this provides the best barrier.
 - Erect signage, to direct public away from the construction work.
 - Security patrols, to direct public away from the construction work.
- 17 A steel framework building is to be erected with a non-load bearing decorative block external skin. What are the two best foundation options?
- Raft and strip.
 - Raft and pad.
 - Pad and strip.
 - Pad and pile.
- 18 During the planning of a new detached property the client has request a usable cellar be incorporated into the design. What method of ground floor construction is required between the cellar and the ground floor?
- Reinforced concrete over hardcore.
 - Solid concrete with DPM.
 - Block and beam with screed.
 - 100 mm x 50 mm joist over sleeper walls.

Please note that this theory test has been amended to ensure it is fit for purpose for use as a sample assessment.

19 Using commercially available lengths of timber, calculate how many 100 mm x 50 mm sawn studs will be needed for a partition using the following information.

- partition size 2.8 x 4.6
- studs at 400 mm centres

- a 13 x 2.8 m studs.
- b 13 x 3 m studs.
- c 14 x 2.8 m studs.
- d 14 x 3 m studs.

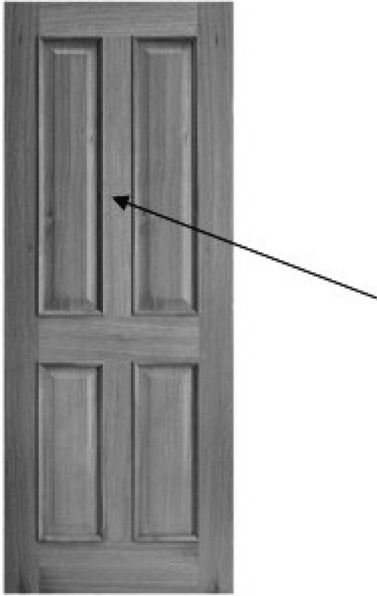

Figure 4

20 What is the term given to the component indicated by the arrow in Figure 4?

- a Stile.
- b Rail.
- c Jamb.
- d Muntin.



Figure 5

21 What type of lock set is shown in Figure 5?

- a Night latch.
- b Dead lock.
- c Rim lock.
- d Mortise latch.



Figure 6

22 What type of saw is shown in Figure 6?

- a Tenon.
- b Dovetail.
- c Coping.
- d Panel.



Figure 7

23 What operation can be performed using the router jig shown in Figure 7?

- a Morticing for locks.
- b Recessing for hinges.
- c Jointing worktop.
- d Cutting apparatus.

Please note that this theory test has been amended to ensure it is fit for purpose for use as a sample assessment.



Figure 8

24 What type of moulding is shown in Figure 8?

- a Dado rail.
- b Picture rail.
- c Cornice.
- d Plinth.

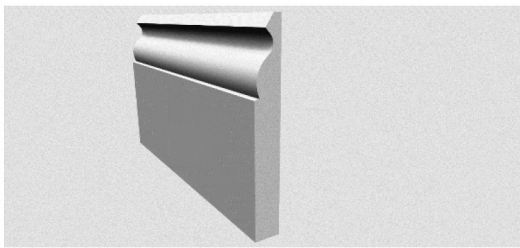

Figure 9

25 What moulding profile is shown on the skirting board in Figure 9?

- a Torus.
- b Ovolo.
- c Ogee.
- d Cove.

26 What tool will **best** transfer a datum line around a room?

- a Spirit level.
- b Water level.
- c Laser level.
- d Line level.

27 What joint is used to connect two lengths of skirting boards on a straight run?

- a Mitre.
- b Scarf.
- c Scribe.
- d Heading.

28 What is required to support thin facing material, when casing in pipes?

- a Metal brackets.
- b Fixing blocks.
- c Glue and screws.
- d Skeleton framework.

29 What facing material is **best** used for pipe casing within a bathroom?

- a Hardboard.
- b Plasterboard.
- c PVC cladding.
- d OSB cladding.

30 What saw is **most** suitable to cut facing material around pipe work?

- a Gents.
- b Tenon.
- c Coping.
- d Crosscut.

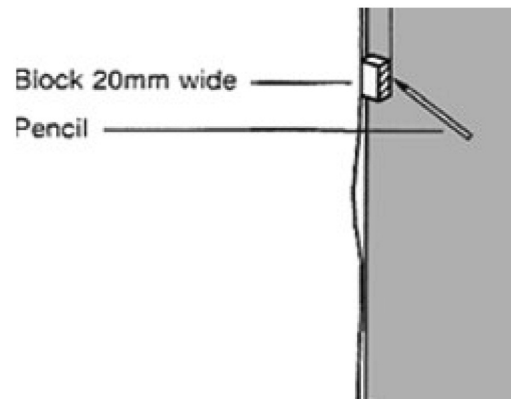

Figure 10

31 What operation is being carried out in Figure 10?

- a Shooting.
- b Scribing.
- c Shaping.
- d Sanding.

Please note that this theory test has been amended to ensure it is fit for purpose for use as a sample assessment.



Figure 11

32 What type of worktop is shown in Figure 11?

- a Granite.
- b Composite.
- c Solid timber.
- d Post formed.

33 When fitting wall units to a plasterboard faced stud work, which fixing is **best** used?

a



b



c



d



34 What power tool is **best** used to form the internal mitred joint on a kitchen worktop?

- a Router.
- b Jigsaw.
- c Circular saw.
- d Reciprocating saw.

35 What jointing method is used to connect kitchen worktops?

- a Biscuits and toggles.
- b Biscuits and bolts.
- c Bolts and plates.
- d Toggles and plates.

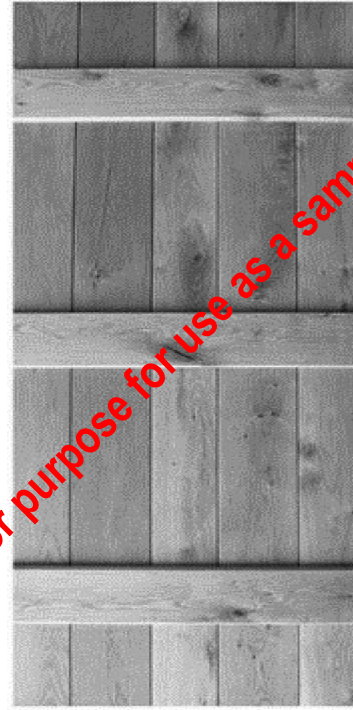

Figure 12

36 What component is added to the door in Figure 12, to prevent the leading edge dropping under its own weight?

- a Strut.
- b Binder.
- c Braces.
- d Ledges.

37 An existing door is fitted with a night latch, for additional security what ironmongery is **best** fitted?

- a Hinge bolt and dead lock.
- b Hinge bolt and mortice latch.
- c Security chain and mortice latch.
- d Spy hole and privacy lock.

Please note that this theory test has been amended to ensure it is fit for purpose for use as a sample assessment.

- 38 What is the second stage in the sequence for fitting an internal door?
- Shoot door.
 - Fit locks.
 - Fix stops.
 - Chop hinges.



Figure 13

- 39 When fitting cornice to the open corner unit shown in Figure 13, what angle would the chop saw be set to?
- 17.5
 - 22.5
 - 30
 - 45
- 40 When fitting architrave what is the recommended margin between the frame and the architrave, so as to not interfere with the hinge knuckle and the lock keep?
- 1-3 mm.
 - 5-7 mm.
 - 10-12 mm.
 - 14-16 mm.

- 41 What design features would be incorporated into a service encasement containing a soil stack?
- Insulation and acoustic cladding material.
 - Insulation and foil backed plasterboard.
 - Metal stud and foil backed plasterboard.
 - Metal stud and moisture resistant board.

- 42 Why does the Building Regulations require that steel beams are encased in a domestic building?

- To ensure structural fire protection.
- To improve the finished appearance.
- To hide the supporting structure.
- To ensure clean lines for decorating.

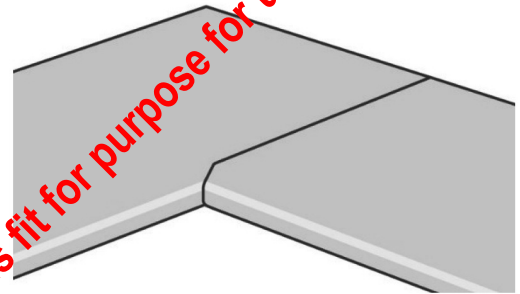

Figure 14

- 43 When routing the male cut as shown in Figure 14, how should the worktop be positioned?
- Face up cutting from the face edge.
 - Face down cutting from the face edge.
 - Face up cutting from the back edge.
 - Face down cutting from the back edge.
- 44 What is the **first** action to take prior to hanging a front door on a large development?
- Refer to the door schedule for information.
 - Obtain requisition for ironmongery.
 - Collect resources from store.
 - Refer to manufacturer's information.

Please note that this theory test has been amended to ensure it is fit for purpose for use as a sample assessment.

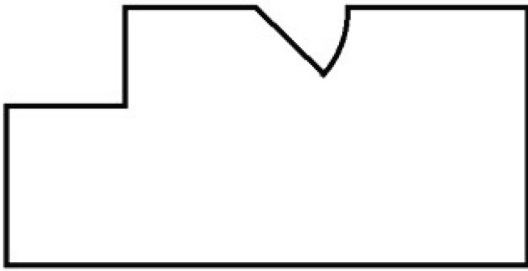

Figure 15

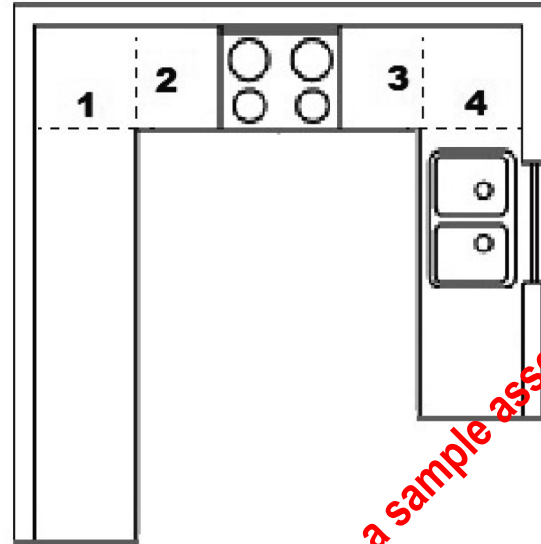

Figure 16

- 45 How many 4.5 m lengths of skirting board will be required for the room shown in Figure 15, do not allow for waste.

Room data

Length: 5.3 m

Width: 3.2 m

Door opening: 0.9 m

- a 3
b 4
c 5
d 6
- 46 What is the **best** method of fixing oak mouldings that are to receive a clear varnish finish?
- a Contact adhesive and pinned.
b Cut nailed and wax filled.
c Nailed and pelleted.
d Screwed and pelleted.
- 47 A soil pipe runs vertically in the corner of a kitchen, what boxing in method is **best** used when a skimmed finish is required?
- a 18 mm MDF with air gap.
b 18 mm MDF with loose fill insulation.
c Timber frame, air gap and plasterboard.
d Timber frame, loose insulation and plasterboard.

- 48 Where should the joints for the worktop, shown in Figure 16, be positioned?

- a 1 and 3
b 2 and 3
c 1 and 4
d 2 and 4.

- 49 What is OSB an abbreviation for?

- a Ordinary straw board.
b Oriented straw board.
c Ordinary strand board.
d Oriented strand board.

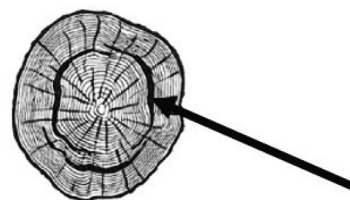

Figure 17

- 50 What type of shake is indicated by the arrow shown in Figure 17?

- a Star.
b Cup.
c Heart
d Thunder.

Please note that this theory test has been amended to ensure it is fit for purpose for use as a sample assessment.

51 Which legislation specifically covers the safe use of woodworking machines?

- a LOLER.
- b PUWER.
- c COSHH.
- d RIDDOR.

52 What part of the body can be subjected to potential long-term harm if a circular saw has inadequate extraction?

- a Eyes.
- b Kidney.
- c Lungs.
- d Ears.



Figure 18

53 What type of circular saw is shown in Figure 18?

- a Radial arm.
- b Dimensioning.
- c Rip.
- d Chop.

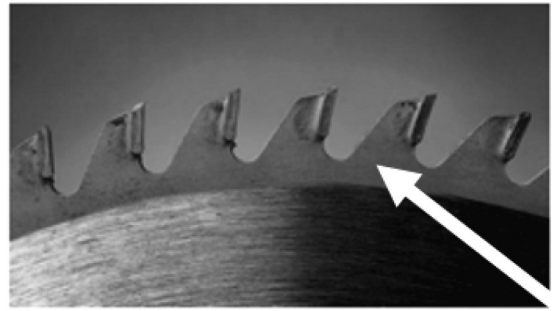

Figure 19

54 What part of the saw blade is indicated by the arrow in Figure 19?

- a Hook.
- b Gullet.
- c Root.
- d Heel.

55 What is the recommended moisture content of timber used for internal joinery?

- a 4-7%
- b 8-13%
- c 14-20%
- d 21-25%

56 What saw would be **best** used to cut a quantity of tilting fillets?

- a Narrow band.
- b Wall.
- c Cross cut.
- d Rip.

57 Why **must** the riving knife be 10% thicker than the gauge of the saw blade?

- a To hold the timber against the fence.
- b To prevent the timber being cut from binding on the back of the saw blade.
- c To ensure the timber is cut straight.
- d To prevent the timber from twisting during the cutting process.

Please note that this theory test has been amended to ensure it is fit for purpose for use as a sample assessment.

- 58 Where should the fence be set in relation to the saw blade when ripping timber?
- a In line with the gullets at the back of the saw blade.
 - b In line with the tips of the teeth at the back of the saw blade.
 - c In line with the gullets at the front of the saw blade.
 - d In line with the tips of the teeth at the front of the saw blade.

- 60 How should the saw blade be set when ripping timber?
- a Set blade height to half-timber thickness, push through turn over and repeat.
 - b Set blade to maximum height and push timber through.
 - c Set blade so that only the teeth project above the timber surface and push through.
 - d Set blade to maximum height and cut from both ends into the centre.

59 If a table saw has a maximum blade size of 500 mm, calculate the **minimum** blade size that is allowed while maintaining a peripheral speed suitable to still cut efficiently.

- a 250 mm
- b 300 mm
- c 350 mm
- d 400 mm

Please note that this theory test has been amended to ensure it is fit for purpose for use as a sample assessment.

HOW GO BACK AND CHECK YOUR WORK

- **IMPORTANT -**
Are the details at the top of the answer sheet correct?
Have you filled in your answers in INK in the appropriate boxes on the answer sheet?