

Level 2 Technical Certificate in Plastering - Solid (7908-20)

Synoptic Assignment 2019 v1.0

PAST ASSIGNMENT (2019) - DO NOT USE FOR LIVE ASSESSMENT

General guidance for candidates

General guidance

This is a formal assessment that you will be marked and graded on. You will be marked on the quality and accuracy of your practical performance and the written work you produce. It is therefore important that you carry your work out to the highest standard you can. How well you know and understand the subject, and how you have used your knowledge and skills together to complete the tasks must be clear to the marker. This means you will have to explain your thinking and the reasons behind the way you have carried out the tasks and how/why you have made your decisions within your written work eg as part of your planning, reflections, or evaluations.

Plagiarism

This is an assessment of your abilities, so the work must be all your own work and carried out under the conditions stated. You will be asked to sign a declaration that you have not had any help with the assessment.

Your tutor is allowed to give you some help understanding the assignment instructions if necessary, but they will record any other guidance you need and this will be taken into account during marking.

Plagiarism is the failure to acknowledge sources properly and/or the submission of another person's work as if it were your own. Plagiarism is not allowed in this assignment.

Where research is allowed, your tutor must be able to identify which work you have done yourself, and what you have found from other sources. It is therefore important to make sure you acknowledge all sources and clearly reference any information taken from them.

Timings and planning

Where you have to plan your time, you should take care to make sure you have divided the time available between tasks appropriately. In some assignments, there are specified timings which cannot be changed and which need to be taken into account. You should check your plan is appropriate with your tutor.

If you have a good reason for needing more time, you will need to explain the reasons to your tutor and agree a new deadline date. Changes to dates will be at the discretion of the tutor, and they may not mark work that is handed in after the agreed deadlines.

Health and Safety

You must always work safely, in particular while you are carrying out practical tasks.

You must always follow any relevant Health and Safety regulations and codes of practice.

If your tutor sees you working in a way that is unsafe for yourself or others, they will ask you to stop immediately, and tell you why. Your tutor will not be able to continue the assessment until they are sure you are ready for assessment and can work safely.

Presentation of work

Presentation of work must be neat, legible and appropriate to the task.

You should make sure that each piece of evidence including any forms are clearly labelled with your name and the assignment reference.

PAST ASSIGNMENT (2019) - DO NOT USE FOR LIVE ASSESSMENT

Assignment Brief

A client has instructed you to carry out the remedial work in their house due to the walls and floors within the property becoming defective.

The client has requested advice on a modern and traditional floor screed system that could be laid to the ground floor oversite of the property. You are required to produce a proposal document for the client to help them decide what type of floor screed system would best suit the property.

Your proposal **must** include the following points;

- an explanation of the advantages and disadvantages of using each system
- a description of methods of installation and curing times
- a cost comparison between the two systems.

The wall surfaces have different defects that will require re-plastering using an appropriate plastering system. There is a timber stud partition and a solid masonry return that requires plastering internally and an external masonry pillar that requires plain rendering.

The internal work involves lining a timber stud partition with a standard wallboard, that also includes a raking angle cut of 30° to the top edge of the board, a ventilation outlet for air conditioning, a service box and a return formed with a lightweight backing plaster. Both surfaces are to be finished with a setting plaster and left ready for decoration.

The external pillar needs to be rendered using a two-coat traditional sand and cement render to form a plain face finish with a sharp external angle. The base of the wall requires a bell cast drip formed with beads and the external angle (arris) must be formed straight without the use of angle beads.

Refer to the specification and drawings in Figures 1-4 for dimensions. Appropriate guidelines should be used when setting out for the work.

On completion of the work you are required to self-evaluate your performance to include:

- what went well
- what didn't go so well
- what you would do differently in future.

Figure 1 Timber stud and blockwork background

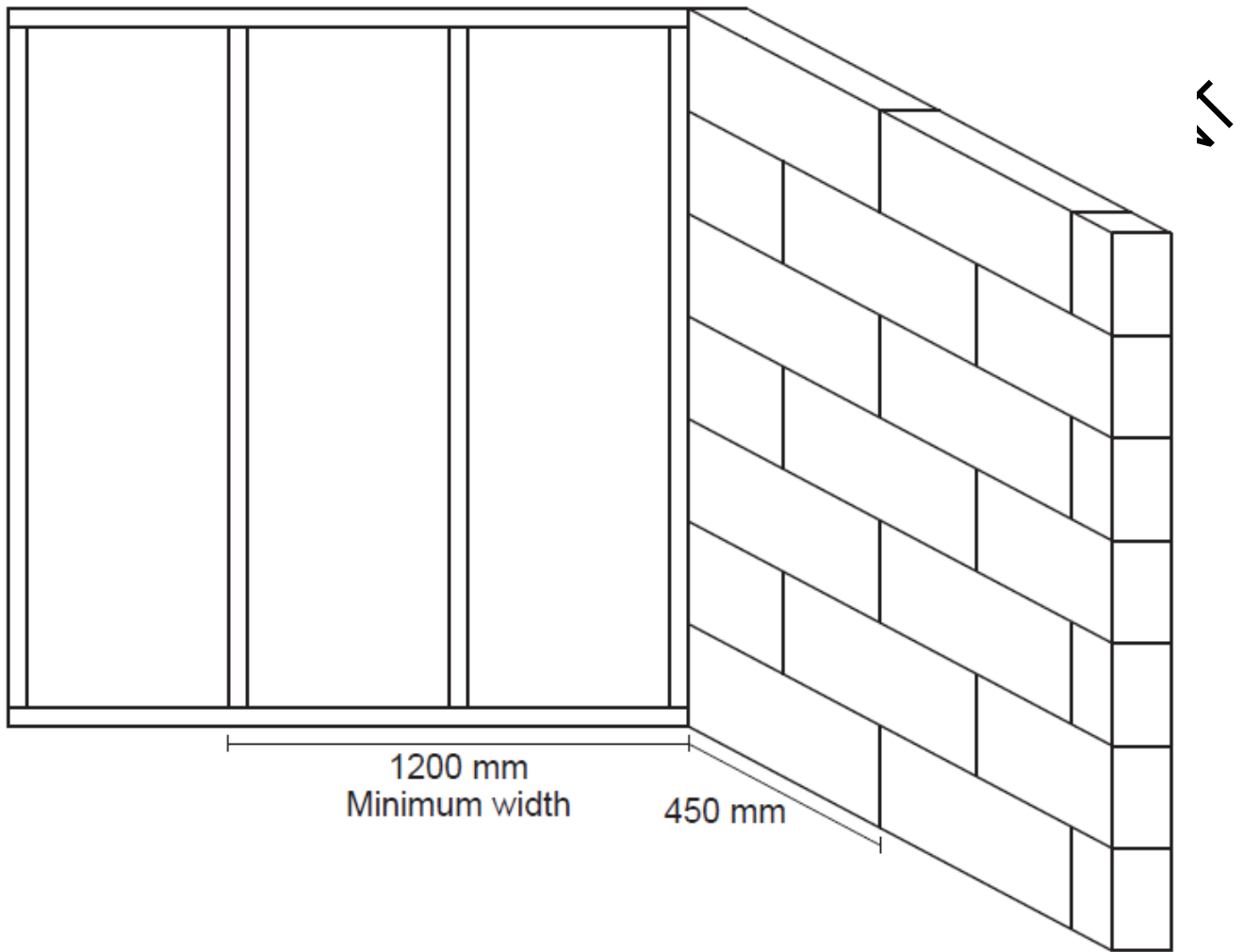

PAST ASSIGNMENT (20

Figure 2 Installation of plasterboard and plastering

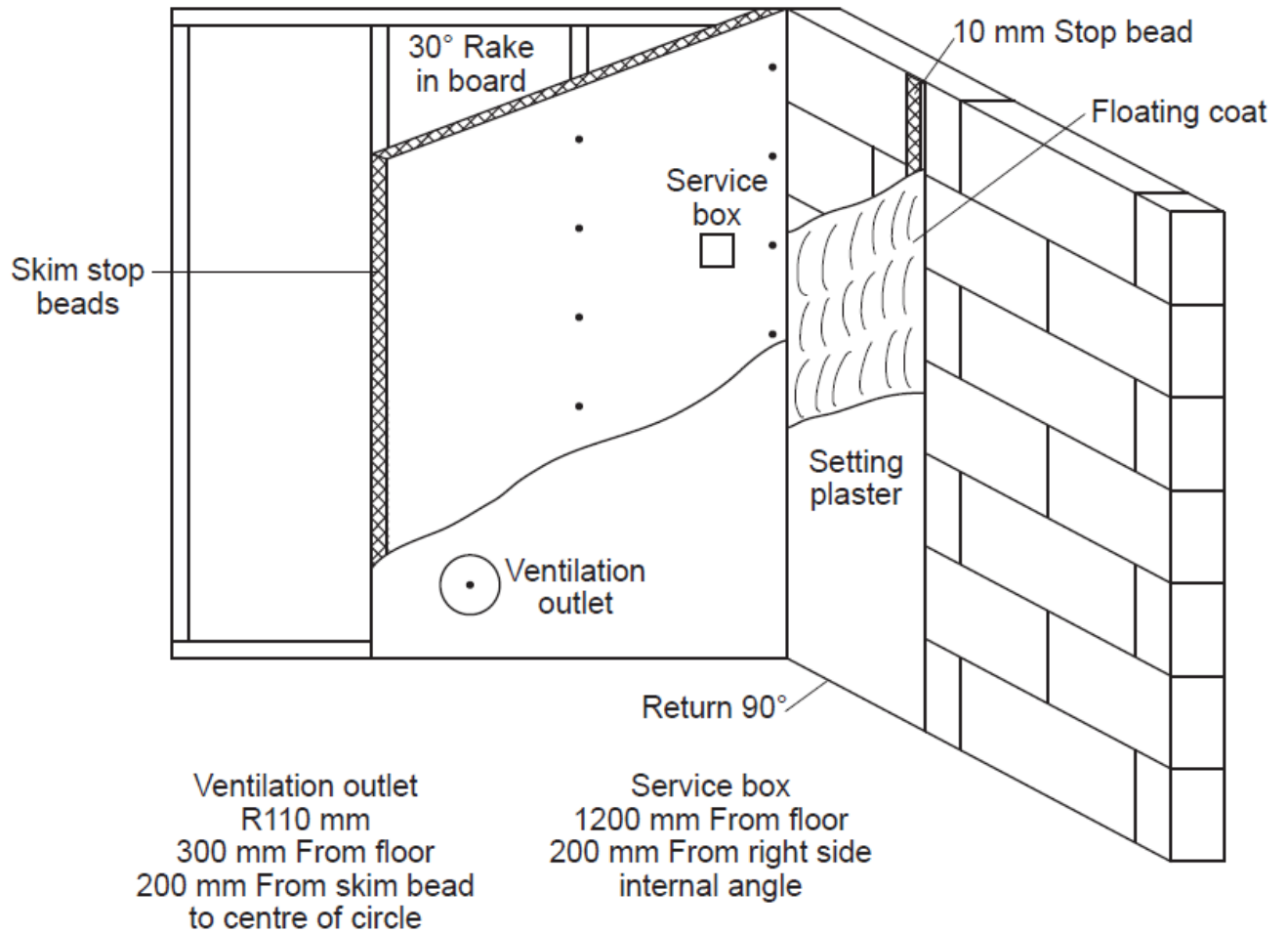

PAST ASSIGNMENT

Figure 3 Position of fixed bell beads

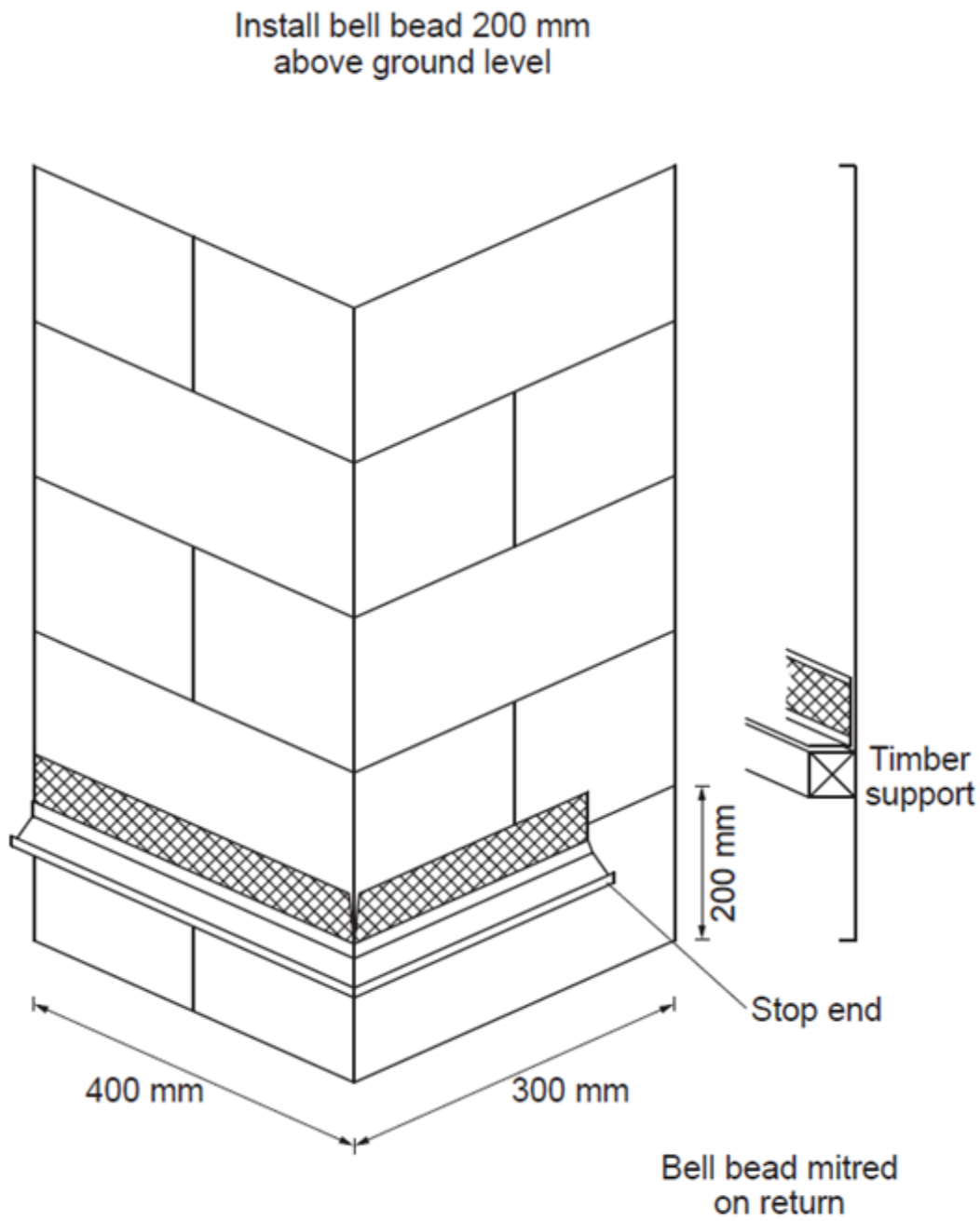

ASSMENT

PAST

Figure 4 Applied plain face two coat render to pillar

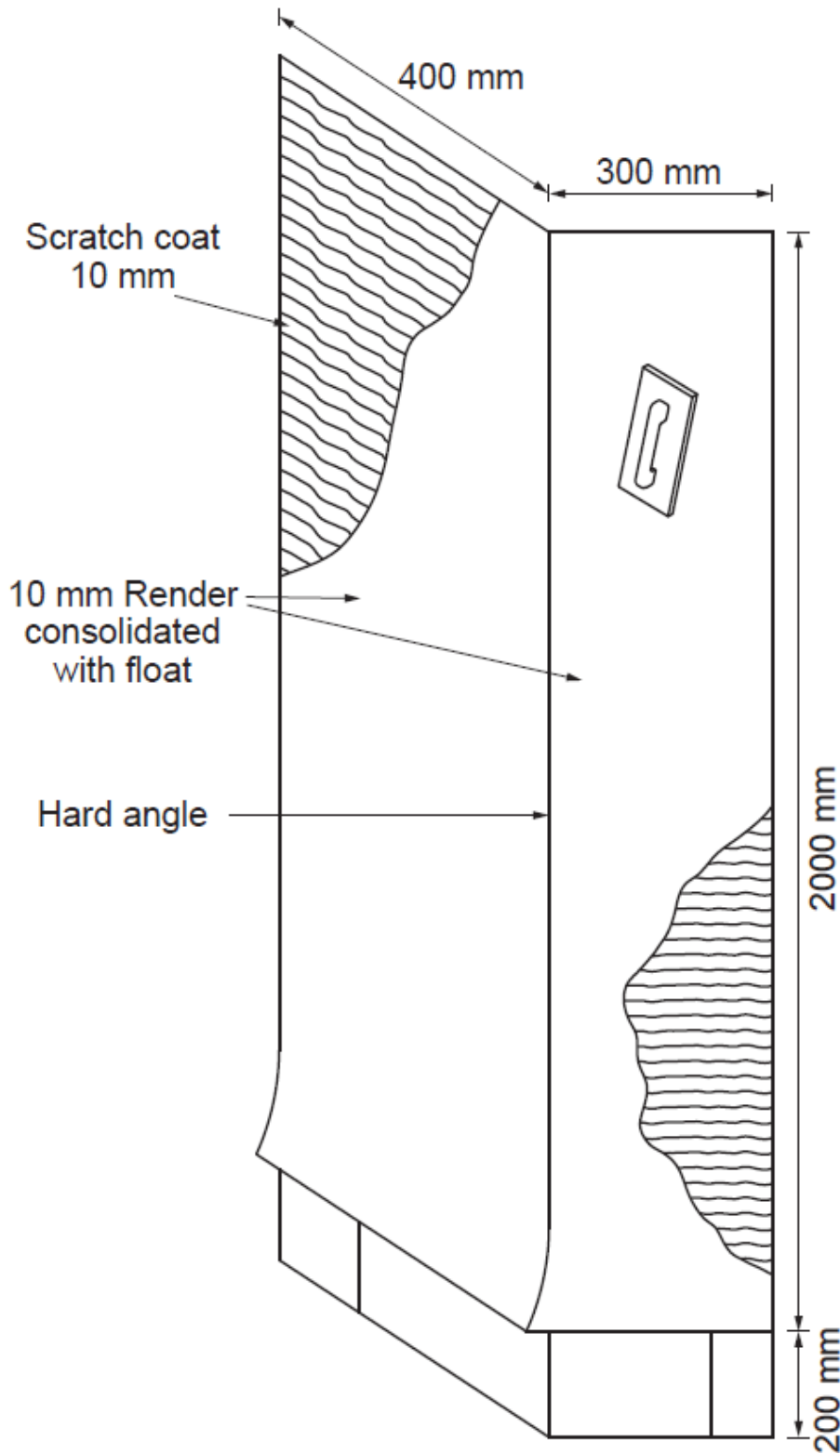

ASSESSMENT

PAST

Tasks

Task 1 Produce a proposal document

Conditions of assessment:

The task should be carried out working under supervision of the tutor and must be your own work. This **must** be completed prior to undertaking the practical tasks within the synoptic assignment.

What must be produced for marking and submitted for moderation (if applicable):

- a proposal document which must be hand written or typed on a minimum of 3 A4 sheet of paper referring to the bullet points above.

Task 2 Plan to carry out the works

Complete a resource list that identifies the tools, equipment and materials that would be required to carry out the remedial works and state your reasons for selecting the appropriate items.

Conditions of assessment:

The task should be carried out working alone under supervised conditions. This **must** be completed prior to undertaking the practical tasks within the synoptic assignment.

What must be produced for marking and submitted for moderation:

- resource list with reasons for your selections.

Task 3 Carry out the internal plastering

3a Install plasterboard surface and beads

3b Apply lightweight backing and setting coat plasters.

Conditions of assessment:

The task should be carried out working alone under supervised conditions. You must work safely at all times. If for any reason your assessor feels you are working in an unsafe manner, the assessment will be stopped with immediate effect.

What must be produced for marking and submitted for moderation:

- position of wallboard
- position of thin coat stop beads
- position of 10 mm stop bead
- devil floated backing coat
- finished setting plaster surface.

Additional evidence of your performance that must be captured for marking and submitted for moderation:

- your tutor's notes, recorded on a Practical Observation form, of your working practice describing in detail the quality, consistency and accuracy of the finished work.

- photographs **must** be taken by your assessor at the following stages and must show the overall appearance of the
 - fixed sheet of plasterboard with fixings and correct positioning of the thin coat beads to include cut out service boxes
 - floated background keyed, cut back at the position of the 10 mm stop bead.
 - trowelled finished surface of both sides of the wall.

Task 4 Carry out a plain face render finish to a pier

4a Fix bell beads and apply scratch coat

4b Apply render top coat and form plain face finish.

Conditions of assessment:

The task should be carried out working alone under supervised conditions. You must work safely at all times. If for any reason your assessor feels you are working in an unsafe manner, the assessment will be stopped with immediate effect.

What must be produced for marking and submitted for moderation:

- bell beads fixed level and to correct dimensions
- applied and keyed scratch coat
- consolidated render surface to include hard angle.

Additional evidence of your performance that must be captured for marking and submitted for moderation:

- your tutor's notes, recorded on a Practical Observation form, of your working practice describing in detail the quality, consistency and accuracy of the finished work
- photographs **must** be taken by your assessor at the following stages and must show the overall appearance of the
 - fixed bell beads in the correct position
 - applied scratch coat with key.

Task 5 Complete a self-evaluation.

Conditions of assessment:

The evaluation must be carried out independently under supervised conditions.

What you must produce for marking:

- Completed self-evaluation (approximately 300 words).

Task instructions for centres

Candidates must have access to a suitable range of resources to carry out the tasks and, where appropriate, to have the opportunity to choose materials demonstrating the ability to select from a range of appropriate materials.

Task specific guidance

Task 1

The centre must provide suitable IT equipment to carry out the research and complete the task whilst supervising the candidate. The proposal must be the candidates own work and must be completed on a word document. The candidates **must** complete this task prior to undertaking the practical tasks within the synoptic assignment. The **recommended** time for candidates to complete this task is **6 hours**, however this is **not** included in the total timings allowed to undertake the synoptic assignment.

Task 2

The candidates should be provided with suitable resources to complete the task. The candidates **must** complete this task prior to undertaking the practical tasks within the synoptic assignment. The recommended time for candidates to complete this task is **2 hours**, however this is **not** included in the total timings allowed to undertake the synoptic assignment.

Task 3

The centres need to provide a suitable timber partition with a solid brick or block wall to form a square return per learner with a minimum height of 2200 mm.

Material specification:

- wall boards 2400 mm x 1200 mm x 12.5 mm (SE)
- dry wall screws
- thin coat stop beads
- self-adhesive solum
- 10 mm stop bead
- lightweight backing plaster
- multi finish setting plaster.

Task 4

The centres need to provide a suitable pier wall per learner with a minimum height of 2200 mm.

Material specification:

- sand
- cement or lime
- additives
- 15 mm bell bead.

Suggested schedule for Task 3 and Task 4: (bring it all together in time due to drying times of the plaster and render)

Tasks 3 and 4 will run alongside each other

Day 1

- cut and fix bell beads and apply scratch coat (reversible)
- cut and fix wall board to timber stud
- cut and fix 10 mm stop bead to solid background
- float solid return.

Day 2

- apply plain render to both sides of pillar
- fix thin coat beads to plasterboard edge and cut out services
- apply setting plaster to both background
- Consolidate render and form sharp arris.

Task 5

The candidate's self-evaluation of performance across all tasks must be completed **no more than one week** after completion of the practical assessment. It is recommended that candidates leave adequate time to reflect on their performance of the tasks.

The candidate can either provide a typed or hand written evaluation. The candidate should have access to adequate resources to complete this task.

The recommended time for candidates to complete this task is 1 hour, however this is **not** included in the total timings allowed to undertake the synoptic assignment.

Guidance on photographs

It is expected that **6** photographs will be submitted per candidate. These photographs should be used to support the observation recorded upon the Practical Observation Sheet.

It is important that the file name for **each** photograph **must** include the candidate's name and a description eg J.Jones and the name of the task.

Task 3

The following photographs should be submitted for marking and moderation;

- Photograph 1 – the overall appearance of the fixed sheet of plasterboard with fixings and correct positioning of the thin coat beads to include cut out service boxes
- Photograph 2 – the overall appearance of the floated background keyed, cut back at the position of the 10 mm stop bead.
- Photograph 3 – the overall appearance of the trowelled finished surface of both sides of the wall.

Task 4

The following photographs should be submitted for marking and moderation;

- Photograph 1 – the overall appearance of the fixed bell beads in the correct position.
- Photograph 2 – the overall appearance of the applied scratch coat with key.
- Photograph 3 – the overall appearance of the finished render surface including hard angle.

Time

The following timings are recommended to support centre planning.

Total 12 hours

- Task 1** 6 hours, the time taken to complete this task is **not** included within the **twelve** hours
- Task 2** 2 hours, the time taken to complete this task is **not** included within the **twelve** hours
- Task 3** 7 hours
- Task 4** 5 hours
- Task 5** 1 hour the time taken to complete this task is **not** included within the **twelve** hours

PAST ASSIGNMENT (2019) - DO NOT USE FOR LIVE ASSESSMENT

Centre guidance

Guidance provided in this document supports the administration of this assignment. The following documents available on the City & Guilds website provide essential generic guidance for centres delivering Technical qualifications and **must** be referred to alongside this guidance:

- **Technical qualifications – marking**
- **Technical qualifications – moderation** (updated annually)
- **Technical qualifications – teaching, learning and assessment**

This synoptic assessment is designed to require the candidate to make use of their knowledge, understanding and skills they have built up over the course of their learning to tackle problems/tasks/challenges.

This approach to assessment emphasises to candidates the importance and applicability of the full range of their learning to practice in their industry area, and supports them in learning to take responsibility for transferring their knowledge, understanding and skills to the practical situation, fostering independence, autonomy and confidence.

Candidates are provided with an assignment brief. They then have to draw on their knowledge and skills and independently select the correct processes, skills, materials, and approaches to take to provide the evidence specified by the brief.

During the learning programme, it is expected that tutors will have taken the opportunity to set shorter, formative tasks that allow candidates to be supported to independently use the learning they have so far covered, drawing this together in a similar way, so they are familiar with the format, conditions and expectations of the synoptic assessment.

Candidates should be made aware during learning what the Assessment Objectives are and how they are implemented in marking the assignment, so they will understand the level of performance that will achieve them high marks.

Candidates should not be entered for the assessment until the end of the course of learning for the qualification so they are in a position to complete the assignment successfully.

Health and safety

Candidates should not be entered for assessment without being clear of the importance of working safely, and practice of doing so. The tutor must immediately stop an assessment if a candidate works unsafely. At the discretion of the tutor, depending on the severity of the incident, the candidate may be given a warning. If they continue to work unsafely however, their assessment must be ended and they must retake the assessment at a later date.

Compliance with timings

The timings provided are estimates to support centre planning. They refer to assessment time, not any additional setting up the centre needs to carry out to create the required to ensure an appropriate assessment environment.

It is the centre's responsibility to plan sufficient assessment sessions, under the appropriate conditions, within the assignment window, to allow candidates reasonable time to complete the assessment tasks.

Where candidates are required to plan their work they should have their plans confirmed for appropriateness in relation to the time allocated for each task.

Candidates should be allowed sufficient time to fully demonstrate the range of their skills, however this also needs to be reasonable and practicable. Candidates should be allowed to overrun their planned timings or professional service times (where they exist) in order for evidence of a range of their skills to be captured. If however, the time required exceeds reasonably set assessment periods, or the tolerance suggested for professional service times, the centre may stop the assessment and base the marking on the evidence up to that point, including the tutor's notes of how far over time the task has taken.

Observation evidence

Where the tutor is required to carry out observation of performance, detailed, descriptive notes must be recorded on the practical observation (PO) form provided. The centre has the flexibility to adapt the form, to suit local requirements (eg to use tablet, hand-written formats, or to ease local administration) as long as this does not change or restrict the type of evidence collected.

The number of candidates a tutor will be able to observe at one time will vary depending on:

- the complexity of evidence collection for the task
- local conditions eg layout of the assessment environment,
- amount of additional support available (eg to capture image/video evidence), staggered starts etc,
- whether there are any peak times where there is a lot of evidence to collect that will need additional support or any that are quieter.

It is advisable to trial the planned arrangements where possible during formative assessment, reviewing the quality of evidence captured and manageability. It is expected that for straight forward observations, (and unless otherwise specified) no more than eight candidates will be observed by a single tutor at one time, and the number will usually be fewer than this maximum. The key factor to consider is the logistics of collecting sufficient evidence.

As far as possible, candidates should not be distracted, or their performance affected by the process of observation and evidence collection.

Observation notes form part of the candidate's evidence and must describe **how well** the activity has been carried out, rather than stating the steps/ actions the candidate has taken. The notes must be very descriptive and focus on the **quality** of the performance in such a way that comparisons between performances can be made. They must provide sufficient, appropriate evidence that can be used by the marker (and moderator) to mark the performance using the marking grid.

Identifying what **it is** about the performances that is **different** between candidates can clarify the qualities that are important to record. Each candidate is likely to carry out the same steps, so a checklist of this information would not help differentiate between them. However, qualitative comments on **how well** they do it, and quantitative records of accuracy and tolerances would.

The tutor should refer to the marking grid to ensure appropriate aspects of performance are recorded. These notes will be used for marking and moderation purposes and so must be **detailed, accurate and differentiating**.

Tutors should ensure that any required additional supporting evidence including eg photographs or video can be easily matched to the correct candidate, are clear, well-lit and showing the **areas of particular interest** in **sufficient detail** and **clarity** for assessment (ie taken at appropriate points in production, showing accuracy of measurements where appropriate).

If candidates are required to work as a team, each candidate's contribution must be noted separately. The tutor may intervene if any individual candidate's contribution is unclear or to ensure fair access (see below).

The **Technical qualifications guides on marking and moderation** are essential guidance documents and are available on the City & Guilds website. These provide further information on preparing for assessment, evidence gathering, standardisation, marking and moderation, and must be referred to when planning and carrying out assessment.

Minimum evidence requirements for marking and moderation

The sections in the assignment:

- **What you must produce for marking**, and
- **Additional evidence of your performance that must be captured for marking**

list the minimum requirements of evidence to be submitted for marking and the moderation sample.

Evidence produced during assessment above and beyond this may be submitted, as long as it provides useful information for marking and moderation and has been produced under appropriate conditions.

While technological methods which support the capturing or creating of evidence can be helpful, eg pinboard style websites for creating mood boards, the final evidence must be converted to a suitable format for marking and moderation which cannot be lost/ deleted or amended after the end of the assessment period (eg screen prints, pdf files). Considerations around tracking authenticity and potential loss of material hosted on such platforms during assessment is the centre's responsibility.

Where candidates have carried out some work as a group, the contribution of each candidate must be clear. It is not appropriate to submit identical information for each candidate without some way for the marker and moderator to mark the candidates individually.

Note: Combining candidates' individual pieces of evidence into single files or zip files may make evidence management during internal marking more efficient and will greatly simplify the uploading of the moderation sample.

Where the minimum requirements have **not been submitted** for the moderation sample by the final moderation deadline, or the **quality of evidence is insufficient** to make a judgement, the moderation, and therefore any subsequent adjustment, will be based on the evidence that *has been* submitted. **Where this is insufficient to provide a mark on moderation, a mark of zero may be given.**

Preparation of candidates

Candidates should be aware of which aspects of their performance (across the AOs) will give them good marks in assessment. This is best carried out through routinely pointing out good or poor performance during the learning period, and through formative assessment.

During the learning programme, direct tutor instruction in how to tackle practical tasks through modelling, support, guidance and feedback are critical. However gradual removal of this support is necessary in preparation for summative assessment. This, supported approach is **not** valid for summative assessment.

The purpose of summative assessment is to confirm the standard the candidate has reached as a result of participating in the learning process. Candidates should be encouraged to do the best they can and be made aware of the difference between these summative assessments and any formative assessments they have been subject to. Candidates may not have access to the full marking grids, as these may be misinterpreted

as pass, merit distinction descriptors. Refer to the **Technical qualifications – teaching, learning and assessment** centre guidance document, available on the City & Guilds website for further information on preparing candidates for Technical qualification assessment.

Guidance on assessment conditions

The assessment conditions that are in place for this synoptic assignment are to:

- ensure the rigour of the assessment process
- provide fairness for candidates
- give confidence in the outcome.

They can be thought of as the rules that ensure that all candidates who take an assessment are being treated fairly, equally and in a manner that ensures their result reflects their true ability.

The conditions outlined below relate to this summative synoptic assignment. These do not affect any formative assessment work that takes place, although it is advised that candidates are prepared for the conditions they will need to work under during summative assessment.

The evidence for the tasks that make up this synoptic assignment must be completed under the specified conditions. This is to ensure authenticity and prevent malpractice as well as to assess and record candidate performance for assessment in the practical tasks. Any aspect that may be undertaken in unsupervised conditions is specified. It is the centre's responsibility to ensure that local administration and oversight gives the tutor sufficient confidence to be able to confirm the authenticity of the candidate's work.

Security and authentication of candidate work

Candidate evidence must be kept secure to prevent unsupervised access by the candidate or others. Where evidence is produced over a number of sessions, the tutor must ensure learners and others cannot access the evidence without supervision. This might include storing written work or artefacts in locked cupboards and collecting memory sticks of evidence produced electronically at the end of each session.

Candidates are required to sign declarations of authenticity, as is the tutor. The relevant form is included in this assignment pack and must be signed after the production of all evidence.

Where the candidate or tutor is unable to, or does not confirm authenticity through signing the declaration form, the work will not be accepted at moderation and a mark of zero will be given. If any question of authenticity arises eg at moderation, the centre may be contacted for justification of authentication.

Accessibility and fairness

Where a candidate has special requirements, tutors should refer to the *Access arrangements and reasonable adjustments* section of the City & Guilds website.

Tutors can support access where necessary by providing clarification to **any** candidate on the requirements or timings of any aspect of this synoptic assignment. Tutors should **not** provide more guidance than the candidate needs as this may impact on the candidate's grade, see the guidance and feedback section below.

All candidates must be provided with an environment, time frame and resources that allows them reasonable access to the full range of marks available.

Where candidates have worked in groups to complete one or more tasks for this synoptic assessment, the tutor must ensure that no candidate is disadvantaged as a result of the performance of any other team member. If a team member is distracting or preventing another team member from fully demonstrating their skills or knowledge, the tutor must intervene.

Guidance and feedback

To support centre file management, tutors may specify a suitable file format and referencing format for evidence (unless otherwise specified eg if file naming is an assessment point for the assignment). Guidance must only support access to the assignment and must not provide feedback for improvement. The level and frequency of clarification & guidance must be

- recorded fully on the candidate record form (CRF),
- taken into account along with the candidate's final evidence during marking
- made available for moderation.

Tutors **must not** provide feedback on the quality of the performance or how the quality of evidence can be improved. This would be classed as malpractice.

Tutors **should** however provide general reminders to candidates throughout the assessment period to check their work thoroughly before submitting it, and to be sure that they are happy with their final evidence as it may not be worked on further after submission.

Candidates can rework any evidence that has been produced for this synoptic assignment during the time allowed. However, this must be as a result of their own review and identification of weaknesses and not as a result of tutor feedback. Once the evidence has been submitted for assessment, no further amendments to evidence can be made.

Tutors **should** check and be aware of the candidates' plans and designs to ensure management of time and resources is appropriate, and so any allowed intervention can take place at an appropriate time.

Tutors **should** ensure that candidates' plans for completion of the tasks distribute the time available appropriately and may guide candidates on where they should be up to at any point in a general way. Any excessive time taken for any task should be recorded and should be taken into account during marking if appropriate.

It is up to the marker to decide if the guidance the candidate has required suggests they are lacking in any AO, the severity of the issue, and how to award marks on the basis of this full range of evidence. The marker must record where and how guidance has had an impact on the marks given, so this is available should queries arise at moderation or appeal.

What is and is not, an appropriate level of guidance

A tutor **should intervene with caution** if a candidate has taken a course of action that will result in them not being able to submit the full range of evidence for assessment. However, this should **only** take place once the tutor has prompted the candidate to check that they have covered all the requirements. Where the tutor has to be explicit as to what the issue is, this is likely to demonstrate a lack of understanding on the part of the candidate rather than a simple error, and full details should be recorded on the CRF.

- The tutor **should not** provide guidance if the candidate is thought to be able to correct the issue without it, and a prompt would suffice. In other words, only the minimum support the candidate actually needs should be given, since the more tutor

guidance provided, the less of the candidate's own performance is being demonstrated and therefore the larger the impact on the marks awarded.

- A tutor **must not** provide guidance that the candidate's work is not at the required standard or how to improve their work. In this way, candidates are given the chance to identify and correct any errors on their own, providing valid evidence of knowledge and skills that will be credited during marking.
- The tutor **must not** produce any templates, pro-formas, work logs etc unless instructed to in the assignment guidance. Where instructed to do so, these materials must be produced as specified and contain no additional guidance. Templates provided as part of the assignment should be used as provided, and not adapted.

All specific prompts and details of the nature of any further guidance must be recorded on the relevant form and reviewed during marking and moderation.

Guidance on marking

Please refer to the **Technical qualifications – marking, and - moderation** centre guidance documents for further information on gathering evidence suitable for marking and moderation, and on using the marking grid and forms.

The candidate record form (CRF) is used to record:

- Details of any guidance or the level of prompting the candidate has received during the assessment period
- Rough notes bringing together relevant evidence from across tasks during marking.
- Summary justifications when holistically coming to an overall judgement of the mark.

The practical observation form (PO) is used to record:

- Descriptive information and evidence of candidate performance during an observation. Although descriptions of the quality of performance should support decisions against the AOs, the notes should follow the flow of the observation, rather than attempting to assign evidence against the AOs at this point.

Marking grid

For any category, 0 marks may be awarded where there is no evidence of worthy achievement.

| % | Assessment Objective | Band 1 descriptor Poor to limited | Band 2 descriptor Fair to good | Band 3 descriptor Strong to excellent |
|---|---|--|--|---|
| 10 | AO1 Recall of knowledge relating to the qualification LOs <ul style="list-style-type: none"> Does the candidate seem to have the full breadth and depth of taught knowledge across the qualification to hand? How accurate is their knowledge? Are there any gaps or misunderstandings evident? How confident and secure does their knowledge seem? | <p style="text-align: center;">(1-2 marks)</p> <p>Recall shows some weaknesses in breadth and/or accuracy. Hesitant, gaps, inaccuracy.</p> | <p style="text-align: center;">(3-4 marks)</p> <p>Recall is generally accurate and shows reasonable breadth. Inaccuracies and misunderstandings are infrequent and usually minor. Sound, minimal gaps.</p> | <p style="text-align: center;">(5-6 marks)</p> <p>Consistently strong evidence of accurate and confident recall from the breadth of knowledge. Accurate, confident, complete, fluent.</p> |
| <p>Examples of types of knowledge expected: interpreting information sources in relation to planning and carrying out the tasks i.e specifications/drawings/manufacturers information.</p> | | | | |
| | | <p>The candidate has demonstrated limited recall of knowledge, but it has been limited and/or showing hesitancy on all aspects and needs prompting when interpreting technical information relating to the task/s.</p> | <p>The candidate has demonstrated a good recall of knowledge but is hesitant on minor aspects when interpreting technical information relating to the task/s.</p> | <p>The candidate has demonstrated in-depth and detailed knowledge, showing a higher degree of confidence and understanding when interpreting technical information relating to the task/s.</p> |

MENT

| | | | | |
|----|--|---|---|---|
| 20 | AO2 Understanding of concepts, theories and processes relating to the LOs <ul style="list-style-type: none"> Does the candidate make connections and show causal links and explain why? How well are theories and concepts applied to new situations/ the assignment? How well are exemplars chosen – how well do they illustrate the concept? | (1-4 marks) Some evidence of being able to give explanations of concepts and theories. Explanations appear to be recalled, simplistic or incomplete. Misunderstanding, illogical connections, guessing. | (5-8 marks) Explanations are logical. Showing comprehension and generally free from misunderstanding, but may lack depth or connections are incompletely explored. Logical, slightly disjointed, plausible. | (9-12 marks) Consistently strong evidence of clear causal links in explanations generated by the candidate. Candidate uses concepts and theories confidently in explaining decisions taken and application to new situations. Logical reasoning, thoughtful decisions, causal links, justified. |
| | | Examples of understanding expected: select appropriate materials, tools, equipment and PPE to set out and undertake the task; follow the correct sequence of work. | | |
| | | Shows a limited understanding of plastering methods, techniques and resources. Drawings/specifications not clearly interpreted and understood. To access higher marks Hesitant when identifying and selects majority of the appropriate materials, tools and equipment to undertake the task/s. | Shows a good understanding of plastering methods, techniques and resources. Drawings/specifications generally interpreted and understood. To access higher marks Identifies and selects the majority of the appropriate materials, tools and equipment to undertake the task/s. | Shows consistent, confident and accurate understanding of plastering methods, techniques and resources. Drawings/specifications interpreted and clearly understood. To access higher marks Confidently identifies and selects appropriate materials, tools and equipment to undertake the task/s. |

PAST ASSIGNMENT

| | | | | |
|----|---|--|---|---|
| 40 | AO3 Application of practical/ technical skills <ul style="list-style-type: none"> How practiced/fluid does hand eye coordination and dexterity seem? How confidently does the candidate use the breadth of practical skills open to them? How accurately/successfully has the candidate been able to use skills/achieve practical outcomes? | <p>(1-8 marks)</p> <p>Some evidence of familiarity with practical skills. Some awkwardness in implementation, may show frustration out of inability rather than lack of care.</p> <p>Unable to adapt, frustrated, flaws, out of tolerance, imperfect, clumsy.</p> | <p>(9-16 marks)</p> <p>Generally successful application of skills, although areas of complexity may present a challenge. Skills are not yet second nature.</p> <p>Somewhat successful, some inconsistencies, fairly adept/capable.</p> | <p>(17-24 marks)</p> <p>Consistently high levels of skill and/or dexterity, showing ability to successfully make adjustments to practice; able to deal successfully with complexity.</p> <p>Dextrous, fluid, comes naturally, skilled, practiced.</p> |
| | | <p>Examples of skills expected: practical techniques to include: setting out, measuring, cutting, scribing, positioning and installing, levelling, plumbing, preparing, gauging and mixing, applying, ruling, fixing, squaring, rasping, keying and cutting back. Producing different surface finishes. Adherences to tolerances.</p> | | |
| | | <p>Work not completed within the given timescale. Some elements of the task not attempted. Practical skills are demonstrated to a poor standard. Majority of measurements are inaccurate. No tolerances met.</p> <p>To access higher marks Demonstrates some professional techniques when performing set tasks.</p> | <p>All work planned, attempted and completed within given timescale. Practical skills are demonstrated to an acceptable standard. Majority of measurements are mostly accurate. Some tolerances met.</p> <p>To access higher marks Demonstrates good professional techniques a majority of the time when performing set tasks.</p> | <p>All work planned, attempted and completed within given timescale. Practical skills are demonstrated to a high standard. All measurements are accurate. All tolerances met.</p> <p>To access higher marks Fully demonstrates consistent professional techniques when performing set tasks.</p> |

| | | | | |
|----|---|---|---|--|
| 20 | AO4 Bringing it all together - coherence of the whole subject <ul style="list-style-type: none"> Does the candidate draw from the breadth of their knowledge and skills? Does the candidate remember to reflect on theory when solving practical problems? How well can the candidate work out solutions to new contexts/problems on their own? | (1-4 marks) Some evidence of consideration of theory when attempting tasks. Tends to attend to single aspects at a time without considering implication of contextual information. Some random trial and error, new situations are challenging, expects guidance, narrow. May need prompting. | (5-8 marks) Shows good application of theory to practice and new context, some inconsistencies. Remembers to apply theory, somewhat successful at achieving fitness for purpose. Some consolidation of theory and practice. | (9-12 marks) Strong evidence of thorough consideration of the context and use of theory and skills to achieve fitness for purpose. Purposeful experimentation, plausible ideas, guided by theory and experience, fit for purpose, integrated, uses whole toolkit of theory and skills. |
| | | Examples of bringing it all together: interpreted and demonstrated knowledge, understanding and skill to carry out the tasks, planned activities in a logical and timely manner, materials and application techniques used appropriately and correctly, safe and clean working practices demonstrated throughout. Self-evaluation of performance across all tasks. | | |

PAST ASSIGNMENT (2019) - DO NOT

ASSIGNMENT

| | | | | |
|----|--|---|--|---|
| | | <p>There is limited evidence of the candidate using their knowledge, understanding and skills to complete the tasks.</p> <p>Tasks are not planned, prepared or completed to the specification.</p> <p>Choices and decisions have been poorly informed, showing little consideration before being implemented. Demonstrated basic evaluation skills.</p> <p>To access higher marks Some decisions are indecisive when planning and finishing the activities within the task/s.</p> | <p>The candidate brings together their knowledge, understanding and skills well in order to complete the tasks.</p> <p>Most tasks are planned, prepared and completed to the specification, but may have some errors.</p> <p>Choices and decisions have been inconsistently informed, considered and implemented. Demonstrated adequate evaluation skills.</p> <p>To access higher marks Majority of decisions are decisive when planning and finishing the activities within the task/s.</p> | <p>The candidate has made excellent use of their knowledge, understanding and skills across the tasks.</p> <p>Tasks are methodically planned, prepared and completed to the specification.</p> <p>Choices and decisions have been well informed, considered and implemented. Demonstrated comprehensive evaluation skills.</p> <p>To access higher marks Made decisive decisions when planning and finishing the activities within the task/s.</p> |
| 10 | <p>AO5 Attending to detail/ perfecting</p> <ul style="list-style-type: none"> Does the candidate routinely check on quality, finish, etc. and attend to imperfections/ omissions How much is accuracy a result of persistent care and attention (eg | <p>(1-2 marks)</p> <p>Easily distracted or lack of checking. Insufficiently concerned by poor result; little attempt to improve. Gives up too early; focus may be on completion rather than quality of outcome.</p> <p>Careless, imprecise, flawed, uncaring, unfocussed, unobservant, unmotivated.</p> | <p>(3-4 marks)</p> <p>Aims for satisfactory result but may not persist beyond this. Uses feedback methods but perhaps not fully or consistently.</p> <p>Variable/intermittent attention, reasonably conscientious, some imperfections, unremarkable.</p> | <p>(5-6 marks)</p> <p>Alert, focussed on task. Attentive and persistently pursuing excellence. Using feedback to identify problems for correction.</p> <p>Noticing, checking, persistent, perfecting, refining, accurate, focus on quality, precision, refinement, faultless, meticulous.</p> |

| | | | |
|---|---|---|---|
| <p>measure twice, cut once)?</p> <ul style="list-style-type: none"> • Would you describe the candidate as a perfectionist and wholly engaged in the subject? | <p>Examples of attending to detail: Considerations for following trades. Wall surface area inline, even, uniform and defect free. Angles, reveals and soffits are square and marginable and inline. Beads: fixed, plumb, level, inline and intersect with no steps. Services, ceiling lines, wall lines, internal and external angles, skirting lines are clean. Beads left clean. Correct waste disposal.</p> | | |
| | <p>There is limited attention to detail/appearance. Rarely checks that work is accurate, clean and defect free. Work produced to a poor standard. Poor housekeeping. Poor consideration for other trades.</p> | <p>There is good attention to detail/appearance. Inconsistently checks that work is accurate, clean and defect free. Work produced to an adequate standard. Good housekeeping. Some consideration for other trades.</p> | <p>There is excellent attention to detail/appearance. Consistently and carefully double checks that work is accurate, clean and defect free. Work produced to a high standard. Excellent housekeeping with minimal waste. Excellent consideration for other trades.</p> |

PAST ASSIGNMENT (2019) - DO NOT USE