

# **Level 3 Advanced Technical Diploma in Plastering (Solid) (450) (7908-30)**

**Version 1.1**

## **Practice Tasks**

# Introduction

General information about structure of the practice tasks

Learner section

- Practice tasks guidance
- Completion of tasks
- Tasks

Assessor section

- Assessor guidance
- Guidance on tasks
- Knowledge question answer keys
- Appendix
- Declaration of Authenticity
- Feedback form

## Practice Tasks 7908-30

### General guidance

This is a formative assessment that you will complete. You will be observed and feedback will be given. You will be marked on the quality and accuracy of your practical performance and any written work you produce. It is therefore important that you carry your work out to the highest standard you can. You should show how well you know and understand the subject and how you are able to use your knowledge and skills together to complete the tasks.

### Health and Safety

You must always work safely, in particular while you are carrying out the practical tasks.

You must always follow any relevant Health and Safety regulations and codes of practice.

If your tutor sees you working in a way that is unsafe for yourself or others, they will ask you to stop immediately, and tell you why. Your tutor/assessor will not be able to reassess you until they are sure you are ready to work safely.

### Presentation of work

Presentation of work must be neat and appropriate to the task.

You should make sure that each piece of work is clearly labelled with your name and the task title.

Any electronic files must be given a clear file name that allows your tutor to identify it as your work.

## Tasks

You will be required to read the work scenario and use the candidate instructions for each practice task to produce the end product. You will be required to answer three multiple choice questions related to the tasks.

Your completed piece of work will be marked against the standards set out in the candidate instructions table within each practice task. Your tutor/Assessor will mark the multiple choice questions and provide you with feedback.

Your tutor/assessor will provide constructive feedback, highlighting areas of both good practice and areas requiring development.

Your performance will be observed throughout the task, and any help or guidance provided by your tutor/assessor or peers will be taken into consideration on the marking of your completed work.

# Tasks

## Task 1 Construct an in-situ running mould

<b>Candidate name</b>	
<b>Date</b>	

**Work scenario:** You have been asked to produce a zinc profile from a template and construct an in-situ running mould.

**Assessment method:** This practice task requires you to show case both your practical and knowledge skills when accurately producing a zinc template from a given drawing, and producing an in-situ running mould.

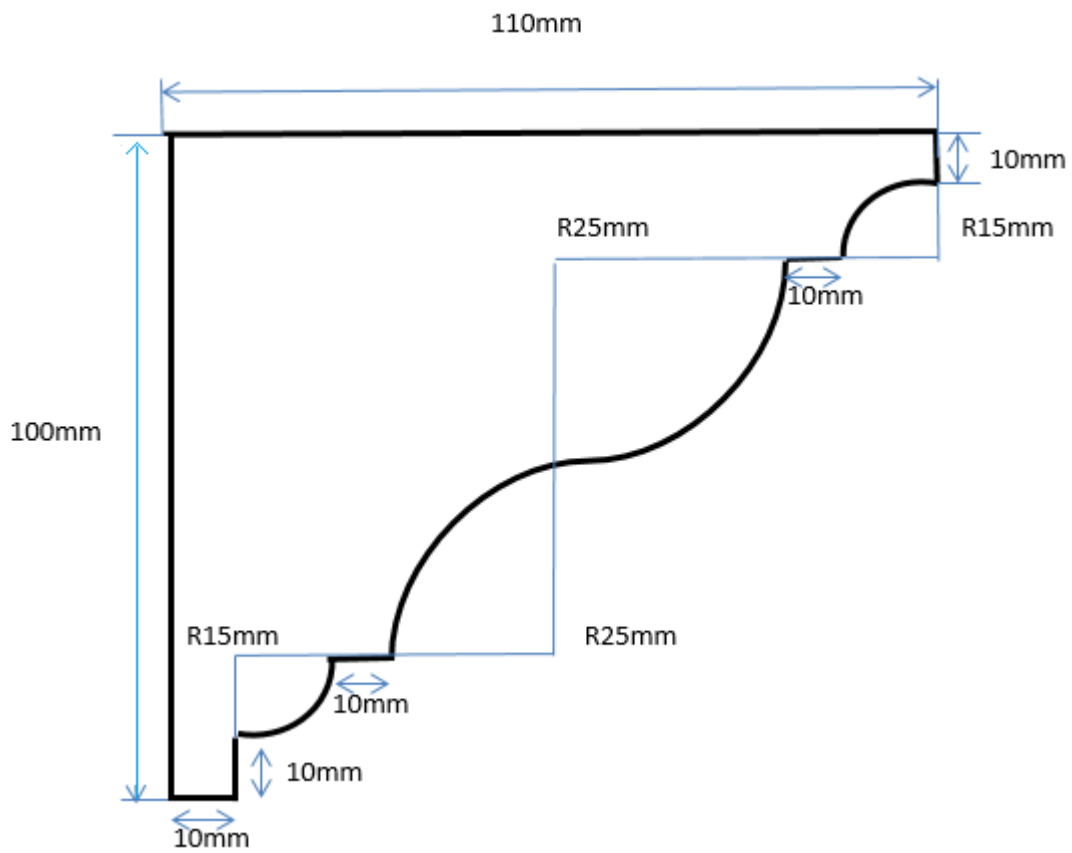
### Scope of content

#### You will be required to:

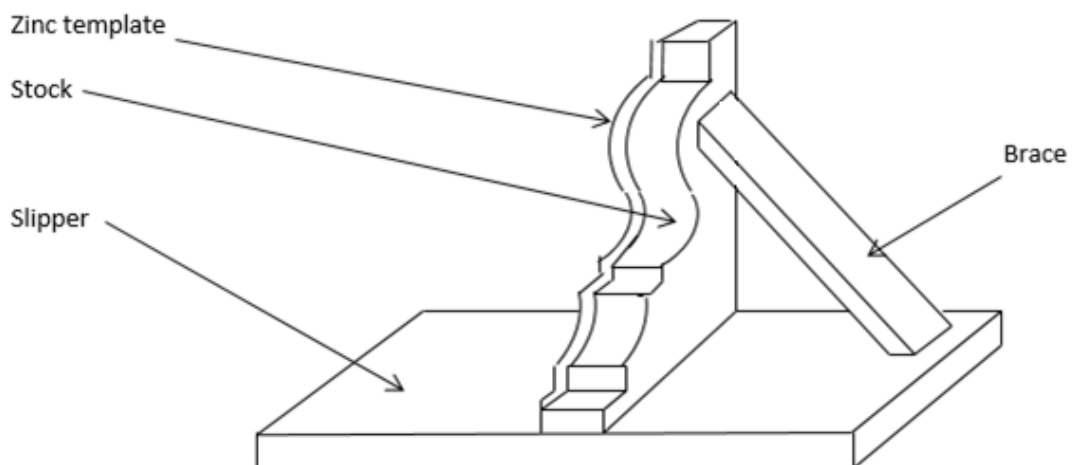
- Produce a zinc profile from a drawing template
- Construct an in-situ running mould

No	Candidate instructions	Achieved	
		Yes	No
1	Select the correct tools, materials and equipment.		
2	Transfer drawing to the zinc profile (Figure 1)		
3	Cut and file accurately from the given drawing template (Figure 1)		
4	Construct an in-situ running mould (Figure 2)		
5	Construct a false profile (Figure 3)		
6	Work safely at all times		
7	Housekeeping; <ul style="list-style-type: none"><li>• Leave work area clean and tidy</li><li>• Clean and store away materials correctly (if applicable)</li><li>• Dispose of waste correctly (if applicable).</li></ul>		

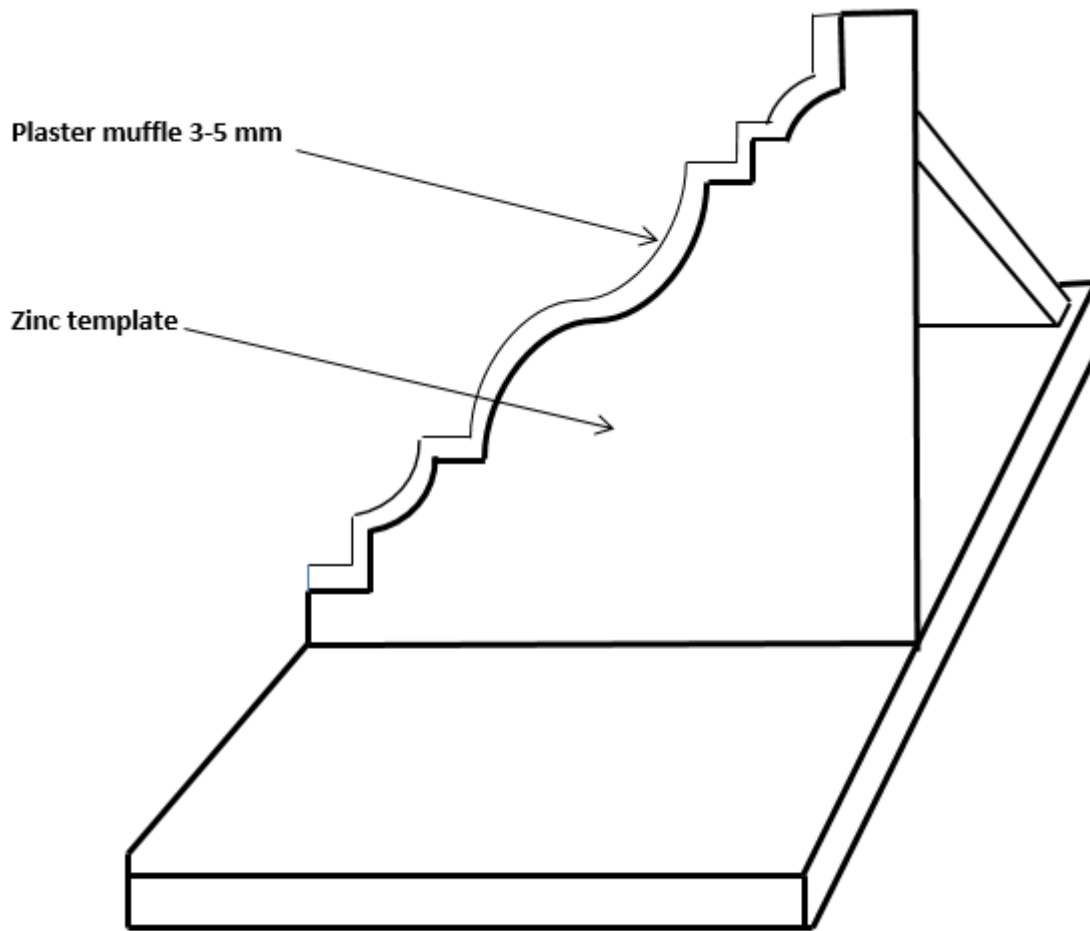
**Figure 1:** Drawing template



**Figure 2:** In-situ running mould

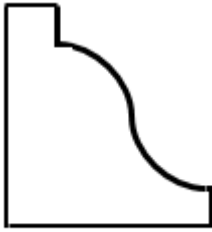


**Figure 3:** False profile



## Knowledge questions

1) What name is given to the profile in the image shown below?



- a) Cyma reversa.
  - b) Cyma recta.
  - c) Scotia.
  - d) Ovolo.
- 2) What is the purpose of a muffle?
- a) To form a shaped core.
  - b) To increase setting time.
  - c) To reduce setting time.
  - d) To improve appearance.
- 3) What type of moulding has a drip member?
- a) Internal cornice.
  - b) External corbel.
  - c) Internal dado.
  - d) External cornice.



## Feedback and action planning form

<b>Candidate name:</b>	
<b>Date:</b>	
<b>Task title:</b>	
<b>Candidate feedback</b>	
<b>Assessor feedback</b>	
<b>Action plan</b>	

## Task 2      Fix bracketing and run an in-situ cornice

<b>Candidate name</b>	
<b>Date</b>	

**Works Scenario:** Your company has asked you to go to site and run an in-situ cornice mould to match existing. You will need to fix bracketing to reduce the weight of the cornice and run using traditional lime mortars.

**Assessment method:** This practice task requires you to show case both your practical and knowledge skills when setting out and fixing timber brackets and laths, running a core using traditional lime mortars and running the finish coat using gauged lime putty to an in-situ curved cornice.

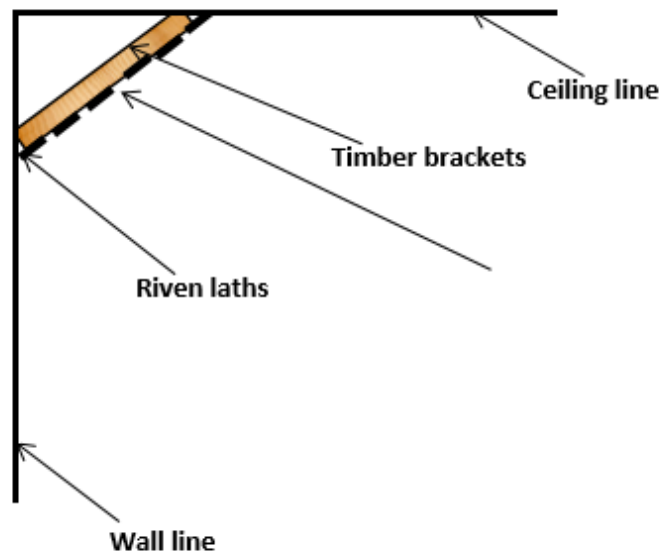
### Scope of content

#### You will be required to:

- Fix timber bracketing and laths
- Apply a pricking up coat
- Form a core
- Apply and run off finishing coat.

No	Candidate instructions	Achieved	
		Yes	No
1	Select the correct tools, materials and equipment		
2	Mark out the depth and projection of the cornice, ensuring the top and bottom members are square to the ceiling and wall. Fix timber brackets to 400 mm centres (Figure 1)		
3	Fix timber laths with a maximum 5 mm spacing (Figure 1)		
4	Fix running rules in position		
5	Apply a pricking up coat with a uniform key (Figure 2)		
6	Produce a core (Figure 2)		
7	Apply and run off the finishing coat with sharp members free from any blemishes or misses (Figure 2)		
8	Work safely at all times		
9	Housekeeping; <ul style="list-style-type: none"> <li>• Leave work area clean and tidy</li> <li>• Clean and store away materials correctly (if applicable)</li> <li>• Dispose of waste correctly (if applicable).</li> </ul>		

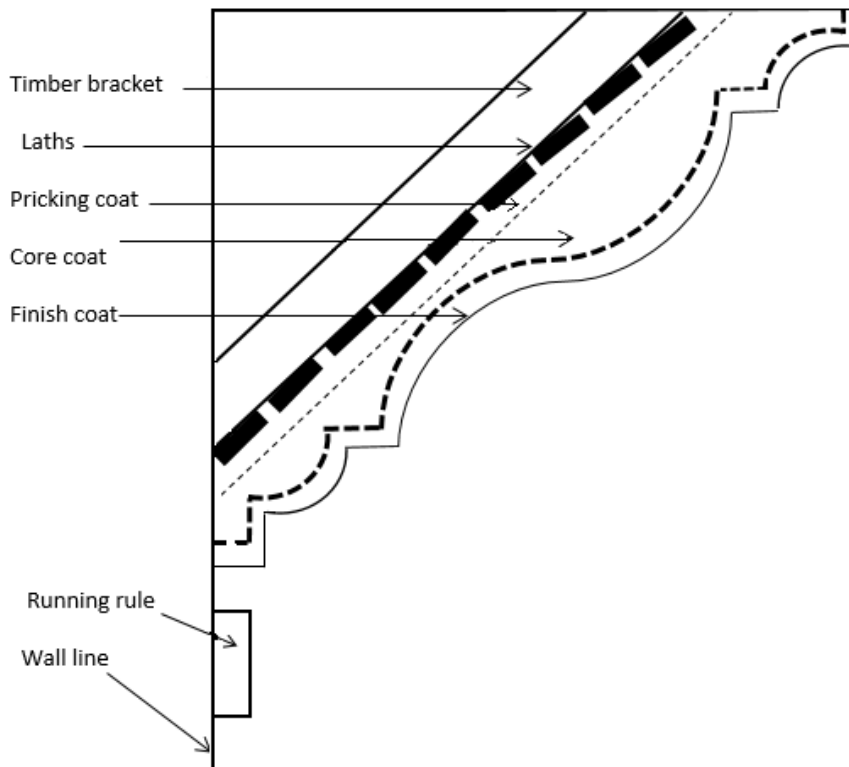
**Figure 1:** Timber bracketing



**Specifications for Figure 1:**

- Cornice depth 100mm
- Cornice projection 110mm
- Brackets fixed to maximum 400mm centres
- Laths fixed to the recommended 5mm spacing.

**Figure 2:** In-situ cornice



## Knowledge questions

- 1) What is the purpose of bracketing?
  - a) To reduce the set of the mould.
  - b) To increase the set of the mould.
  - c) To reduce the weight of the mould.
  - d) To increase the weight of the mould.
  
- 2) What is the **recommended** spacing between riven laths?
  - a) 5 mm
  - b) 10 mm
  - c) 15 mm
  - d) 20 mm
  
- 3) What name is given to a moulding section that is a quarter of a circle?
  - a) Scotia.
  - b) Ovolo.
  - c) Flute.
  - d) Corona.

## Feedback and action planning form

<b>Candidate name:</b>	
<b>Date:</b>	
<b>Task title:</b>	
<b>Candidate feedback</b>	
<b>Assessor feedback</b>	
<b>Action plan</b>	

### Task 3 Run a cornice and fix to external mitres

<b>Candidate name</b>	
<b>Date</b>	

**Work scenario:** You have been asked to run a short piece of cornice on a bench with a backboard. Cut two external mitres from the run and fix to the prepared in-situ cornice.

**Assessment method:** This practice task requires you to show case both your practical and knowledge skills when setting up and running a cornice, measuring cutting and fixing to two external mitres and stopping in mitres with all members sharp and in line.

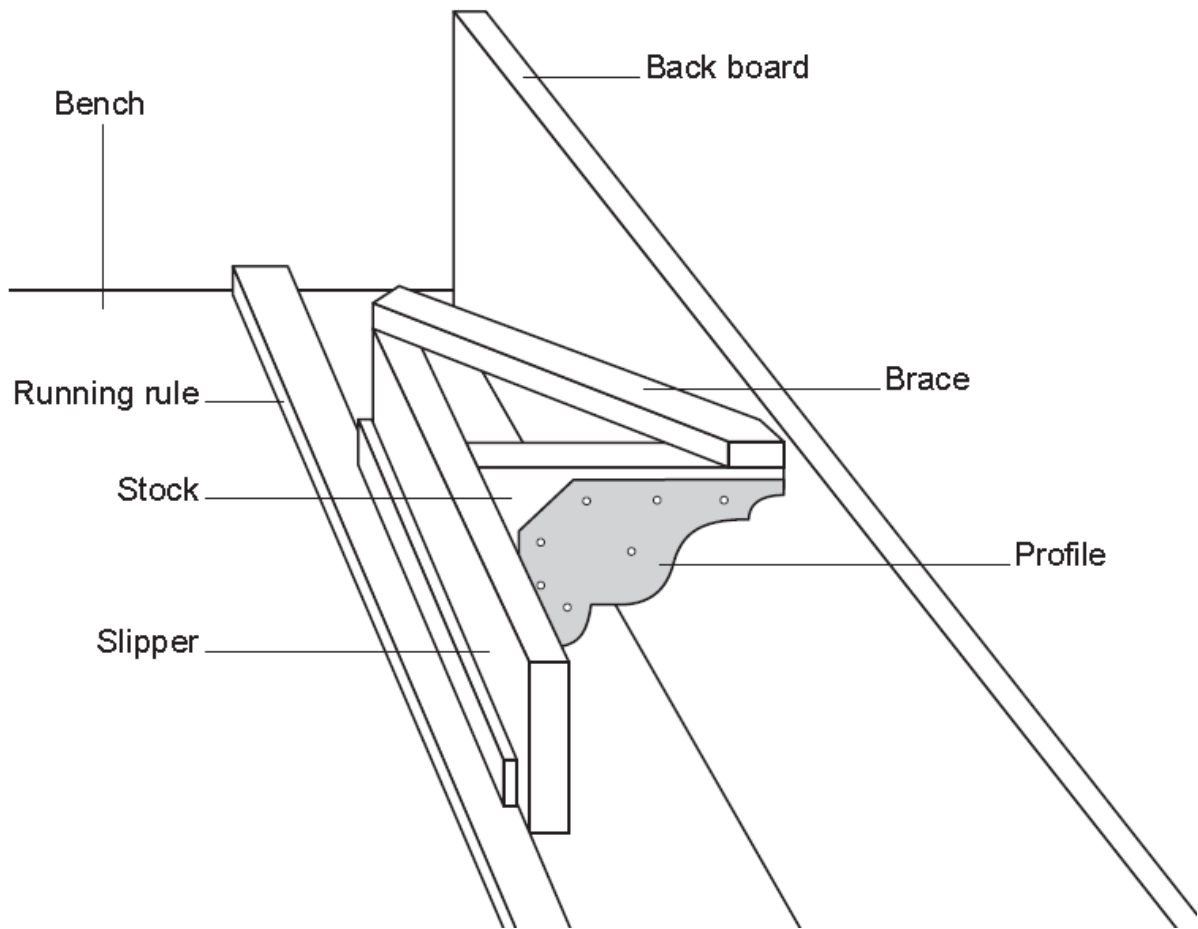
#### Scope of content

##### You will be required to:

- Set up the workbench and fix the backboard
- Form a core
- Run a cornice
- Measure and cut two external mitres
- Fix and stop in two external mitres.

No	Candidate instructions	Achieved	
		Yes	No
1	Select the correct tools, materials and equipment		
2	Prepare work bench ready for running, fix a backing board and running rule (Figure 1)		
3	Run/form a core (1 m length) (Figure 1)		
4	Run cornice over the fixed core (1m length) (Figure 1)		
5	Measure and cut the cornice to the correct length and correct type of mitre		
6	Mix and apply adhesive correctly, without adhesive present to the face of the cast		
7	Correctly position the cornice to the correct projection and depth with all members line-able		
8	Stop in all wall and ceiling lines, free from misses and build up		
9	Ensure all mitres are reinforced and stopped in sharp, members in line		
10	Work safely at all times		
11	Housekeeping; <ul style="list-style-type: none"> <li>• Leave work area clean and tidy</li> <li>• Clean and store away materials correctly (if applicable)</li> <li>• Dispose of waste correctly (if applicable).</li> </ul>		

**Figure 1:** Running a cornice against a backboard



## Knowledge questions

- 1) What is paraffin mixed with?
  - a) Methylated spirit.
  - b) Tallow.
  - c) Shellac.
  - d) Petroleum jelly.
  
- 2) When cutting a mitre on a cornice, what measurement is marked along the ceiling line?
  - a) Girth.
  - b) Depth.
  - c) Span.
  - d) Projection.
  
- 3) What tool is used to form and finish external and internal mitres?
  - a) Gauging trowel.
  - b) External angle trowel.
  - c) Joint rule.
  - d) Timber rule.



## Feedback and action planning form

<b>Candidate name:</b>	
<b>Date:</b>	
<b>Task title:</b>	
<b>Candidate feedback</b>	
<b>Assessor feedback</b>	
<b>Action plan</b>	

**Task 4** Take a squeeze from the finished in-situ cornice

<b>Candidate name</b>	
<b>Date</b>	

**Work scenario:** Your company has asked you to go to site and take a squeeze of a cornice, the template will be used to reproduce the cornice and the casts will be used to replace missing sections and the damaged cornice.

**Assessment method:** This practice task requires you to show case both your practical and knowledge skills when taking a squeeze from an in-situ cornice.

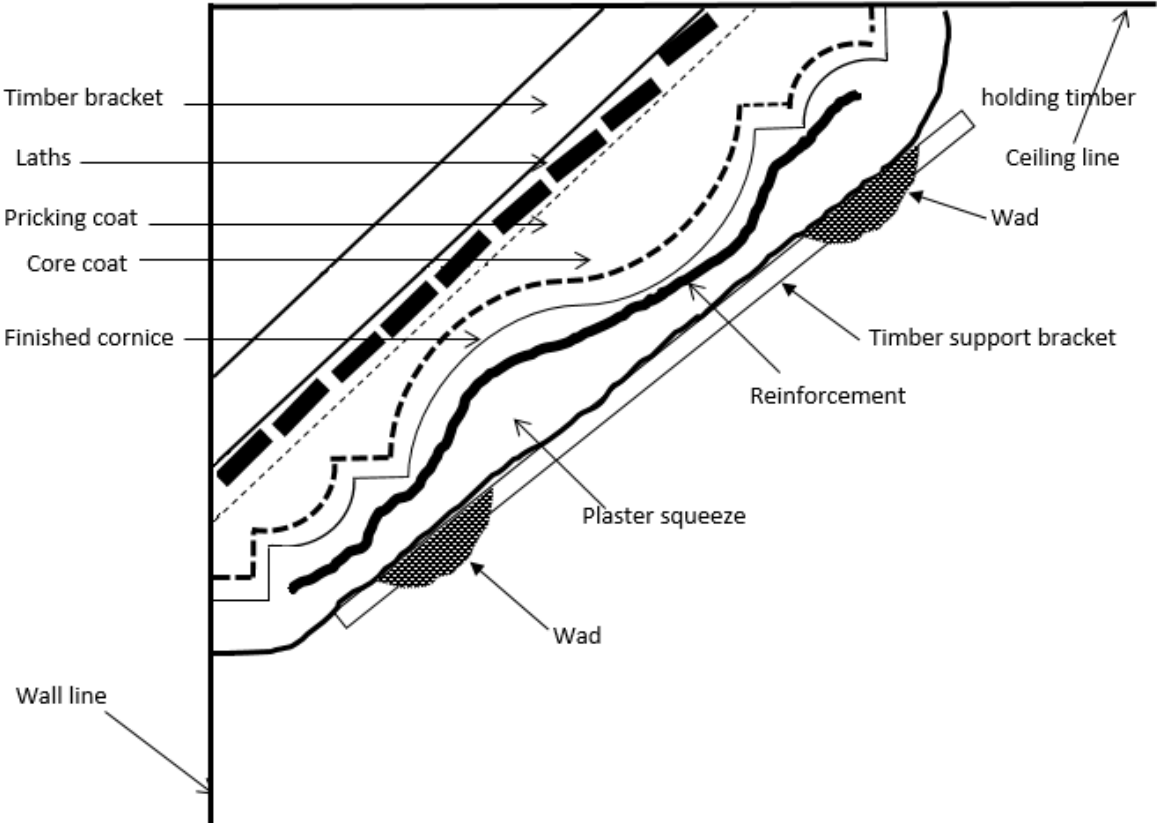
**Scope of content**

**You will be required to:**

- Prepare background surface
- Fix timbers to ceiling and wall areas
- Apply plaster and reinforcements.

No	Candidate instructions	Achieved	
		Yes	No
1	Select the correct tools, materials and equipment		
2	Prepare background surfaces and cornice section		
3	Fix timber support bracket		
4	Apply plaster and reinforcements to form a squeeze ( <b>Figure1</b> )		
5	Transfer squeeze profile to zinc/sheet metal		
6	Work safely at all times		
7	Housekeeping; <ul style="list-style-type: none"> <li>• Leave work area clean and tidy</li> <li>• Clean and store away materials correctly (if applicable)</li> <li>• Dispose of waste correctly (if applicable).</li> </ul>		

**Figure 1:** Taking a squeeze from an in-situ cornice



## Knowledge questions

- 1) What type of reinforcement should be used when taking a plaster squeeze?
  - a) Fibre tape.
  - b) Hessian.
  - c) Paper tape.
  - d) E.M.L.
  
- 2) What type of plaster should be used when taking a squeeze?
  - a) Setting.
  - b) Bonding grade.
  - c) Cement based.
  - d) Casting.
  
- 3) What does the abbreviation HMC stand for?
  - a) Hot Melt Compound.
  - b) High Melting Catalyst.
  - c) Hot Material Compound.
  - d) High Melting Chemical.

## Feedback and action planning form

<b>Candidate name:</b>	
<b>Date:</b>	

<b>Task title:</b>	
--------------------	--

### Candidate feedback

--

### Assessor feedback

--

### Action plan

--

**Task 5** Set out and apply two coat plaster to a curved wall to a given radius

<b>Candidate name</b>	
<b>Date</b>	

**Work scenario:** Your company has asked you to go to site and apply two coat plaster work to a curved wall according to the specification. Your first task is to set out the curved wall to the set radius and apply curved screeds.

**Assessment method:** This practice task requires you to show case both your practical and knowledge skills when accurately setting out and applying dots and screeds.

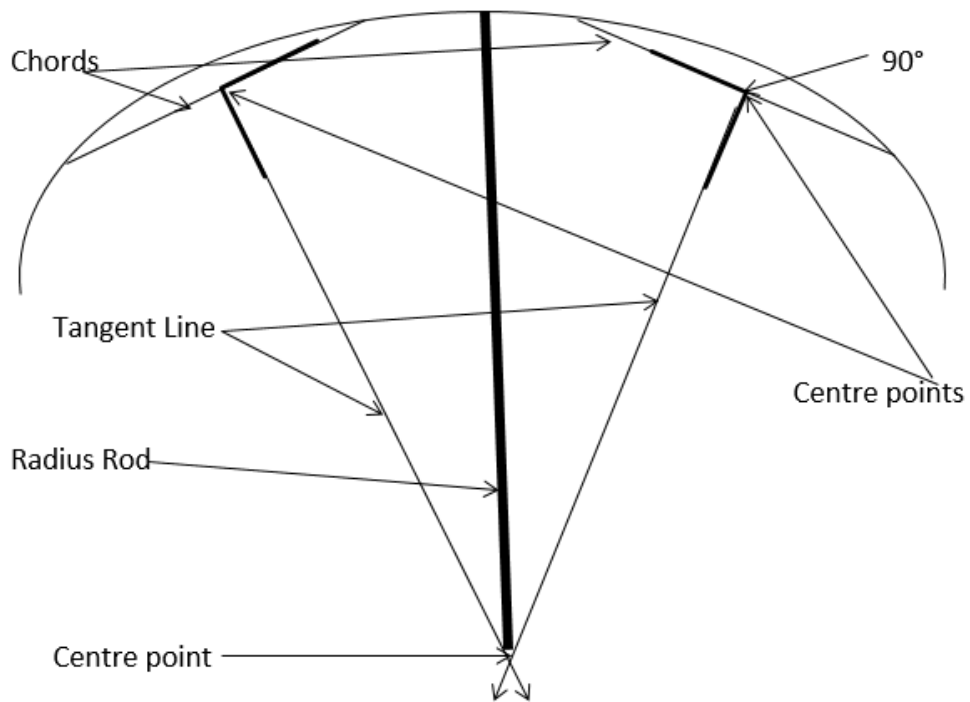
**Scope of content**

**You will be required to:**

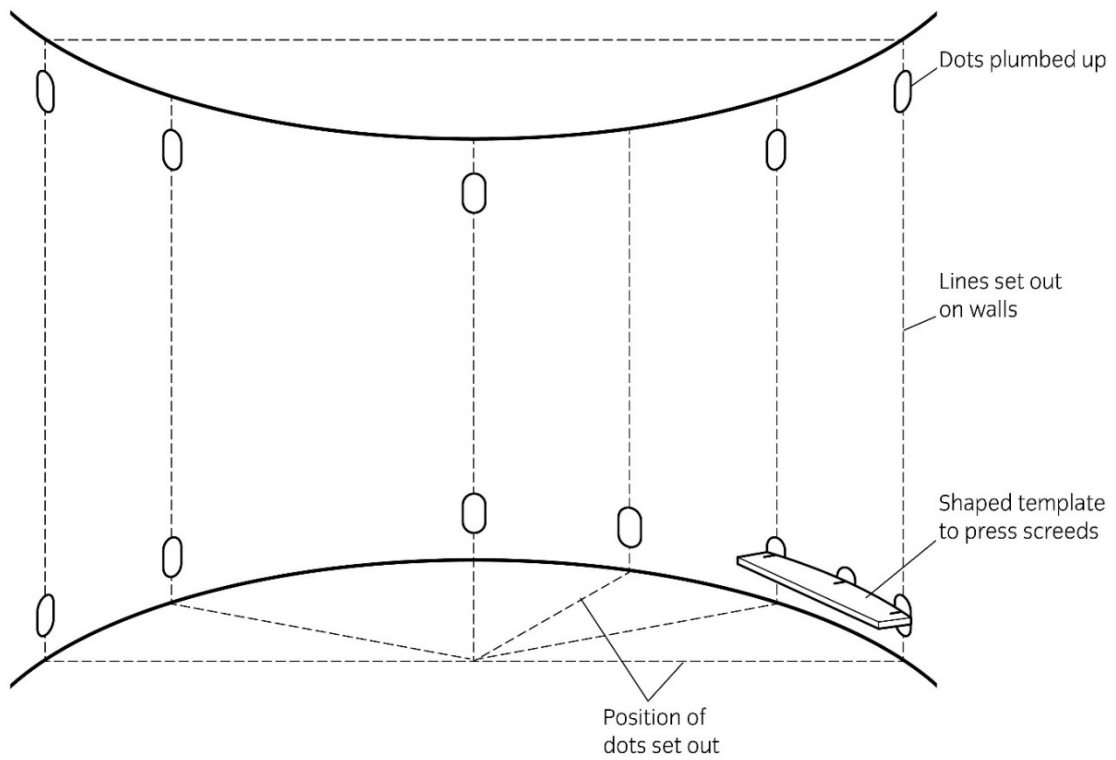
- Set out a curved wall to a set radius
- Produce a curved template
- Form dots and curved screeds.

No	Candidate instructions	Achieved	
		Yes	No
1	Select the correct tools, materials and equipment		
2	Calculate the correct quantities of materials and allow for 10% waste		
3	Prepare the background surface area		
4	Set out and bisect chords, mark tangent lines to centre point (Figure 1)		
5	Fix radius rod, set out and cut curved template (Figure 1)		
6	Form radius template (Figure 2)		
7	Form a base screed using a shaped template or radius rod with up stand (Figure 2/3)		
8	Transfer levels from base screed and apply dots through to ceiling height plumb and linal (Figure 2/3)		
9	Work safely at all times		
10	Housekeeping; <ul style="list-style-type: none"> <li>• Leave work area clean and tidy</li> <li>• Clean and store away materials correctly (if applicable)</li> <li>• Dispose of waste correctly (if applicable).</li> </ul>		

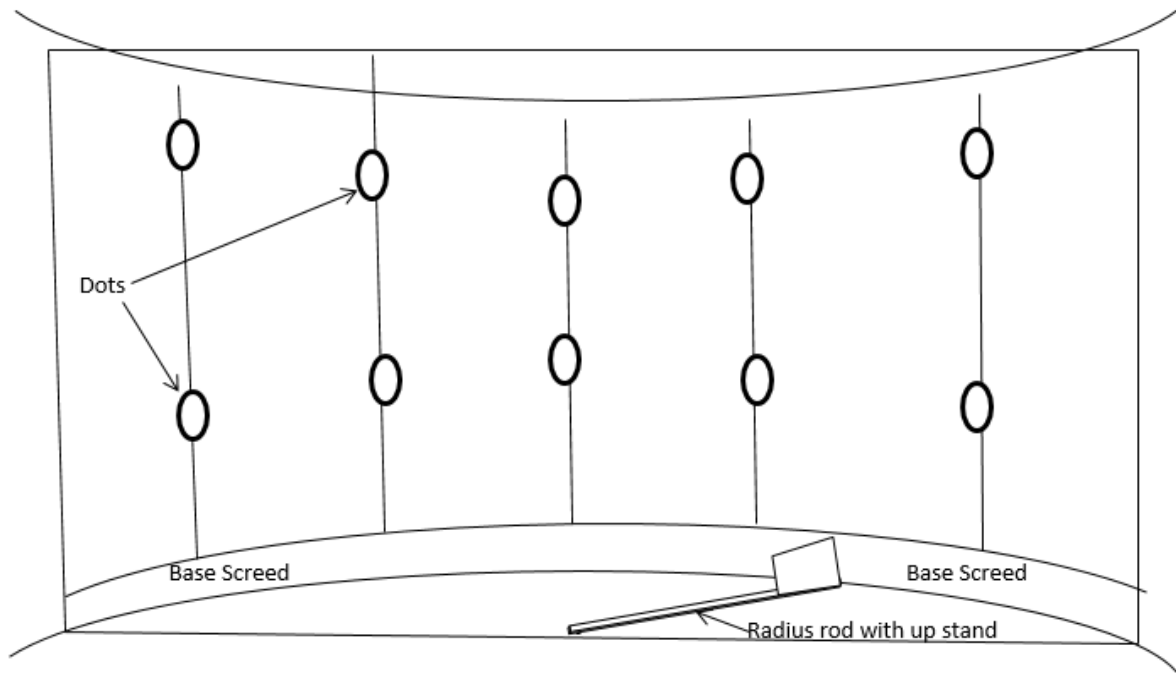
**Figure 1:** Setting out a concave wall



**Figure 2:** Form a base screed using a shaped template



**Figure 3:** Form a base screed using a radius rod and up stand



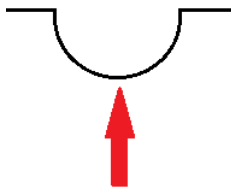


## Knowledge questions

1) What are used to find the centre of a circle?

- a) Tangents.
- b) Screeds.
- c) Chords.
- d) Dots.

2) What name is given to the curved wall shown in the image below?



- a) Concave.
- b) Obtuse.
- c) Convex.
- d) Acute.

3) What is used to set out dots on a concave surface?

- a) Radius rod.
- b) Water level.
- c) Running rule.
- d) Laser level.

## Feedback and action planning form

<b>Candidate name:</b>	
<b>Date:</b>	
<b>Task title:</b>	
<b>Candidate feedback</b>	
<b>Assessor feedback</b>	
<b>Action plan</b>	

**Task 6** Apply and finish two coat plaster work to a curved wall, ready for decoration

<b>Candidate name</b>	
<b>Date</b>	

**Work scenario:** Your company has asked you to go to site and apply two coat plaster work to a curved wall according to the specification.

**Assessment method:** This practice task requires you to show case both your practical and knowledge skills, when applying and ruling backing coats and producing a finish to a curved wall.

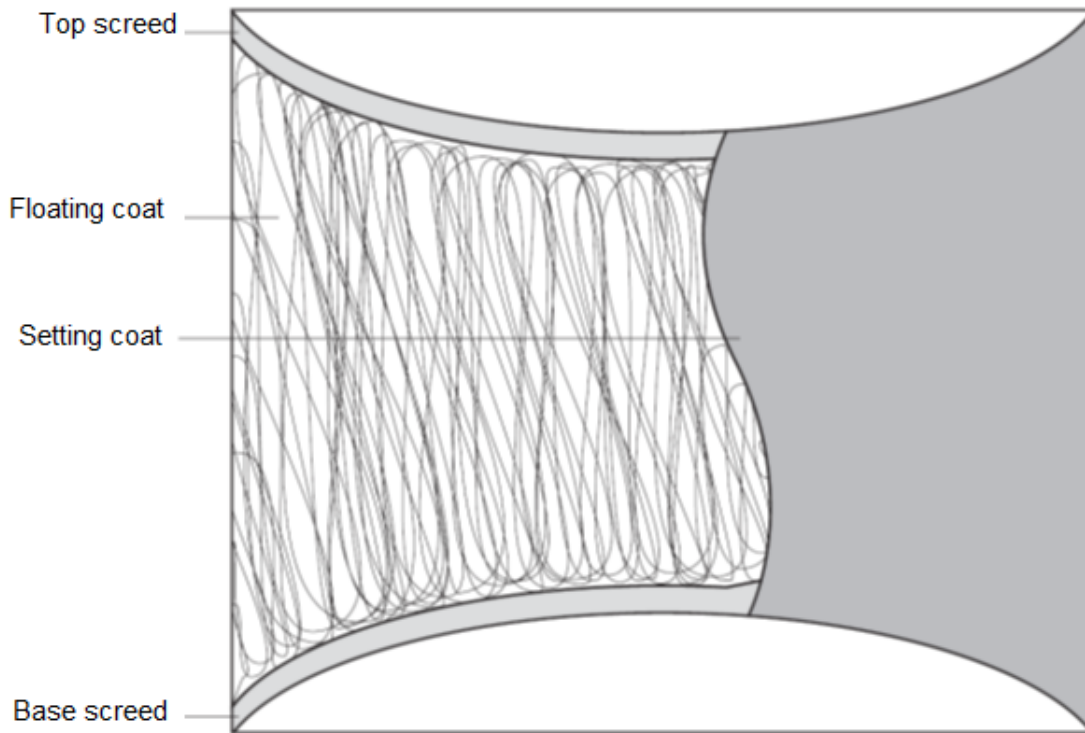
**Scope of content**

**You will be required to:**

- Apply a floating coat
- Produce a uniform key
- Apply a finishing coat
- Produce a smooth finish.

No	Candidate instructions	Achieved	
		Yes	No
1	Select the correct tools and equipment		
2	Calculate the correct quantities of materials and allow for 10% waste		
3	Prepare the background surface area		
4	Prepare a mixing area		
5	Mix and apply floating coat		
6	Produce a uniform key		
7	Mix and apply a setting coat		
8	Produce a smooth finish that is ready for decoration		
9	Work safely at all times		
10	Housekeeping; <ul style="list-style-type: none"> <li>• Leave work area clean and tidy</li> <li>• Clean and store away materials correctly (if applicable)</li> <li>• Dispose of waste correctly (if applicable).</li> </ul>		

**Figure 1-** Apply two coat work to a curved wall



## Knowledge questions

- 1) What is contained within a bonding grade plaster?
  - a) Gypsum, sand and perlite.
  - b) Cement, lime and sand.
  - c) Gypsum, lime and cement.
  - d) Perlite, vermiculite and gypsum.
  
- 2) Which **common** defect occurs when applying a setting coat on a high suction background?
  - a) Sagging.
  - b) Crazeing.
  - c) Blistering.
  - d) Staining.
  
- 3) A bag of bonding covers 3 m<sup>2</sup>. How many bags are required to cover 32 m<sup>2</sup>?
  - a) 11
  - b) 10
  - c) 9
  - d) 8

## Feedback and action planning form

<b>Candidate name:</b>	
<b>Date:</b>	
<b>Task title:</b>	
<b>Candidate feedback</b>	
<b>Assessor feedback</b>	
<b>Action plan</b>	

**Task 7** Apply a three coat system using pre-mixed lightweight plasters and beads to an internal pier or beam

<b>Candidate name</b>	
<b>Date</b>	

**Work scenario:** Your company has asked you to go to site and apply three coat plaster work to an internal pier/beam according to the specification.

**Assessment methods:** This practice task requires you to show case both your practical and knowledge skills when fixing expanded metal lathing and beads when applying three coat plaster work to an internal pier or beam.

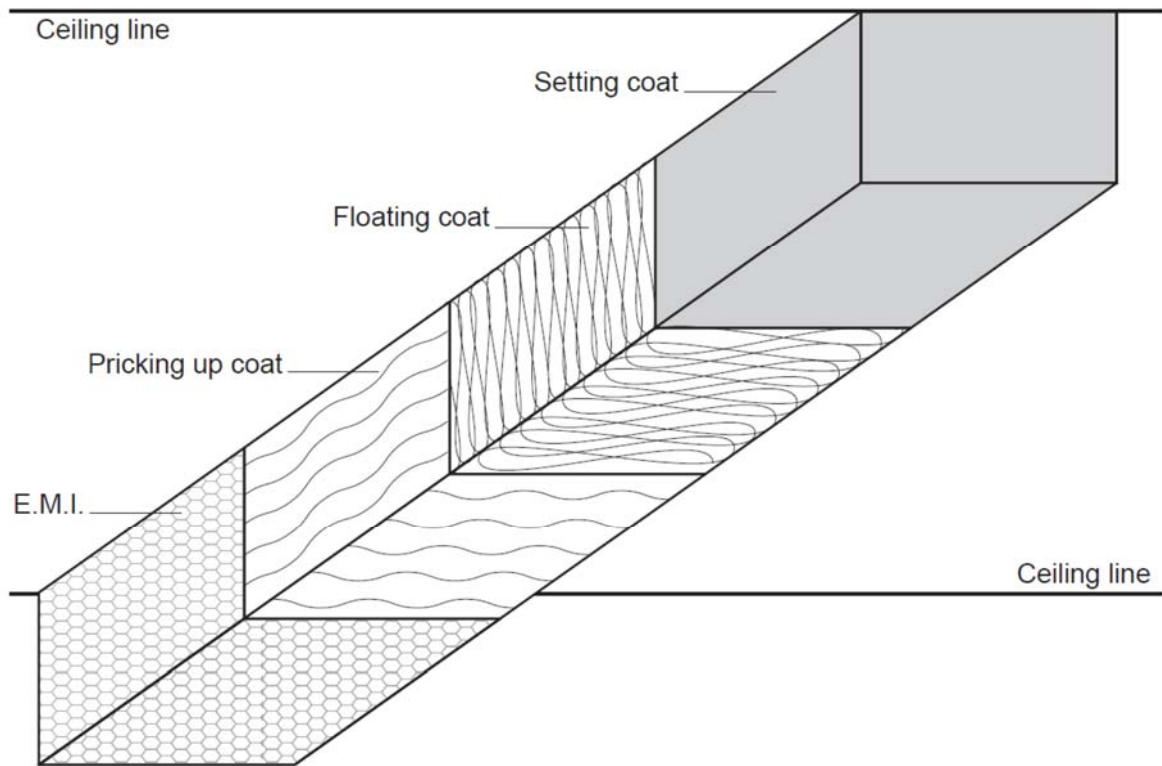
**Scope of content**

**You are required to:**

- Fix expanded metal lath to all sides of a pier or beam
- Apply a pricking up coat with a uniform key
- Fix pre-formed beads
- Apply a floating coat and rule to beads
- Apply a finish coat to a smooth finish.

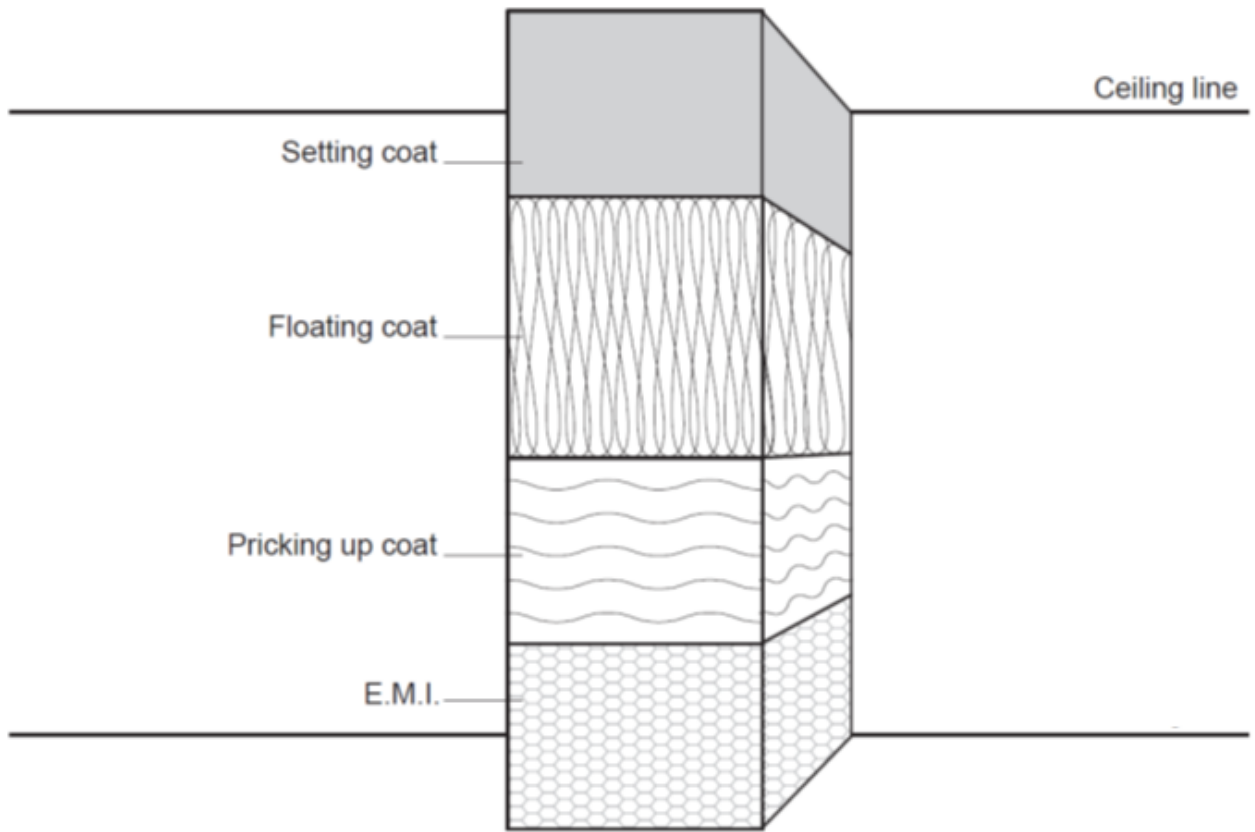
No	Candidate instructions	Achieved	
		Yes	No
1	Select the correct tools, materials and equipment		
2	Calculate the correct quantities of materials and allow for 10% waste		
3	Fix E.M.L with sufficient tension and overlap to given dimensions (Figure 1/2)		
4	Mix a lightweight backing plaster to the correct consistency		
5	Apply a pricking up coat with a consistent coverage and key (Figure 1/2)		
6	Fix pre-formed beads to plumb, level and in line (Figure 1/2)		
7	Apply the floating coat to a flat finish with even consistent key and clean angles (Figure 1/2)		
8	Mix the finishing plaster to the correct consistency		
9	Apply the finishing coat to a troweled finish with clean sharp angles (Figure 1/2)		
10	Work safely at all times		
11	Housekeeping; <ul style="list-style-type: none"> <li>• Leave work area clean and tidy</li> <li>• Clean and store away materials correctly (if applicable)</li> <li>• Dispose of waste correctly (if applicable).</li> </ul>		

**Figure 1** – Timber/metal framed beam





**Figure 2** – Timber/beam framed pillar



## Knowledge questions

- 1) Which term is used to describe the **first** application of plaster to an EML background?
  - a) Scratching up.
  - b) Dubbing out.
  - c) Pricking up.
  - d) Floating out.
  
- 2) What is the **minimum** overlap when joining two sides of E.M.L?
  - a) 50 mm
  - b) 100 mm
  - c) 150 mm
  - d) 200 mm
  
- 3) What type of drawing should be referred to when setting out for a pier or beam?
  - a) Reflected ceiling plan.
  - b) Component drawing.
  - c) Elevation drawing.
  - d) Block plan.

## Feedback and action planning form

<b>Candidate name:</b>	
<b>Date:</b>	
<b>Task title:</b>	
<b>Candidate feedback</b>	
<b>Assessor feedback</b>	
<b>Action plan</b>	

**Task 8** Set out and form hard angles to reveals, returns, bell casts and window heads

<b>Candidate name</b>	
<b>Date</b>	

**Work scenario:** You have been asked to go to site and apply a two coat render system to the exterior of a residential two storey property. The client has insisted on a traditional application and finish, your first task is to form all angles, reveals and return solid.

**Assessment method:** This practice task requires you to show case both your practical and knowledge skills, when forming hard angles, reveals, returns and bell cast beads.

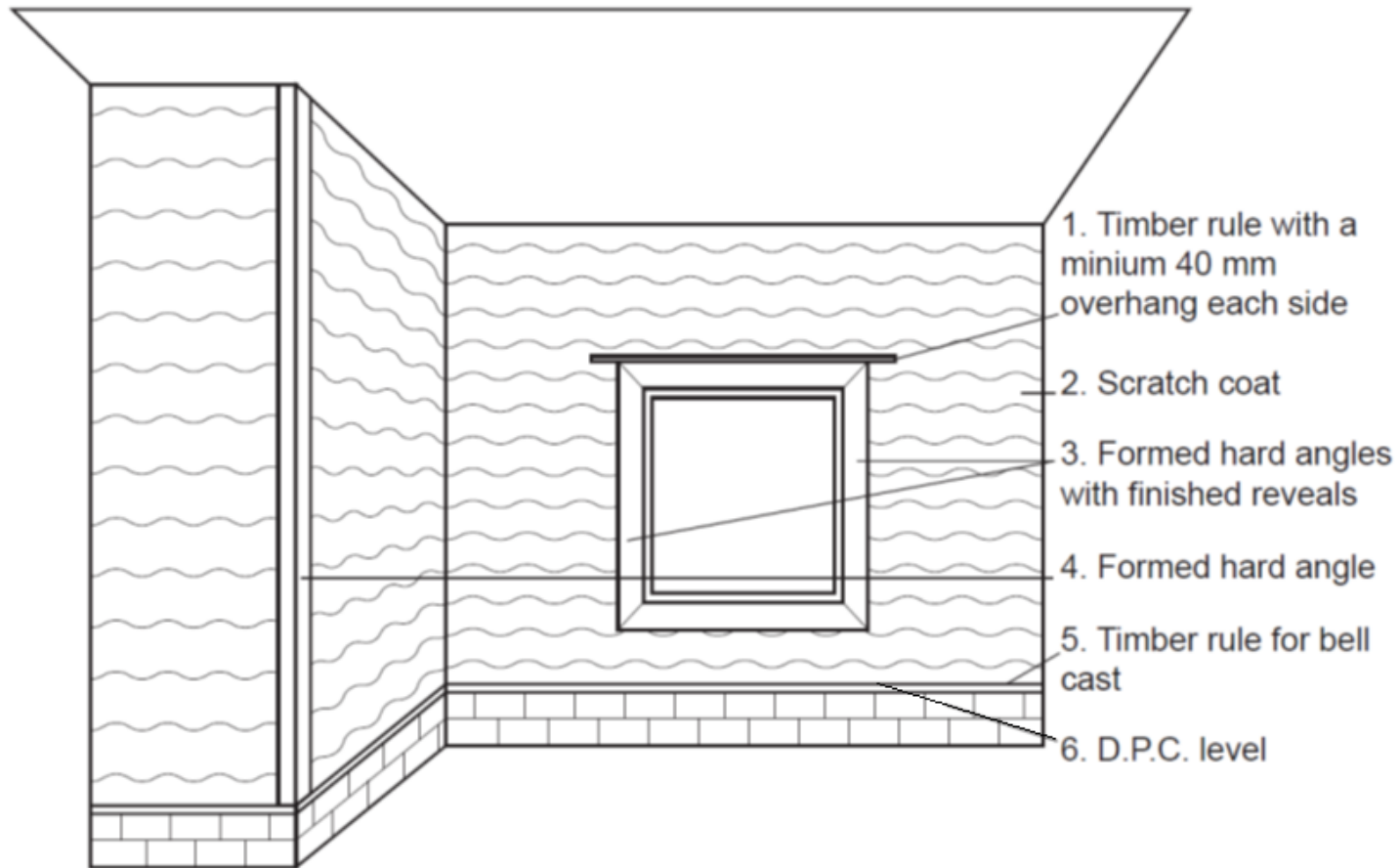
**Scope of content**

**You will be required to:**

- Form hard angles to window openings level and plumb
- Form bell cast beads.

No	Candidate instructions	Achieved	
		Yes	No
1	Select the correct tools, materials and equipment.		
2	Calculate the correct quantities of materials and allow for 10% waste		
3	Prepare the background surface area		
4	Cut rules for openings to correct dimensions		
5	Mix materials to correct ratio and consistency		
6	Apply material to an even consistency		
7	Form external angle to plumb		
8	Form and finish reveals to level, linable and plumb		
9	Position and form bell casts correctly		
10	Work safely at all times		
11	Housekeeping; <ul style="list-style-type: none"> <li>• Leave work area clean and tidy</li> <li>• Clean and store away materials correctly (if applicable)</li> <li>• Dispose of waste correctly (if applicable).</li> </ul>		

**Figure 1** – Set out and form hard angles to reveals, returns, bell casts and window heads





## Knowledge questions

- 1) What is a harling trowel used for?
  - a) Applying ashlar renders.
  - b) Applying an English cottage finish.
  - c) Applying acrylic renders.
  - d) Applying wet and dry dash.
  
- 2) What is the purpose of a bell cast bead?
  - a) To form an external angle.
  - b) To direct rainwater away from the wall.
  - c) To allow for movement between sections of the wall.
  - d) To provide a mechanical key for the top coat.
  
- 3) Where would a damp proof course be located on a building?
  - a) Above ground level.
  - b) Above a window.
  - c) Above lead flashing.
  - d) Above a door way.

## Feedback and action planning form

<b>Candidate name:</b>	
<b>Date:</b>	
<b>Task title:</b>	
<b>Candidate feedback</b>	
<b>Assessor feedback</b>	
<b>Action plan</b>	



**Task 9** Apply dry dash and rough cast finishes to a prepared scratch coat background

<b>Candidate name</b>	
<b>Date</b>	

**Work scenario:** You have been asked to go to site and apply a three coat render system to the exterior of a residential two storey property. The client has requested a traditional dry dash/rough cast finish.

**Assessment methods:** This practice task requires you to show case both your practical and knowledge skills when applying base and top coats to the external facades to buildings to create a waterproof finish.

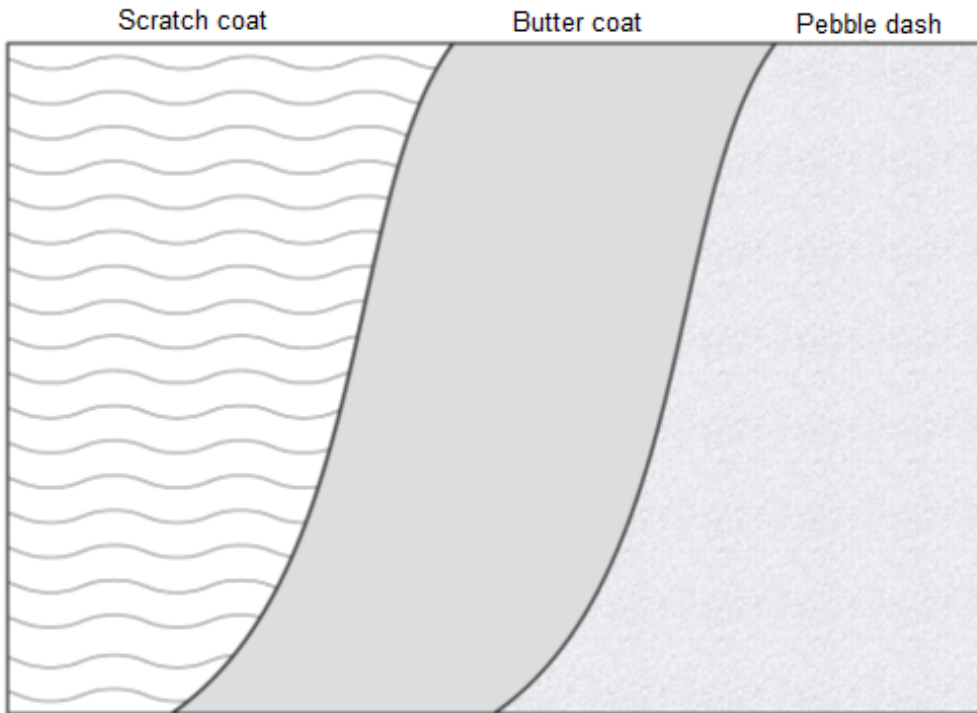
**Scope of content**

**You will be required to:**

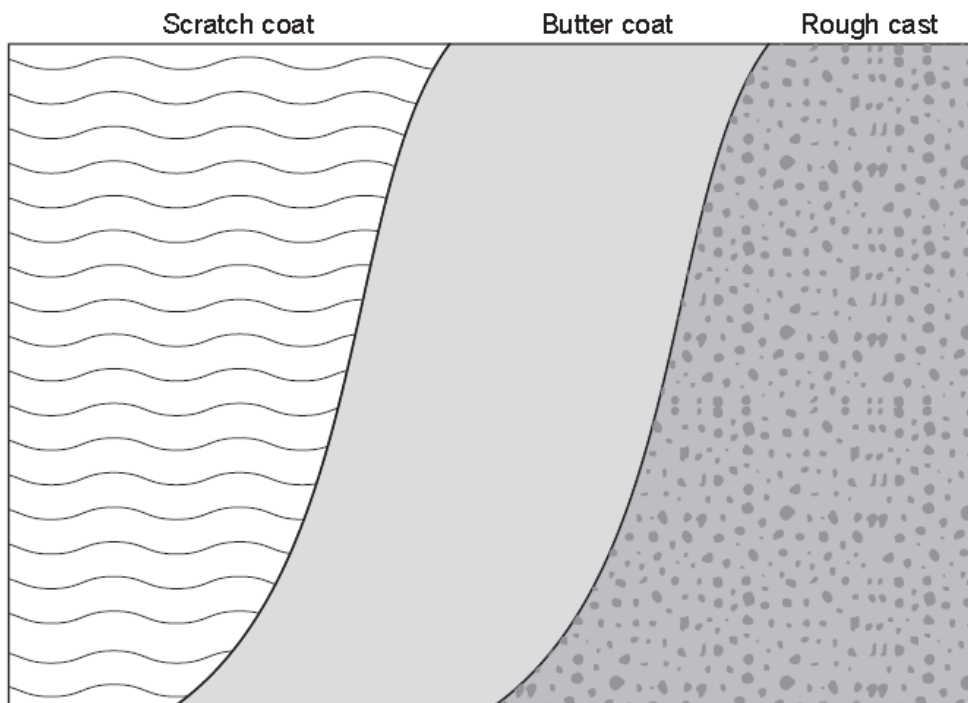
- Prepare background surface
- Produce a dry dash finish
- Produce a rough cast finish.

No	Candidate instructions	Achieved	
		Yes	No
1	Select the correct tools and equipment		
2	Prepare the background surface area		
3	Mix and apply an even flat butter coat		
4	Apply a uniform dry dash finish (Figure 1)		
5	Mix the rough cast to a uniform consistency		
6	Apply a uniform rough cast finish (Figure 2)		
7	Work safely at all times		
8	Housekeeping; <ul style="list-style-type: none"> <li>• Leave work area clean and tidy</li> <li>• Clean and store away materials correctly (if applicable)</li> <li>• Dispose of waste correctly (if applicable).</li> </ul>		

**Figure 1** – Dry dash finish



**Figure 2** – Rough cast finish



## Knowledge questions

- 1) What part of a window opening is a bell cast bead fitted to?
  - a) Reveal.
  - b) Sill.
  - c) Wall plate.
  - d) Head.
  
- 2) What is incorporated into the mix when rough casting?
  - a) Stone aggregate.
  - b) Silver sand.
  - c) Granite dust.
  - d) Marble flour.
  
- 3) What term is given to the top coat of render before applying the pebble dash?
  - a) Scratch coat.
  - b) Butter coat.
  - c) Picking up coat.
  - d) Float coat.

## Feedback and action planning form

<b>Candidate name:</b>	
<b>Date:</b>	
<b>Task title:</b>	
<b>Candidate feedback</b>	
<b>Assessor feedback</b>	
<b>Action plan</b>	

**Task 10** Set out and produce ashlar blockwork finishes to a plain face render background  
Set out and produce quoins (**optional**)

<b>Candidate name</b>	
<b>Date</b>	

**Work scenario:** You have been asked to go to site and apply a two coat render system to the exterior gable wall of a residential two storey property. The client has requested an Ashlar block work finish with quoins.

**Assessment method:** This practice task requires you to show case both your practical and knowledge when applying and setting out decorative ashlar finishes to the external façade of a building.

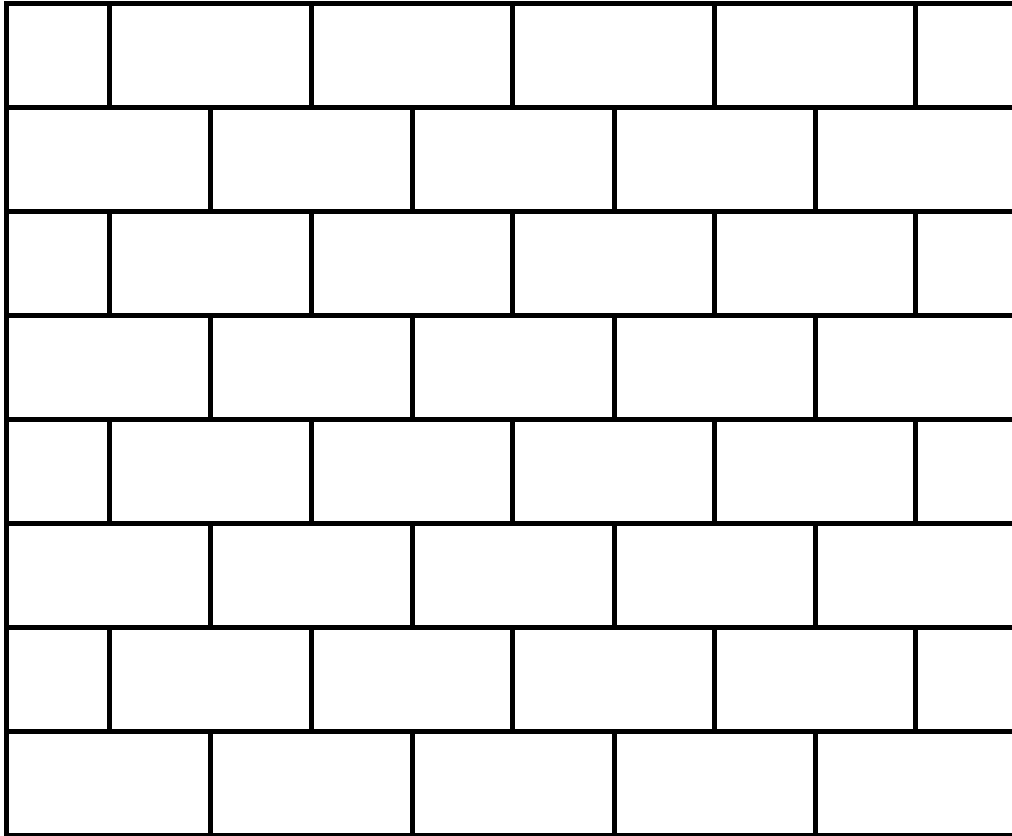
**Scope of content**

**You be required to:**

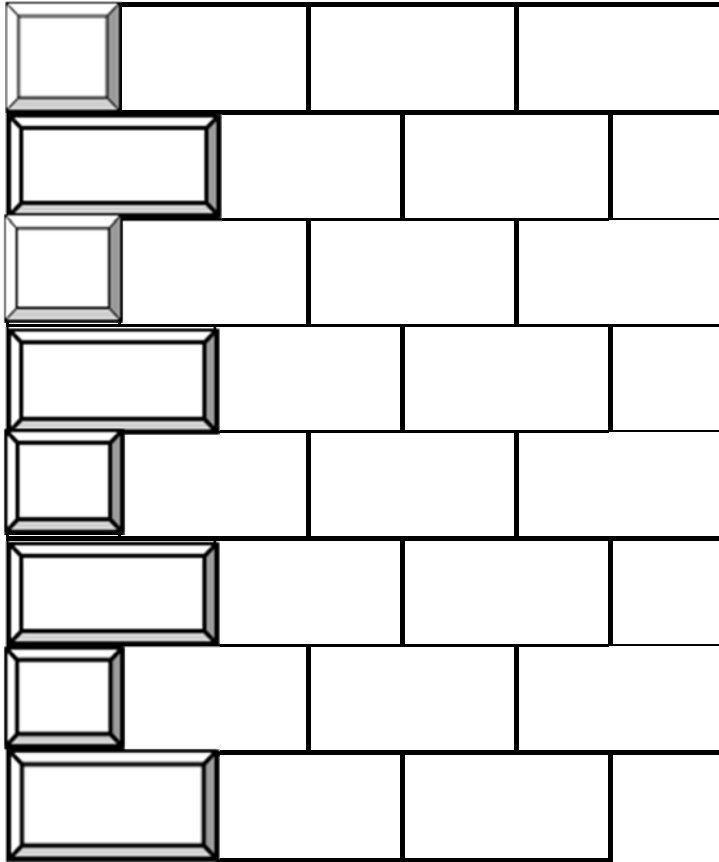
- Set out to given dimensions on a flat render background
- Mark out and produce an ashlar block finish
- Mark out and produce quoins (**optional**).

No	Candidate instructions	Achieved	
		Yes	No
1	Select the correct tools, materials and equipment		
2	Set out ashlar block work from the centre line (Figure 1)		
3	Divide height into equal sized blocks		
4	Divide length into correct block bond		
5	Mark out to a uniform depth (Figure 1)		
6	Set out quoins (Figure 2: <b>optional</b> )		
9	Work safely at all times		
10	Housekeeping; <ul style="list-style-type: none"> <li>• Leave work area clean and tidy</li> <li>• Clean and store away materials correctly (if applicable)</li> <li>• Dispose of waste correctly (if applicable).</li> </ul>		

**Figure 1:** Ashlar Finish



**Figure 2:** Quoins



## Knowledge questions

- 1) What is the purpose of SBR when rendering?
  - a) To slow down the set.
  - b) To increase adhesion.
  - c) To increase the set.
  - d) To improve workability.
  
- 2) What type of rendering bead allows for movement and prevents cracking?
  - a) Stop.
  - b) Angle.
  - c) Expansion.
  - d) Bell.
  
- 3) What does external rendering prevent?
  - a) Water egress.
  - b) Rising damp.
  - c) Algae growth.
  - d) Efflorescence.



## Feedback and action planning form

<b>Candidate name:</b>	
<b>Date:</b>	
<b>Task title:</b>	
<b>Candidate feedback</b>	
<b>Assessor feedback</b>	
<b>Action plan</b>	

**Task 11** Apply a Tyrolean finish to a plain face render background

<b>Candidate name:</b>	
<b>Date:</b>	

**Work scenario:** You have been asked to go to site and apply a three coat render system to the exterior of a residential two storey property. The client has insisted on a traditional tyrolean finish.

**Assessment methods:** This practice task requires you to show case both your practical and knowledge skills when applying a pre-coloured decorative waterproof finish to the external facades of buildings.

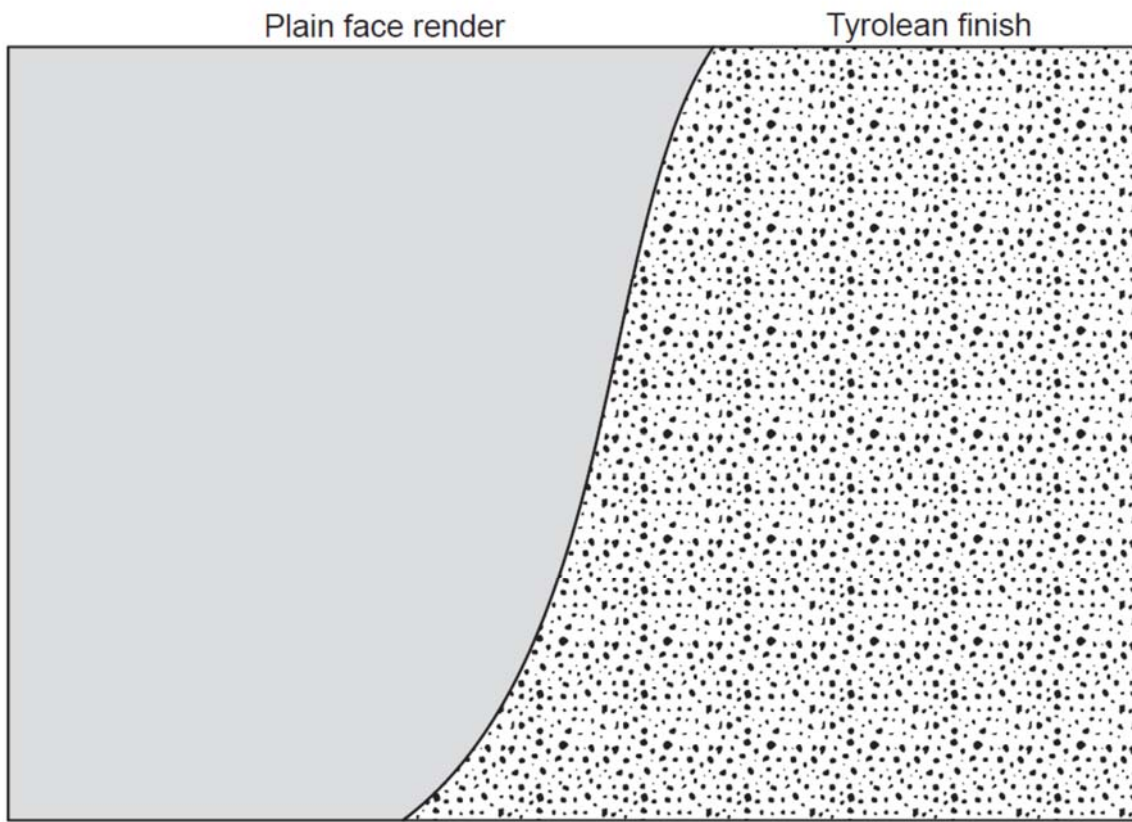
**Scope of content**

**You will be required to:**

- Prepare the background surface
- Prepare the mixing area
- Produce a uniform Tyrolean finish.

No	Candidate instructions	Achieved	
		Yes	No
1	Select the correct tools, materials and equipment		
2	Prepare the background surface area		
3	Prepare the mixing area		
4	Calculate the correct quantities of materials and allow for 10% waste		
5	Mix Tyrolean to a uniform consistency		
6	Work safely at all times		
7	Housekeeping; <ul style="list-style-type: none"> <li>• Leave work area clean and tidy</li> <li>• Clean and store away materials correctly (if applicable)</li> <li>• Dispose of waste correctly (if applicable).</li> </ul>		

**Figure 1:** Tyrolean finish



## Knowledge questions

- 1) What type of base coat should a tyrolean finish be applied to?
  - a) Smooth render.
  - b) Rough cast.
  - c) Pebble dash.
  - d) Keyed render.
  
- 2) How should tyrolean finish be applied?
  - a) By hand.
  - b) By brush.
  - c) By machine.
  - d) By trowel.
  
- 3) Which is a benefit of a tryolean finish?
  - a) It never has to be painted.
  - b) It improves thermal efficiency.
  - c) It reduces noise transfer.
  - d) It is quicker to apply.

## Feedback and action planning form

<b>Candidate name:</b>	
<b>Date:</b>	
<b>Task title:</b>	
<b>Candidate feedback</b>	
<b>Assessor feedback</b>	
<b>Action plan</b>	

**Task 12** Apply premixed acrylic **OR** silicone render finishes to a plain face render and backing coats

<b>Candidate name:</b>	
<b>Date:</b>	

**Work scenario:** You have been asked to go to site and apply a modern render system to the exterior of a residential two storey modern property.

**Assessment method:** This practice task requires you to show case both your practical and knowledge skills when applying a premixed and pre-coloured acrylic **OR** silicone render finish to the external facades of buildings.

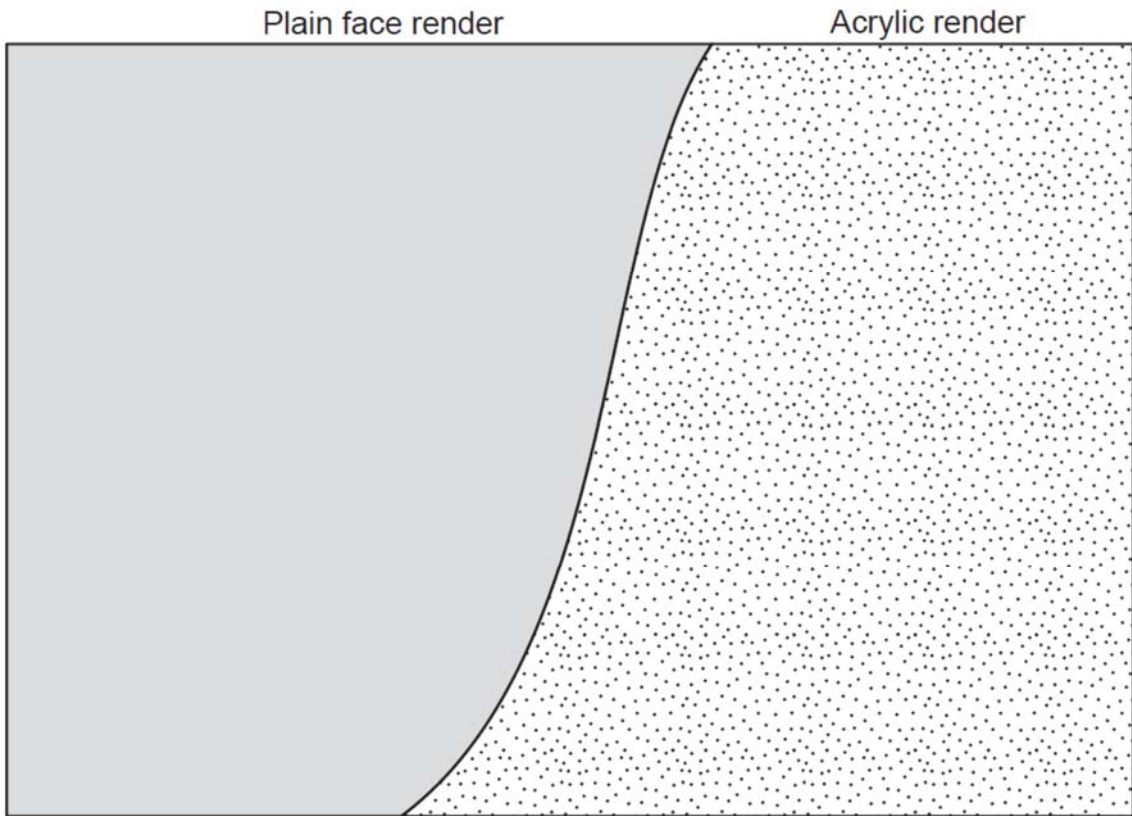
### Scope of content

#### You will be required to:

- Prepare the background surface
- Prepare the mixing area
- Produce a uniform scrapped finish.

No	Candidate instructions	Achieved	
		Yes	No
1	Select the correct tools, materials and equipment		
2	Prepare the mixing area		
3	Mix acrylic render to a uniform consistency		
4	Apply the render to the correct depth		
5	Produce a uniformed scrapped textured finish (Figure 1)		
6	Work safely at all times		
7	Housekeeping; <ul style="list-style-type: none"> <li>• Leave work area clean and tidy</li> <li>• Clean and store away materials correctly (if applicable)</li> <li>• Dispose of waste correctly (if applicable).</li> </ul>		

**Figure 1:** Acrylic render



## Knowledge questions

- 1) What term is given to block work grinning through the face of a silicone render finish?
  - a) Ghosting.
  - b) Curing.
  - c) Cockling.
  - d) Shelling.
  
- 2) What is applied within the base coat?
  - a) Stainless steel mesh.
  - b) Nylon mesh.
  - c) EML.
  - d) Riblath.
  
- 3) Which is a benefit of an acrylic thin coat render?
  - a) It is rigid.
  - b) It is porous.
  - c) It is breathable.
  - d) It is flexible.



## Feedback and action planning form

<b>Candidate name:</b>	
<b>Date:</b>	
<b>Task title:</b>	
<b>Candidate feedback</b>	
<b>Assessor feedback</b>	
<b>Action plan</b>	

## ASSESSOR GUIDANCE

These practice tasks are designed for the candidates to make use of the 'tool kit' of knowledge, understanding and skills they will gain during their teaching and learning during this qualification in order to tackle problems/ tasks/ challenges.

Candidates are provided with a set of tasks, which can be taken in any order. The candidates have to reach into their knowledge and skills to independently select the correct processes, skills, materials, approaches to take etc, drawing on the full range of knowledge and understanding from across the qualification to make good decisions that will achieve an end result that is fit for the specified purpose.

These formative tasks will allow candidates to be supported in learning how to independently use the learning they have covered so far, drawing this together in a similar way, so they are familiar with the format, conditions and expectations of the practical assignment that they will sit at the end of this qualification.

Assessors have the option of asking candidates to complete a risk assessment, method statement or resource checklist, but this is not compulsory. Generic forms for these can be found in the appendix section.

## Guidance on tasks

### Resources

Centres will have well equipped workshops with comprehensive range of hand and portable power tools that meet current industry standards. All powered equipment should be well maintained and PAT certified. Centres will have special designated areas within their workshop (cubicles or project area) allowing candidates to practice the requirements of the unit and practice tasks.

### Health and safety

Candidates should not be entered for assessment without being clear of the importance of working safely, and practice of doing so. The tutor must immediately stop a task if a candidate works unsafely and give the candidate feedback on why they were stopped.

Where it is appropriate candidates must be supervised when operating machinery.

### Observation

Candidates must be observed carrying out these practice tasks and notes must be taken on the quality of performance along with any other aspect of performance that will support giving feedback to the candidate.

### Preparation

During the formative practice tasks, tutors should routinely point out good or poor performance during the learning period, and through formative assessment. Candidates should be encouraged to do the best they can and be made aware of the difference between these formative assessments and the summative assessments.

## Knowledge Questions answer keys

**Task 1** Construct an in-situ running mould

Question	Correct key
1	B
2	A
3	D

**Task 2** Fix bracketing and run an in-situ cornice.

Question	Correct key
1	C
2	A
3	B

**Task 3** Run a cornice and fix to external mitres

Question	Correct key
1	B
2	D
3	C

**Task 4** Take a squeeze from the finished in-situ cornice

Question	Correct key
1	B
2	D
3	A

**Task 5** Set out and apply two coat plaster to a curved wall to a given radius

Question	Correct key
1	C
2	C
3	A

**Task 6** Apply and finish two coat plaster work to a curved wall, ready for decoration

Question	Correct key
1	D
2	B
3	A

**Task 7** Apply a three coat system using pre-mixed lightweight plasters and beads to an internal pier or beam.

Question	Correct key
1	C
2	B
3	A

**Task 8** Set out and form hard angles to reveals, returns, bell casts and window heads.

Question	Correct key
1	D
2	B
3	A

**Task 9** Apply dry dash and rough cast finishes to a prepared scratch coat background.

Question	Correct key
1	C
2	A
3	B

**Task 10** Set out and produce ashlar blockwork finishes to a plain face render background.  
Set out and produce quoins. **(optional)**

Question	Correct key
1	B
2	C
3	A

**Task 11** Apply a Tyrolean finish to a plain face render background.

Question	Correct key
1	A
2	C
3	D

**Task 12** Apply Acrylic **OR** silicone render finishes to a plain face render and backing coats

Question	Correct key
1	A
2	B
3	D



<b>Materials</b>	<b>Quantity</b>
<i>eg paving slabs</i>	<i>10</i>

<b>Personal Protective Equipment (PPE)</b>	<b>Quantity</b>
<i>eg safety harness</i>	<i>1</i>



# Risk assessment form



<b>Candidate Name</b>	<b>SEVERITY (S):</b> Degree of harm which may be caused (including numbers affected) 1 = Minor Injury 2 = Major Injury 3 = Fatality	<b>LIKELIHOOD (L):</b> Probability that event will occur 1 = Remote 2 = Possible 3 = Likely	<b>RISK RATING (RR):</b> Severity x Likelihood 1-2 = Low 3-4 = Medium 6-9 = High
-----------------------	---	---	--

Date	Task title	Hazard	Existing Controls	S (1-3)	L (1-3)	RR (S x L)	Actions needed
18 July 2013	Apply materials and fix tiles to surfaces	Chemical based adhesives	PPE	1	2	2	Implement sign off sheet to ensure PPE is worn

		Likelihood		
		Unlikely	Possible	Very likely
Severity	1 Slight / minor injuries / minor damage	1	2	3
	2 Medium injuries / significant damage	2	4	6
	3 Major injury / extensive damage	3	6	9

#### Likelihood

3 = Very likely

2 = Possible

1 = Unlikely

#### Severity

3 = Major injury / extensive damage

2 = Medium injury / significant damage

1 = Slight / minor damage

#### Key:
















1 = Low risk, action should be taken to reduce the risk if reasonably practicable

2, 3, 4 = Medium risk, is a significant risk and would require an appropriate level of control measures.

6 & 9 = High risk, should not be undertaken without prior agreement.

# Method statement

<b>Department/Location:</b>		
<b>Risk Assessment No.</b>		
<b>Description of the task/Activity:</b>		
<b>Personnel Involved:</b>	<b>Name</b>	<b>Role/Trade</b>
<b>Key Plant &amp; Tools:</b>		
<b>Key Materials:</b>		
<b>Other Essential Equipment:</b> (ie access platforms/winches/ladders, etc)		
<b>Specific Identified Residual Hazards:</b> (or refer to the task specific risk assessment(s))		
<b>Specific Staff Training</b>		
<b>Sequence of Operations:</b> (include sketches if required)		

<b>Hazardous Substances:</b> (Attach MSDS if required)  <b>Applicable:</b>							
	Very Toxic	Harmful/Irritant	Corrosive	Dangerous For the environment	Oxidising	Highly flammable	Explosives
<b>Required Personal Protective Equipment:</b>							
	Safety Boots	Hard Hats	Safety Gloves	Hearing Protection	Eye Protection	Respiratory Protection	Hi Viz Protective Clothing
<b>Emergency Procedures:</b>							
	<b>First Aid Facilities:</b>	<b>Name of On-Site First Aider:</b>					
		<b>First Aid Box Location:</b>					
		<b>Location of Nearest Hospital:</b>					
<b>Other information &amp; Comments</b>							

# Declaration of Authenticity

Candidate name

Candidate number

---

Centre name

---

Centre number

---

## Candidate:

**I confirm that all work submitted for this synoptic assignment is my own, and that I have acknowledged all sources I have used.**

Candidate signature

Date

## Tutor:

**I confirm that all work was conducted under conditions designed to assure the authenticity of the candidate's work, and am satisfied that, to the best of my knowledge, the work produced is solely that of the candidate.**

---

Tutor/assessor signature

Date

## Assessment feedback form

Candidate name

Candidate number

Assessor name

Date of assessment

Task / AO	Feedback

Assessor signature and date: