

**T Level Technical Qualification in
Maintenance, Installation and
Repair for Engineering and
Manufacturing (8712-34)**

**Maintenance Engineering
Technologies: Control and
Instrumentation (314)**

**Practical Assignment
Sample Assessor Pack**

First teaching from September 2022

Version 2.0

Version and date	Change detail	Section
1.1 Jan 2023	OS title amendment	Front cover
2.0 April 2024	Demonstration of system functionality moved from Task 4 to Task 2, including the requirement of an assessor observation.	Task specific guidance, Task 2 and Task 4.
	Marking grids – Assessment Themes – Systems and components, Working with faults, Reviewing and reporting.	
	Recommended assessor to candidate ratios reduced to 3.	General task guidance
	Additional guidance regarding restricting the use of and access to systems prior to system demonstration.	Task Specific Guidance Centre Guidance

Contents

1. Assessment	4
Performance outcomes	5
Grade descriptors	6
2. Assignment brief	7
3. Tasks	9
General task guidance	9
Task specific guidance	12
Task 1 – Plan and prepare for the maintenance activities	15
Task 2 – Perform the maintenance activities	16
Task 3a – Review and report the maintenance activities	18
Task 3b – Peer review	19
Task 4 – Complete handover	21
4. Centre guidance	23
5. Marking	30
Marking grid	33
Assessment theme - Health and safety	33
Assessment theme – Planning and preparation	37
Assessment theme – Systems and components	40
Assessment theme – Working with faults	44
Assessment theme – Reviewing and reporting	47
6. Links to Maths, English and Digital Skills	51
7. Peer Review Form	52
8. Declaration of authenticity	53
9. Candidate Record Form (CRF) – Exemplar	54

1. Assessment

The assessment for this component consists of a practical assignment that includes an assignment brief and then a number of tasks for the candidate to complete. Tasks are assessed by assessment themes that cover a range of knowledge and skills from the performance outcomes. They are designed to allow judgement of the candidate to be made across different categories of performance.

The assessment for this component has been allocated a set number of marks against each assessment theme, based on weightings recommended by stakeholders of the qualification. This mark allocation remains the same for all versions of the assessments, ensuring consistency across assessment versions and over time.

Performance outcomes

The weightings for each performance outcome will remain the same for every version of the practical assignment. This ensures the appropriate depth and breadth of knowledge and skills for each specialism can be reliably assessed in every version and meets the needs of industry while keeping comparability between each assessment over time.

Performance outcome	Typical knowledge and skills	Weighting
PO2 Analyse requirements, specifications and technical information to enable the delivery of successful maintenance, installation, servicing and repair of control and instrumentation technology, systems, and equipment.	Interpret requirements of a brief through analysis and interrogation of available information sources and formats, including technical representations. Consider all relevant aspects of a brief, challenging and confirming expectations including risks. Select and use techniques and technologies that will assist in the analysis of information available.	10%
PO3 Plan and prepare the maintenance, installation, servicing and repair of control and instrumentation technology, systems and equipment, taking into account the specific requirements and context.	Plan to meet the requirements of a brief effectively with consideration of required resources and technology. Identify and mitigate potential issues prior to maintenance, installation, servicing and repair activities through risk assessment and management. Prepare the work area, including required tools and equipment for maintenance, installation, servicing and repair activities.	20%
PO4 Perform relevant maintenance, installation, servicing and repair of control and instrumentation technology, systems, and equipment, using appropriate techniques and procedures to achieve the required quality outcomes and solutions.	Maintain, install and repair control and instrumentation systems, equipment, and components. Use diagnostic and measurement techniques, tools and equipment safely and efficiently. Locate faults and carry out maintenance and repair activities efficiently. Remove, repair and replace components in line with best practice to complete maintenance, installation, servicing and repair tasks. Re-commission and return control and instrumentation systems to service, and reinstate the work area following maintenance, installation and repair activities.	40%
PO5 Review and evaluate activities to help improve workplace systems and processes associated with maintenance, installation, servicing and repair of control and instrumentation technology, systems, and equipment, demonstrating commercial awareness and accountability.	Deal with issues and problems quickly and efficiently, escalate issues in line with correct lines of reporting. Monitor work to ensure efficiency, and safety at all times. Carry out quality monitoring and assurance checks to review processes. Make positive contributions when responding constructively to feedback from others.	20%
PO6 Communicate control and instrumentation maintenance, installation, servicing and repair information, proposals and solutions, producing, recording and explaining relevant technical information.	Record and amend technical information, data, risks and issues to support maintenance, installation and repair activities. Use different techniques to communicate technical information effectively with consideration of audience and format, and complete handover procedures.	10%

Grade descriptors

To achieve a pass (threshold competence), a candidate will typically be able to:

Interpret technical information, plan, assess risk and follow safe working methods appropriately when applying practical skills to an acceptable standard to satisfy the requirements of the brief.

Adequately prepare working areas to allow safe working, acknowledging potential risks and applying acceptable housekeeping techniques during tasks.

Demonstrate basic technical skills for diagnosing components, assemblies and sub-assemblies to complete maintenance, installation and repair activities, in line with the requirements of the brief.

Demonstrate adequate skills using tools and equipment for control and instrumentation maintenance, installation and repair, ensuring safe isolation, removal and replacement of components.

Demonstrate basic knowledge and understanding of the principles and processes required for disassembly, repair, configuration and re-assembly of control and instrumentation systems, ensuring that most tolerances and calibrations are in-line with specification.

Work safely showing an understanding and suitable level of awareness in the preparation and application of processes, selection and use of tools, equipment, materials and components for maintenance, installation and repair activities.

Mostly use industry and technical terminology accurately across different communication methods with some consideration of technical and non-technical audiences.

To achieve a distinction, a candidate will typically be able to:

Competently and thoroughly interpret technical information, applying technical skills to plan, assess risk and follow safe working methods to practical tasks and procedures to an exemplary standard in response to the requirements of the brief, working systematically, logically and efficiently, producing an excellent quality of work that meets regulations and standards.

Thoroughly prepare working areas, mitigating potential risks prior to commencing tasks and consistently apply exemplary housekeeping techniques during tasks that allow safe and efficient working.

Demonstrate comprehensive technical skills for diagnosing components, assemblies and sub-assemblies to complete maintenance, installation, service and repair activities, in line with the requirements of the brief, working systematically, logically and efficiently.

Demonstrate exemplary technical skills using tools and equipment for control and instrumentation maintenance, installation and repair, ensuring safe isolation, removal and replacement of components, working systematically, logically and efficiently.

Demonstrate comprehensive knowledge and understanding of the principles and processes required for disassembly, repair, configuration and re-assembly of control and instrumentation systems, ensuring that all tolerances and calibrations are in-line with specification.

Work safely and make well founded and informed decisions on the selection and appropriate use of tools, materials and equipment within the working environments for maintenance, installation and repair activities.

Consistently and accurately use industry and technical terminology across different communication methods with full consideration of technical and non-technical audiences.

2. Assignment brief

You are a Control and Instrumentation Maintenance Engineer working on an oil and gas process rig.

Your supervisor has asked you to complete a planned maintenance activity on the temperature control system for one of the oil tanks. The system consists of a thermocouple connected through a transmitter head and monitored remotely through a wireless network. It has also been reported that the human machine interface (HMI) is indicating the system is offline, which you are required to investigate.

A block diagram, schematic diagram and specification detailing the temperature control system layout and expected operation are shown in Figures 1 and 2 below.

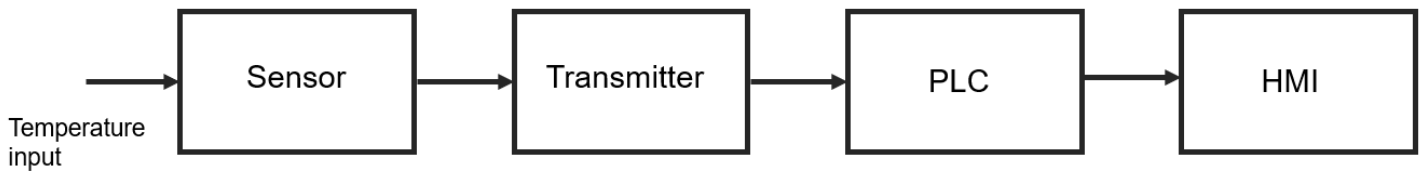

Figure 1 - Block diagram

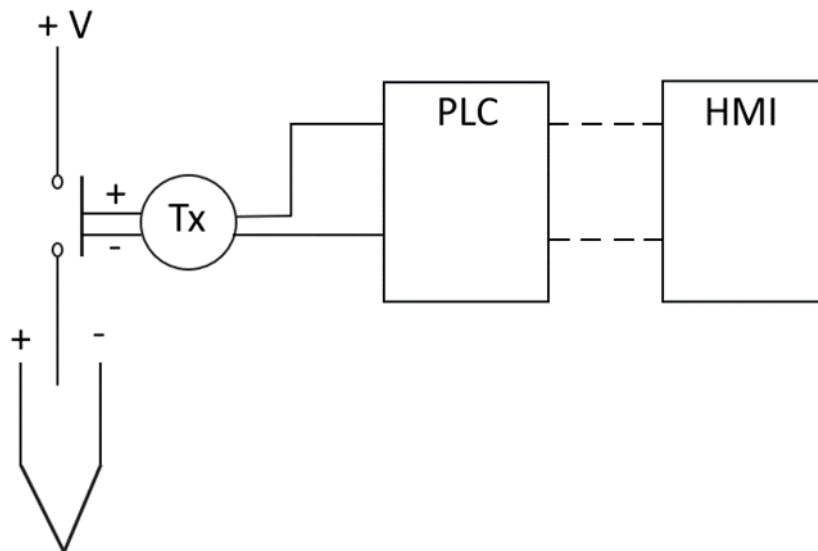

Figure 2 - Schematic diagram

Specification:

When in normal operation, the system should function as follows:

- the thermocouple is used to monitor the temperature of the oil in the tank
- the transmitter converts the temperature to a 4-20 mA signal and transmits the signal to the programmable logic controller (PLC)
- the PLC is programmed to maintain and monitor the temperature in the tank according to the set parameters

- the PLC is connected remotely to the HMI
- the HMI indicates when the temperature is outside the range of 40°C to 60°C and displays the current operational state of the process.

You must:

- plan the maintenance required
- perform the maintenance activities, including diagnosing any faults and performing subsequent repairs
- review and report the findings of the maintenance completed.

This assignment has a time allocation of **22 hours**.

3. Tasks

General task guidance

Please read **ALL** information carefully before the assessment.

Ensure you have read the following guidance before you undertake the assessment of candidates:

- T level technical qualifications – marking
- T level technical qualifications – moderation (updated annually)
- T level technical qualifications – teaching, learning and assessment
- Technical qualification guides on marking and moderation
- Practical Observation template
- Marking grids following the tasks below
- Feedback guidance for assessors.

All work carried out should be to industry standards, undertaken in a safe manner and compliant with relevant regulations. If a candidate fails to carry out the activities in a safe manner, the assignment should be suspended until this aspect is corrected. Further guidance for assessors can be found in the centre guidance section under health and safety.

Photographs must be used to support the qualitative statements captured on the Practical Observation form. Details of specific photograph requirements are outlined in the task information below. Photographs must have the date and candidate's name attached so that they can be differentiated. The candidate does not need to be in the photograph, the purpose of the photograph is to demonstrate the quality and standards of work of specific activities and of the work throughout various stages of the assignment.

Centres must provide candidates with access to an appropriate system to perform the maintenance activity. Although there can be some flexibility with regards to the components used, the overall system must meet the requirements given in the assignment brief. Centres must ensure machines are in full working order and only contain the faults defined by the task specific guidance, but do not need to be in perfect condition.

Time

The time allocated for the completion of the tasks and production of evidence for this assessment is 22 hours. Timings for completion of specific tasks are outlined below.

- Task 1 – 5 hours
- Task 2 – 11 hours
- Task 3 – 5 hours
- Task 4 – 1 hour.

When working under supervised conditions for longer sessions, breaks can be facilitated outside of the controlled conditions, ensuring the room is locked and all candidates have vacated once the break begins. All materials must be kept securely during the break.

Scheduling assessment sessions

It is the centre's responsibility to arrange how time is managed to fit with timetables and meet the times allocated for each task during the assessment window. Assessment windows are specified in the key date schedule.

The tasks must be issued in order, one at a time to candidates by centres in the scheduled assessment times. Candidates are able to refer to the brief and scenario during all of the scheduled assessment time. Candidates are not permitted to return to tasks after the assessment time for the task has ended and the next task has begun. Candidates must not move on to the next task within the assessment session until instructed to do so by the assessor. It is the assessor's responsibility to ensure that all evidence for a task has been submitted before administering the next task. Candidates are not required to have formal reading time for the scenario and brief, this is included within the duration for Task 1.

When working under supervised conditions for longer sessions, breaks can be facilitated outside of the controlled conditions, ensuring the room is locked and all candidates have vacated once the break begins. All materials must be kept securely during the break.

Centres should aim to schedule tasks in the fewest amount of assessment sessions but ensure that the durations dictated for each task are covered. However, to aid deliverability and manageability of assessment, sessions can be split where there is a requirement. For example, where timetabling of an appropriate location for six hours is not possible, e.g. where centre's access to computer resources is limited, or where candidates are not available for six consecutive hours (e.g. due to work placement commitments). Where this is necessary, sessions must be timetabled over consecutive days and in as few sessions as possible. All assessment evidence must be stored securely and access to assessment materials and their work only given to candidates during the formal assessment times. All candidates are required to complete a declaration of authenticity along with their evidence submission, and the arrangements must support the assessor in being confident in confirming authenticity.

Where assessments need to be completed in a number of assessment sessions or over consecutive days all practical work areas and any evidence produced must be kept secure and must only be accessed by the assessor. Information and notices should be used to inform other users of the facility that no access will be granted when assessment sessions are in progress. Practical work areas, tools, equipment and systems for the assessment must not be reset until a candidate has completed the full assessment.

Peer review

Within the Occupational Specialism assessment, candidates will be asked to carry out a peer review. Instructions for this are shared as part of the task within the assessor guidance. Candidates are not marked on the peer review they carry out but still need to submit this to the assessor. What needs to be submitted within this task will be covered by the 'what needs to be submitted' section.

Internet access

Where internet access is allowed as part of a task (e.g. for research purposes) candidates must be advised that this is the case and reminded of the importance of submitting their own work and the seriousness of plagiarism, malpractice and collusion. Candidates should be advised that their browser history can be monitored and checked. Depending on the type of task candidates may be requested to submit their internet search history to be considered as part of the submission of evidence, in order to confirm the authenticity of submitted evidence.

Where candidates are allowed the use of computer equipment, but not the use of the internet for a task, equipment should be provided with internet capability disabled (e.g. Wi-Fi disabled, machine disconnected from network etc).

Resources

Candidates must have access to a suitable range of resources to carry out the tasks and, where appropriate, to have the opportunity to choose components, tools and equipment that demonstrate their ability to select from a range of appropriate materials.

Where candidates need access to evidence that has been submitted as part of a previous task, this will be provided as a copy of the original evidence and will be given at the start of the relevant task.

The candidate should have access to the following to select and carry out each task:

- electrical supply to suit the needs of the system
- an appropriate temperature control system matching the requirements of the brief
- wireless network (Bluetooth or Wi-Fi)
- access to relevant information sources (digital or hard copy), including Figures 1 and 2, wiring diagrams, component datasheets, manufacturer's specification, manufacturer's recommended procedures, operation and maintenance manuals, technical manuals and circuit diagrams/schematics
- appropriate personal protective equipment (PPE)
- appropriate components to replace faulty items, including transmitters, potentiometers, and temperature sensors
- a range of materials and consumables to select from, including wiring, insulation, solder, connectors and fasteners, PPE
- a range of appropriate measurement, fault diagnosis, test and calibration equipment, including multimeters, diagnostic testers, temperature bath, multi-function calibrators and loop calibrator
- a range of relevant tools and equipment for maintenance and repair, including pliers, wire cutters, wire strippers, screwdrivers and potentiometer trimmer
- appropriate ICT equipment and software, including relevant PLC programming hardware and software.

Task specific guidance

Each task should be administered separately, and each task should be completed and submitted by all candidates before moving onto the next.

The system provided must meet the requirements detailed in the brief.

The system and circuitry provided must have **four** faults built into it for candidates to diagnose and repair. These must be as follows:

- remote monitoring system offline caused by wireless/network connection failure
- open circuit from the sensor
- failed transmitter potentiometer
- incorrect sensor type inputted into PLC program causing inaccurate outputs.

Note, for live assessment, a larger range of comparable faults will be indicated in this section of the guidance, from which four must be built into the system and circuitry for each candidate to diagnose and repair. Where there is the potential for candidates to be taking the practical tasks at different times, then the faults provided should be rotated to ensure that these candidates are presented with a different selection of faults to detect.

Resources are specified through centre resource list in advance of the assessment but will not be made available to students as this will lead students to know the faulty components. Candidates will have access to the workshop/tool cupboard to select resources rather than a list and the required resources are dictated by the guidance and brief.

Task 1

Candidates must be provided with all relevant technical documentation for the system they will be working on, including the current maintenance and service schedule. Where these documents are digital copies, they must be downloaded and saved for the candidates to access **without** the need to access the internet.

Resources

- access to relevant information sources (digital or hard copy), including Figures 1 and 2, wiring diagrams, component datasheets, manufacturer's specification, manufacturer's recommended procedures, operation and maintenance manuals, technical manuals and circuit diagrams/schematics
- an appropriate temperature control system and electrical supply to suit the needs of the system
- work area to complete risk assessment
- a range of appropriate measurement, fault diagnosis, test and calibration equipment to select from, including multimeters, diagnostic testers, temperature bath, multi-function calibrators and loop calibrator
- a range of relevant tools and equipment for maintenance, installation and repair to select from, including pliers, wire cutters, wire strippers, screwdrivers and potentiometer trimmer.
- a range of materials, components and consumables to select from, including PPE
- appropriate ICT equipment and software, including relevant PLC programming software.

Task 2

All relevant health and safety procedures, including safe isolation, must be observed at all times. If a candidate acts in a way that is likely to endanger themselves or others, the assessment must be stopped immediately.

Work area must be representative of normal centre practice prior to any practical activities taking place for candidates to complete their work area preparation.

Candidates must have access to the workshop/tool cupboard for any additional tools, equipment and components not previously selected in Task 1, which candidates are then able to annotate on their method statement with any changes to their original plans.

No one other than the candidate should interact with the system during the 11 hour period of Task 2.

As part of Task 2, candidates must carry out the return to service and demonstrate the system functionality with the assessor taking the part of the supervisor, which must take place on-site so the candidate is able to demonstrate the system functionality.

Resources

- copies of completed planning documentation from Task 1
- access to relevant information sources (digital or hard copy), including Figures 1 and 2, wiring diagrams, component datasheets, manufacturer's specification, manufacturer's recommended procedures, operation and maintenance manuals, technical manuals and circuit diagrams/schematics
- an appropriate temperature control system and electrical supply to suit the needs of the system
- working area
- appropriate PPE
- a range of materials and consumables
- a range of relevant tools and equipment for maintenance and repair
- a range of appropriate measurement, fault diagnosis, test and calibration equipment
- appropriate components to replace faulty items, including wiring and transmitters
- appropriate ICT equipment and software, including relevant PLC programming software.

Task 3a

Candidates are expected to write a technical report covering all aspects of the maintenance and repair activities and are guided with a typical word count of 850 words.

Resources

- copies of completed documentation from Tasks 1 and 2
- access to relevant information sources (digital or hard copy), including Figures 1 and 2, wiring diagrams, component datasheets, manufacturer's specification, manufacturer's recommended procedures, operation and maintenance manuals, technical manuals and circuit diagrams/schematics
- appropriate ICT equipment and software.

Task 3b

All candidates must complete a peer review task. A template to provide peer review feedback will be given to ensure a reliable and comparable level of feedback is obtained for each candidate.

Each candidate should carry out up to a maximum of two peer reviews on different revised maintenance schedules in order to provide feedback to the candidate for them to reflect on and respond to. In a separate session, each candidate should receive two completed peer review feedback forms that have been checked by the assessor for their revised maintenance schedule. The completed peer review feedback forms must be submitted to support marking. All candidates providing peer review feedback must be at the same stage in the assessment process as the candidate they are providing feedback to (i.e. they must have already completed the practical elements of Tasks 2 and 3a).

Resources

- copies of completed documentation from Tasks 1, 2 and 3a
- two completed peer review forms for each candidate
- access to relevant information sources (digital or hard copy), including Figures 1 and 2, wiring diagrams, component datasheets, manufacturer's specification, manufacturer's recommended procedures, operation and maintenance manuals, technical manuals and circuit diagrams/schematics
- appropriate ICT equipment and software.

Task 4

Candidates must carry out the handover procedures with the assessor taking the part of the supervisor. This is likely to be a desk-based activity given the system functionality was demonstrated at the end of Task 2. The assessor must not ask any questions or prompt the candidate at any point in this meeting. The meeting should be recorded on video for the assessor to refer back to when completing the Practical Observation form and submit as evidence. The video recording should be a maximum of 30 minutes.

Resources

- copies of completed documentation from Tasks 1, 2 and 3, including the two completed peer review forms
- access to relevant information sources (digital or hard copy), including Figures 1 and 2, wiring diagrams, component datasheets, manufacturer's specification, manufacturer's recommended procedures, operation and maintenance manuals, technical manuals and circuit diagrams/schematics
- the temperature control system maintained in Task 2 and electrical supply to suit the needs of the system to demonstrate system functionality, no further changes should be made to the system at this point.

Following tasks, copies of the final submitted evidence from preceding tasks should be saved securely for return to candidates for use in future tasks within this assessment. This could be facilitated through the use of memory sticks or a specific location on a secure drive for work to be saved on.

Task 1 – Plan and prepare for the maintenance activities

Candidates must analyse the brief and technical information about the system provided and then:

- a) create a list of the requirements and resources for the maintenance activities, justifying their selections. This should include:
 - all necessary technical information to confirm the type, scope and requirements of the activity
 - tools and equipment
 - materials, components and consumables
 - wastage and disposal requirements
 - time needed to carry out the activity
 - fault diagnosis methods to be used
 - any access requirements
- b) produce and complete a risk assessment
- c) produce a method statement.

Conditions of assessment:

- the time allocated for this task is **5 hours**
- candidates must carry out the task on their own, under **controlled conditions** while being observed.

Controlled conditions:

- candidates must only work on their tasks in the allocated times
- assessment evidence must be handed in at the end of each session for secure storage which cannot be accessed by candidates
- candidates must not share or discuss their work with other candidates
- candidates are not permitted to bring any materials into the assessment session.

What must be produced for marking:

- a list of requirements and resources, including justifications for the selections
- completed risk assessment
- method statement.

Resources:

- access to relevant information sources (digital or hard copy), including Figures 1 and 2
- an appropriate temperature control system and electrical supply to suit the needs of the system
- work area to complete risk assessment
- a range of appropriate measurement, fault diagnosis, test and calibration equipment to select from
- a range of relevant tools and equipment for maintenance, installation and repair to select from
- a range of materials, components and consumables to select from, including personal protective equipment (PPE)
- appropriate ICT equipment and software.

Task 2 – Perform the maintenance activities

Candidates must:

- a) prepare the work area for the maintenance activities
- b) perform the maintenance activities in accordance with the method statement and planning documents produced in Task 1. This should include:
 - decommissioning and inspection of the system
 - disassembly and reassembly of the system
 - diagnosing and recording faults within the system, including carrying out appropriate tests
 - repairing the faults and replacing components as required
 - safely using the appropriate tools and equipment
 - recommissioning of the system
 - demonstration of system functionality to the client
 - re-instating the work area
- c) record the maintenance activities, to include:
 - calibration results
 - completed test record sheets
 - updated maintenance records and control documents
 - annotated method statement, including any recommendations for further investigation if required.

Conditions of assessment:

- the time allocated for this task is **11 hours**
- candidates must carry out the task on their own, under **controlled conditions** while being observed
- candidates must be given copies of their completed documentation from Task 1
- correct PPE must be worn at all times and as designated in their risk assessment (if unsafe working occurs the assessment must be stopped immediately).

Controlled conditions:

- candidates must only work on their tasks in the allocated times
- assessment evidence must be handed in at the end of each session for secure storage which cannot be accessed by candidates
- where assessments need to be completed in a number of assessment sessions or over consecutive days all practical work areas and any evidence produced must be kept secure and must only be accessed by the assessor
- candidates must not share or discuss their work with other candidates
- candidates are not permitted to bring any materials into the assessment session
- assessor observations must be carried out within the assessor to candidate ratio stipulated by City & Guilds.

What must be produced for marking:

- calibration results
- completed test record sheets
- updated maintenance records and control documents

- annotated method statement, including any recommendations for further investigation if required.

Additional evidence for this task:

- assessor observations of the work area preparation
- assessor's observations of the maintenance activities
- assessor observation of system functionality demonstration.

To support the comments made within the Practical Observation the assessor must capture the following photographs that must be submitted as supporting evidence for each candidate.

Photographic evidence which shows:

- the prepared work area
- the working area after disassembly
- test set up for calibration
- top of the thermocouple to show the wiring of the replaced transmitter, including connections
- the re-instated work area.

Resources:

- copies of completed planning documentation from Task 1
- access to relevant information sources (digital or hard copy), including Figures 1 and 2
- an appropriate temperature control system and electrical supply to suit the needs of the system
- working area
- appropriate PPE
- a range of materials and consumables
- a range of relevant tools and equipment for maintenance and repair
- a range of appropriate measurement, fault diagnosis, test and calibration equipment
- appropriate components to replace faulty items
- appropriate ICT equipment and software.

Task 3a – Review and report the maintenance activities

Candidates must:

- i. produce a technical report for the supervisor. This should be typically 850 words and include:
 - a review of the maintenance activities, including fault diagnosis/detection techniques and suggestions for future improvements
 - the faults found and how they were rectified
 - any outstanding faults, including recommendations that may require attention before the next planned maintenance activity according to the current maintenance schedule
 - reporting of stock levels and waste disposal
- ii. produce a revised maintenance schedule from their activities and findings, this should include:
 - recommendations for future planned maintenance including justifications
 - due date of next maintenance activity.

Conditions of assessment:

- the time allocated for this task is **3 hours**
- candidates must carry out the task on their own, under **controlled conditions** while being observed
- candidates must be given copies of their completed documentation from Tasks 1 and 2.

Controlled conditions:

- candidates must only work on their tasks in the allocated times
- assessment evidence must be handed in at the end of each session for secure storage which cannot be accessed by candidates
- candidates must not share or discuss their work with other candidates
- candidates are not permitted to bring any materials into the assessment session.

What must be produced for marking:

- a technical report
- revised maintenance schedule, including justifications.

Resources:

- copies of completed documentation from Tasks 1 and 2
- access to relevant information sources (digital or hard copy), including Figures 1 and 2
- appropriate ICT equipment and software.

Task 3b – Peer review

The candidate's maintenance schedule will now be reviewed by two peers to provide the candidate with feedback. All candidates will also peer review two maintenance schedules. Assessors must distribute the maintenance schedules for candidates to review and provide peer review forms for candidates to complete the written feedback.

Candidates must:

- i. carry out a peer review on two maintenance schedules provided by the assessor.
Candidates must consider the following:
 - *how well does the schedule enable planned maintenance activities to be performed and recorded over time?*
 - *how appropriate are the recommended planned maintenance intervals and why?*
 - *what are the implications to the business of the proposed maintenance schedule?*
 - *how could the maintenance schedule be optimised/improved?*
- ii. write up feedback for each of the maintenance schedules on separate peer review forms
- iii. update their maintenance schedule following feedback from the peer review. Any updates need to include justifications for these changes and any changes not made will be reviewed in the handover.

Conditions of assessment:

- the time allocated for this task is **2 hours**:
 - i. 30 minutes to complete a review of two maintenance schedules
 - ii. 30 minutes to write up feedback on a peer review form for each maintenance schedule
 - iii. 1 hour to independently update their maintenance schedule justifying any changes made
- candidates must carry out the task on their own, under **controlled conditions** while being observed
- the peer reviewers will be providing written feedback using the peer review form provided by the assessor on any aspect of the maintenance schedule for the candidate to reflect on and respond to.

Controlled conditions:

- candidates must only work on their tasks in the allocated times
- assessment evidence must be handed in at the end of each session for secure storage which cannot be accessed by candidates
- candidates must not share or discuss their work with other candidates
- candidates are not permitted to bring any materials into the assessment session.

For parts i) and ii) **peer reviewers** must:

- manage their time effectively
- respond constructively and fairly
- ensure the feedback review form is completed fully and handed to the assessor.

For part iii) **candidates** must:

- reflect on and respond to the feedback provided on the peer review feedback form to update their maintenance schedule.

For parts i) to iii) **assessors** must:

- familiarise themselves with the task specific guidance section to support the administration of the peer review task
- provide clear instructions on the purpose and conditions of the task
- can intervene at their discretion if they believe there is a risk of the candidate not receiving sufficient feedback. In this context, it means there is sufficient feedback being given and recorded on the peer review form, it aligns with the task and is realistic and meaningful for the candidate to use to inform the maintenance schedule
- ensure all candidates receive a completed peer review feedback form and the quality of feedback is sufficient before handing it to the candidate
- ensure the completed peer review forms are submitted as evidence to support marking.

What must be submitted:

- completed peer review forms.

What must be produced for marking:

- maintenance schedule amended from peer review feedback, including justifications.

Resources:

- copies of completed documentation from Tasks 1, 2 and 3a
- two completed peer review forms
- access to relevant information sources (digital or hard copy), including Figures 1 and 2
- appropriate ICT equipment and software.

Task 4 – Complete handover

Candidates must now hold a meeting with the supervisor to complete handover procedures, including:

- confirmation of work completed
- amended maintenance schedule and how they addressed peer review feedback, including any suggested changes that were not made and why
- appropriate handover documentation.

Conditions of assessment:

- the time allocated for this task is **1 hour**
 - 30 minutes to prepare for the handover meeting and 30 minutes to carry out the handover meeting
- candidates must carry out the task on their own, under **controlled conditions** while being observed
- candidates must be given access to their completed documentation from Tasks 1, 2 and 3
- candidates must carry out the handover meeting, with the assessor taking the part of the supervisor
- there will be no interaction required or permitted as part of the handover.

Controlled conditions:

- candidates must only work on their tasks in the allocated times
- assessment evidence must be handed in at the end of each session for secure storage which cannot be accessed by candidates
- where assessments need to be completed in a number of assessment sessions or over consecutive days all practical work areas and any evidence produced must be kept secure and must only be accessed by the assessor
- candidates must not share or discuss their work with other candidates
- candidates are not permitted to bring any materials into the assessment session.

What must be produced for marking:

- handover documentation.

Additional evidence for this task:

- assessor observations of the handover meeting.

To support the comments made within the Practical Observation the assessor must capture the following video that must be submitted as supporting evidence for each candidate.

Video evidence which shows:

- handover meeting with the supervisor, maximum of 30 minutes.

Resources:

- copies of completed documentation from Tasks 1, 2 and 3, including the two completed peer review forms
- access to relevant information sources (digital or hard copy), including Figures 1 and 2

- appropriate ICT equipment and software.

4. Centre guidance

Guidance provided in this document supports the administration of this project.

The following documents, available on the City & Guilds website, provide essential generic guidance for centres delivering Technical qualifications and **must** be referred to alongside this guidance:

- ***T level technical qualifications – marking***
- ***T level technical qualifications – moderation*** (updated annually)
- ***T level technical qualifications – teaching, learning and assessment.***

This assessment is designed to require the candidate to make use of their Core knowledge, understanding and the practical skills they have built up over the course of their learning to tackle tasks/problems/challenges.

This approach to assessment emphasises to candidates the importance and applicability of the full range of their learning to practice in their industry area and supports them in learning to take responsibility for transferring their knowledge, understanding and skills to the practical situation, fostering independence, autonomy and confidence.

Candidates are provided with an assignment brief. They then have to draw on their knowledge and skills and independently select the correct processes, tools, equipment, materials and approaches to take, to complete the brief.

During the learning programme, it is expected that tutors will have taken the opportunity to set shorter, formative tasks that allow candidates to be supported to independently use the learning they have so far covered, drawing this together in a similar way, so they are familiar with the format, conditions and expectations of the assessment.

Candidates should be made aware during learning what the assessment themes are and how they are implemented in marking the assignment, so they will understand the level of performance that will achieve them high marks.

Candidates should **not** be entered for the assessment until the end of the course of learning for the qualification, so they are in a position to complete the assignment successfully.

Health and safety

Candidates must not be entered for assessment without being clear of the importance of working safely and having attended sufficient practical training to be able to work safely. The assessor must immediately stop an assessment if a candidate works unsafely. At the discretion of the assessor, depending on the severity of the incident, the candidate may be given a warning. If they continue to work unsafely, risking the safety of themselves or others however, their assessment must be ended, and they must retake the assessment in a future series after significant further training has taken place. Any warnings issued to a candidate must be considered as part of the marking process and recorded on the candidate record form (CRF). Any actions that have led to that warning must be detailed on the CRF so they can be considered along with the other evidence when applying the descriptors in the mark scheme.

Compliance with timings

Due to the nature of this assessment, the maximum time allowances provided must be adhered to. They refer directly to assessment time, not any additional setting up times the centre needs to create an appropriate assessment environment.

It is the centre's responsibility to plan sufficient assessment sessions as stated in each of the tasks, under the appropriate conditions, within the assignment window, to allow candidates reasonable time to complete the assessment tasks.

Where candidates are required to plan their work, they should have their plans confirmed for appropriateness in relation to the time allocated for each task, to ensure their planning has not left them with too short a time to complete the tasks safely. Any planning that is not appropriate must be recorded on the candidate record form (CRF) as part of the marking process.

Candidates should be allowed sufficient time to fully demonstrate the range of their skills, however this also needs to be reasonable and practicable. Candidates should be allowed to overrun their own planned timings in order for evidence of a range of their skills to be captured. If, however, the time required exceeds the maximum time allowance for the task, the centre must stop the assessment and base the marking on the evidence up to that point.

Any guidance or feedback relating to timings/planning should follow the guidance provided in section *Guidance and feedback* below.

Word counts

Typical word counts, where indicated, are to be used as approximates for guidance to support the production of sufficient evidence. The marking will relate to the quality of the evidence produced and not whether the word count has been met.

Assessor student ratios

The number of candidates an assessor will be able to observe at one time will vary depending on local conditions relating to:

- monitoring and maintaining safety during assessment
 - any specific hazards related to the task that pose a risk of harm in relation to the competence of the learners
 - availability of supervisory staff to support the assessor
- the practicalities of collecting evidence
 - the complexity of evidence collection for the task
 - whether there are any peak times where there is a lot of evidence to collect that will need additional support or any that are quieter which may be eased through staggered starts etc
 - local conditions e.g.
 - layout of the assessment environment and sufficient assessor line of sight to task activity throughout the assessment period
 - amount of additional support available (e.g. to capture image/video evidence)
 - availability of suitable workspaces/bays or of shared resources and equipment.

Centres are advised to trial the planned arrangements during formative assessment, reviewing the quality of evidence captured and manageability.

It is expected that for straightforward observations, with favourable local conditions and support, (and unless otherwise specified) no more than three candidates will be observed by a single assessor at one time.

The key factors to consider are the logistics of collecting sufficient evidence and ability to remain working safely in the assessment environment. A timetable of assessments and layout of the workspaces, detailing:

- the students being assessed at each workstation,
- the assessor(s) and

- support staff present
- must be available for the moderator on request.

Observation evidence

Observation notes form part of the candidate's evidence and must capture evidence of student performance during the practical tasks describing how well the activity has been carried out, rather than stating the steps/actions, the candidate has taken. The notes must be very descriptive and focus on the quality of the performance that are notable in relation to the quality indicators in the marking grid. They must provide sufficient, appropriate evidence that can be used by the assessor (and moderator) to mark the performance using the marking grid. These descriptions will be used, along with e.g. photographic and video evidence to choose the relevant marking band and mark within the band so that students can be reliably and validly differentiated based on their performance. Evidence captured in the observation form must give the necessary information to enable the final assessment of the task at a later date. This is to allow a holistic judgement to be carried out after all evidence for the task is available, at which point full consideration of how the student has applied both their skills and their knowledge during the practical can be given.

Identifying what it is about the performances that is different between candidates can clarify the qualities that are important to record. Each candidate is likely to carry out the same steps, so a checklist of this information would not help differentiate between them. However, qualitative comments on how well they do it, and quantitative records of accuracy and tolerances would.

The assessor should refer to the marking grid to ensure appropriate aspects of performance are recorded. These notes will be used for marking and moderation purposes and so must be detailed, accurate and differentiating.

Assessors should refer to the **Technical qualifications guides on marking and moderation** and The Guide Standard Exemplification Materials to support with the collection of evidence through observation.

Assessors should ensure that any required additional supporting evidence including e.g. photographs or video can be easily matched to the correct candidate, are clear, well-lit and showing the areas of particular interest in sufficient detail and clarity for assessment (i.e. taken at appropriate points in production, showing accuracy of measurements where appropriate).

Assessor marking and justification is completed on a separate form (CRF) to differentiate this evidence from the judgement, since in some cases the observation form will provide evidence relating to the judgement for more than one assessment theme.

As far as possible, candidates must not be distracted, or their performance affected by the process of observation and evidence collection.

The **Technical qualifications guides on marking and moderation** are essential guidance documents and are available on the City & Guilds website. These provide further information on preparing for assessment, evidence gathering, standardisation, marking and moderation, and must be referred to when planning and carrying out assessment.

Video and photograph evidence in T Level Technical qualifications

The assessment materials for each assignment identify the minimum candidate and assessor evidence requirements to support marking and moderation. Where ephemeral evidence (e.g. areas of candidate performance that may be hard to capture with photographs and assessor notes alone) plays a significant part of the practical assessment. If this is the case City & Guilds will prescribe the type/capture where the use of video is necessary for practical assessment components (e.g. specifying exactly which elements of the practical must be videoed, or photographed), and any technical specifications for these forms of evidence e.g. length of videos, maximum file sizes etc will also be supplied. Photographic and video evidence will be submitted along with the written candidate evidence and assessor evidence (PO forms) as described in the additional evidence section of the task.

If this is the case then the video evidence must meet these minimum requirements, in order to be considered by moderators:

- as per the guidance in section 2.3.2 of *The Marking and Moderation Guide for Centres*, assessors must ensure that this evidence can be easily matched to the correct candidate and task, is clearly shot, well-lit and shows the areas of particular interest in sufficient detail and clarity for assessment (i.e. filmed at appropriate points in production, showing accuracy of measurements where appropriate)
- the qualitative written evidence provided by assessors must:
 - clearly identify the parts of the video that are being referred to, when used as supporting evidence. Using a timecode for this is recommended
 - include their judgement on the performance being demonstrated
- Section 6.5 of the *Centre Manual* also contains general information about the requirements for video evidence submission.

Please note that centres must ensure that video evidence is clear and meets the minimum requirements. The ability of the moderators to take this evidence into account may be impaired and delay the moderation process if the requirements are not met.

Minimum evidence requirements for marking and moderation

The sections in the assignment:

- ***What must be produced for marking***, and
- ***Additional evidence for this task***.

These list the minimum requirements of evidence to be submitted for marking and the moderation sample.

Evidence produced during assessment above and beyond this may be submitted, as long as it provides useful information for marking and moderation and has been produced under appropriate conditions.

While technological methods which support the capturing or creating of evidence can be helpful, e.g. pin board style websites for creating mood boards, the final evidence must be converted to a suitable format for marking and moderation which cannot be lost/ deleted or amended after the end of the assessment period (e.g. screen prints, pdf files). Considerations around tracking authenticity and potential loss of material hosted on such platforms during assessment is the centre's responsibility.

Note: Combining candidates' individual pieces of evidence into single files or zip files may make evidence management during internal marking more efficient and will greatly simplify the uploading of the moderation sample.

Where the minimum requirements have not been submitted for the moderation sample by the final moderation deadline, or the quality of evidence is insufficient to make a judgement, the moderation, and therefore any subsequent adjustment, will be based on the evidence that *has* been submitted. **Where this is insufficient to provide a mark on moderation, a mark of zero must be given.**

Preparation of candidates

Candidates should be aware of which aspects of their performance will give them good marks in assessment. This is best carried out through routinely pointing out good or poor performance during the learning period, and through formative assessment. Although candidates will not have access to the marking grids during the assessment. Candidates should be made aware of what

they need to do to achieve a pass or distinction by referring and formatively being assessed against grade descriptors as part of their formal learning programme.

During the learning programme, direct tutor instruction in how to approach tasks through modelling, support, guidance and feedback are critical. However, gradual removal of this support is necessary in preparation for summative assessment. This supported approach is not valid for summative assessment.

The purpose of summative assessment is to confirm the standard the candidate has reached as a result of participating in the learning process. Candidates should be encouraged to do the best they can and be made aware of the difference between these summative assessments and any formative assessments they have been subject to. Candidates will not have access to the marking grids. Refer to the ***T Level Technical qualifications – teaching, learning and assessment*** centre guidance document, available on the City & Guilds website for further information on preparing candidates for Technical qualification assessment.

Guidance on assessment conditions

The assessment conditions that are in place for this assignment are to:

- ensure the rigour of the assessment process
- provide fairness for candidates
- give confidence in the outcome.

They can be thought of as the rules that ensure that all candidates who take an assessment are being treated fairly, equally and in a manner that ensures their result reflects their true ability.

The conditions outlined below relate to this assignment. These do not affect any formative assessment work that takes place, although it is advised that candidates are prepared for the conditions they will need to work under during summative assessment.

The evidence for the tasks that make up this assignment must be completed under the specified conditions. This is to ensure authenticity and prevent malpractice as well as to assess and record candidate performance for assessment in the practical tasks. It is the centre's responsibility to ensure that local administration and oversight gives the assessor sufficient confidence to be able to confirm the authenticity of the candidate's work.

Security and authentication of candidate work

Candidate evidence must be kept secure to prevent unsupervised access by the candidate or others. Where evidence is produced over a number of sessions, the assessor must ensure learners and others cannot access the evidence without supervision. This might include storing written work or artefacts in locked cupboards, restricting the use of systems to anyone but the candidate until system functionality is demonstrated, and collecting memory sticks of evidence produced electronically at the end of each session.

Candidates are required to sign declarations of authenticity, as is the assessor. The relevant form is included in this assignment pack and must be signed after the production of all evidence.

Where the candidate or assessor is unable to or does not confirm authenticity through signing the declaration form, the work will not be accepted at moderation and a mark of zero will be given. If any question of authenticity arises e.g. at moderation, the centre may be contacted for justification of authentication.

Accessibility and fairness

Where a candidate has special requirements, assessors should refer to the *Access arrangements and reasonable adjustments* section of the City & Guilds website.

Assessors can support access where necessary by providing clarification to any candidate on the requirements or timings of any aspect of this assignment. Assessors should not provide more

guidance than the candidate needs as this may impact on the candidate's grade, see the guidance and feedback section below.

All candidates must be provided with an environment, time frame and resources that allows them reasonable access to the full range of marks available.

Where candidates have worked in groups to complete one or more tasks for this assessment, the assessor must ensure that no candidate is disadvantaged as a result of the performance of any other team member. If a team member is distracting or preventing another team member from fully demonstrating their skills or knowledge, the assessor must intervene.

Guidance and feedback

To support centre file management, assessors may specify a suitable file format and referencing format for evidence (unless otherwise specified e.g. if file naming is an assessment point for the assignment). Guidance must only support access to the assignment brief and must not provide feedback for improvement. The level and frequency of clarification and guidance must be:

- recorded fully on the candidate record form (CRF)
- taken into account along with the candidate's final evidence during marking
- made available for moderation.

Assessors must not provide feedback on the quality of the performance or how the quality of evidence can be improved. This would be classed as malpractice. However, this does not apply if the assessor asks questions as part of the assessment process. Such requirements will be specifically stated within task centre guidance.

Assessors should however provide general reminders to candidates throughout the assessment period to check their work thoroughly before submitting it, and to be sure that they are happy with their final evidence as it may not be worked on further after submission.

Candidates can rework any evidence that has been produced for each task during the time allowed.

Assessors should check and be aware of the candidates' plans and designs to ensure management of time and resources is appropriate, and so any allowed intervention can take place at an appropriate time.

The information on the guidance given and captured on the CRF is part of the evidence that must be taken into account along with the other evidence for the task when marking. It is up to the assessor to decide if the guidance the candidate has required suggests they are lacking in any performance outcome and consider the severity of the issue when applying the marking criteria. The assessor must record where and how guidance has had an impact on the marks given, so this is available should queries arise at moderation or appeal.

What is, and is not, an appropriate level of guidance

- The assessor should intervene with caution if a candidate has taken a course of action that will result in them not being able to submit the full range of evidence for assessment. However, this should only take place once the assessor has prompted the candidate to check that they have covered all the requirements. Where the assessor has to be explicit as to what the issue is, this is likely to demonstrate a lack of understanding on the part of the candidate rather than a simple error, and full details should be recorded on the CRF.
- The assessor should not provide guidance if the candidate is thought to be able to correct the issue without it, and a prompt would suffice. In other words, only the minimum support the candidate actually needs should be given, since the more assessor guidance provided, the less of the candidate's own performance is being demonstrated and therefore the larger the impact on the marks awarded.

- The assessor must not provide guidance that the candidate's work is not at the required standard or how to improve their work. In this way, candidates are given the chance to identify and correct any errors on their own, providing valid evidence of knowledge and skills that will be credited during marking.
- The assessor must not produce any templates, pro-formas, work logs etc. If templates are provided by the awarding organisation as part of the assignment, these should not be adapted but can be provided to candidates either electronically or as paper based. Compliance of this requirement will be checked at moderation.

All specific prompts and details of the nature of any further guidance must be recorded on the relevant form and reviewed during marking and moderation.

5. Marking

Guidance on marking

Please refer to the *T Level Technical qualifications – marking and moderation* centre guidance documents for further information on gathering evidence suitable for marking and moderation, and on using the marking grid and forms.

The Candidate Record Form (CRF) is used to record:

- details of any guidance or the level of prompting the candidate has received during the assessment period
- rough notes bringing together relevant evidence from across tasks during marking
- summary justifications when holistically coming to an overall judgement of the mark for each performance objective and overall
- if an assessment has to be stopped on the grounds of Health and Safety or if a candidate has been working in an unsafe manner.

The Practical Observation form (PO) is used to record:

- descriptive information and evidence of candidate performance during an observation.

Carrying out marking using assessment themes

The process of marking each assessment theme is iterative and should follow the process below which will become more spontaneous over time as the descriptors become familiar. It is recommended to refer back to these frequently however, so the standard does not unintentionally drift over the marking period.

The indicative content gives an indication of the expected content parameters the responses are likely to cover, and which aspects of the evidence are relevant. It is not exhaustive, and an acceptable answer may concentrate more on depth rather than fully cover the range indicated or deviate into relevant topics not listed.

The specific task evidence listed within the assessor guide and marking grid must be used to make a judgement on performance in relation the specific assessment theme.

The assessment tasks guide the production of valid evidence under appropriate conditions for assessment. Candidate evidence from a range of tasks may contribute to the marking of a single assessment theme, or from a single task to more than one assessment theme. In this case different aspects of the evidence are being considered for each theme and need to be judged against the marking descriptors specified in the assessment themes independently of each other.

In some cases, the quality indicators looked for in the judgement may naturally be more strongly evidenced in one piece of evidence than another. For instance, more formulaic/prescriptive forms of evidence may not be able to generate evidence of higher levels of performance, so this evidence would need to be looked for in the other forms of evidence. This means that where a range of evidence is to be assessed, it should be treated as a single package of evidence for the purposes of marking even if generated through different tasks.

Timing of marking

As some assessment themes require the triangulation of a number of pieces of evidence, marking cannot take place until after all of these are available. This does not however mean that all marking needs to take place after all candidates have completed the whole assessment.

Also, it is possible to begin recording the notes that will justify the marking for some assessment themes as evidence is produced, with the final mark only being decided once the complete array of

evidence is available. This is particularly the case if later evidence is more confirmatory, and the earlier evidence is sufficiently informative for the qualities being assessed to make this a useful exercise.

Through planning, it should be possible to identify any evidence that can start being reviewed earlier, and the assessment themes which could be scheduled for earlier completion of marking e.g. while observation evidence is fresh in the mind should this be helpful. Care must of course be taken to ensure any evidence required by candidates to progress with another task are available for that task to take place. In addition, a sense check must take place across marking for each assessment theme, and across assessors, at the end to ensure marking has not drifted during the period. This may take the form of comparing candidate work to check that the ranking of quality of evidence matches the ranking of marks – where there are discrepancies marking should be checked for accuracy. These checks should be the responsibility of the Internal Quality Assurer and undertaken as part of the centre's Internal Quality Assurance strategy.

Process for each assessment theme:

- Select the range of evidence relevant for making the judgement – this is indicated in the mark scheme for each assessment theme. However, should relevant evidence for any candidate be found elsewhere amongst the rest of their evidence, this may also be taken into consideration when making the marking judgement as long as it is:
 - valid in relation to the assessment theme
 - is produced under appropriate conditions
 - and the marker is confident that it is authentic.
- Scan/read the candidate evidence, any notes on the CRF e.g. regarding level of support/guidance recorded, evidence captured by the assessor and the indicative content and band descriptors in the mark scheme.
- Note: for any warnings given during the assessment, the actions that have led to that warning must be detailed on the CRF so they can be considered along with the other evidence when applying the descriptors in the mark scheme.
- Note: the evidence contained on the CRF must be considered and a judgement made on the level of performance the candidate has independently demonstrated – this will vary depending on the level of support detailed on the CRF – i.e. consider all relevant evidence and then judge the appropriate mark following the process below.
- Make an initial assessment of the required evidence as a whole, considering each band in turn and considering the level of performance described in the context of the knowledge and skills in the indicative content to make a balanced judgement of the best band to use as a starting point.
- Read the evidence and review it against the band descriptor in more detail, deciding if the response is securely sitting within the band; i.e. all quality characteristics described by the band descriptor are seen, and strongly meets the level of performance described by the descriptor holistically (i.e. across the range of relevant evidence):
 - check the descriptor for the level above
 - if the evidence clearly shows some of the characteristics of the higher band, select a suitable mark at the bottom of that band
 - if *not* showing characteristics of the higher band revert to the original band, select a mark at the higher end of that mark range.

If the response is not securely in the band, but *is partially* showing the characteristics of the band,

- check the descriptor of the level below
- decide on a suitable mark either at the bottom of the original band as some characteristics shown, or top of the lower band if it better describes the quality of the characteristics being shown.

If the response is largely meeting the band, with only a few concerns, and is not showing characteristics aligning with the higher or lower bands, the appropriate mark is likely to be in the middle range.

If there is no alignment with the descriptor, reassess the starting band, and begin again.

- Based on the level of alignment with the descriptor, confirm the final mark within the band, bearing in mind that the available marks form an *evenly distributed scale*:
 - if the quality of response *fully* aligns with the performance described by the descriptor – assign a high mark within the band
 - if the quality of the response *partially* aligns with the performance described by the descriptor – assign a low to medium mark within the band
 - consider the quality compared to a range of similar responses (e.g. relevant annotated training material exemplars, responses reviewed during standardisation, and through experience) choose a mark on the point on the scale that would give an appropriate ranking for the assessed piece of evidence in relation to this information and in comparison with that of the rest of the cohort for that assessment theme.

Marking grid

There is a marking grid for each assessment theme that must be assessed as part of this Occupational Specialism assignment. The individual statements within the band descriptors should be treated together to make one whole descriptor and not separately.

Assessment theme - Health and safety

Guidance for assessors

Evidence from Tasks 1, 2, 3a and 4 should be used to assess performance against this assessment theme.

Task 1

- a list of requirements and resources, including justification for the selection
- completed risk assessment
- method statement.

Task 2

- updated maintenance records and control documents
- annotated method statement, including any recommendations for further investigation if required
- assessor observations of the work area preparation
- assessor observations of the maintenance activities
- photographic evidence of:
 - the prepared work area
 - the working area after disassembly.

Task 3a

- technical report.

Task 4

- assessor observations of handover meeting
- video evidence showing the handover meeting with the supervisor.

<p>Note: where there is insufficient evidence to award a mark, a zero mark must be given</p>	<p>Band 1 descriptor</p>	<p>Band 2 descriptor</p>	<p>Band 3 descriptor</p>	<p>Total marks per sub assessment theme</p>	<p>Total marks per assessment theme</p>
<p>Indicative content: Identification of risks and hazards that if not controlled could cause injury to themselves or others, that may include:</p> <ul style="list-style-type: none"> • low risk - slips, trips and falls, cuts and abrasions, irritants • medium risk - burns and scalding • high risk - stored energy, electrocution and malfunction. <p>Analysis of risk with appropriate mitigation and control measures prepared against hazards for planned tasks, including PPE. Assessment of risk as part of planning and preparing for maintenance and repair activities, including health and safety related preparatory checks on tools, equipment and the work area. Safe isolation procedures completed accurately and safely (Failure to complete all steps of safe isolation as specified below leading to an unsafe situation the assessment will be stopped immediately):</p> <ul style="list-style-type: none"> • obtain permission to start work • prove that the approved voltage indicator is functioning correctly • identify the source(s) of supply using an approved voltage indicator • isolate the supply and lock out tag out (LOTO) • prove the system/equipment is DEAD using an approved voltage indicator • put up warning signs to tell other people that the electrical installation has been isolated • once the system/equipment is proved DEAD, work can begin. <p>Safe working practices applied throughout inspection and testing, disassembly, reassembly, replacement and modification of components, sub-assemblies and systems, including:</p> <ul style="list-style-type: none"> • work area to be kept tidy throughout the tasks, and left in safe condition once completed, returning tools and equipment to correct storage facilities • wears the correct PPE at all times, as identified in their risk assessment and/or list of requirements and resources, including anti-static clothing, safety glasses, workwear and boots (correct PPE must be worn at all times. If unsafe working occurs the assessment is to be stopped immediately) 					

	<ul style="list-style-type: none"> following health and safety regulations, legal requirements and procedures (components, stored energy, safe removal). Technical report acknowledges the application of health and safety procedures throughout practical activities, evaluating the effectiveness of planned control measures and suggest improvements to future health and safety planning. 				
Marks per band	1-4	5-8	9-12	N/A	12
	<p>Risk assessment covers the majority of risk factors and some control measures have been identified. Likelihood or severity has been considered for some risks and hazards.</p> <p>Some relevant potential safety issues considered as part of preparatory checks and planning activities, including all steps of safe isolation procedures.</p> <p>Works safely during all practical activities, following all relevant safety procedures, but when working some low risk hazards were missed that did not result in any accident or injury.</p> <p>Work area left in safe condition, some tools and equipment not returned to correct storage facilities, disposal of waste was</p>	<p>Risk assessment covers a good range of risk factors, including risk control measures identified for most of the potential risks and hazards. Likelihood and severity has been considered for most risks and hazards.</p> <p>Most relevant potential safety issues considered as part of preparatory checks and planning activities, including all steps of safe isolation procedures.</p> <p>Works safely during all practical activities, following all relevant safety procedures, with most risks and hazards that occur during the tasks correctly mitigated against as they arise.</p> <p>Work area left safe, clean and tidy, with most tools and equipment returned to correct storage facilities, disposal of</p>	<p>Risk assessment is detailed and clearly identifies all of the associated risk factors, risk control measures and have been clearly identified for all potential risks and hazards. Likelihood and severity has been considered for all risks and hazards.</p> <p>All relevant potential safety issues fully considered as part of preparatory checks and planning activities, including all steps of safe isolation procedures.</p> <p>Works safely during all practical activities, following all relevant safety procedures, with all risks and hazards that occur during the tasks correctly prepared for and mitigated against as they arise.</p> <p>Work area returned to original condition with all tools and equipment returned to correct storage facilities,</p>		

	<p>carried out but with limited reference to disposal requirements and waste regulations.</p> <p>Minimal health and safety considerations have been included as part of reviewing, reporting or handover.</p>	<p>waste was carried out with some reference to disposal requirements and waste regulations.</p> <p>A good range of health and safety considerations have been included as part of reviewing, reporting and handover.</p>	<p>disposal of waste was carried out taking into account all of the disposal requirements and waste regulations.</p> <p>A comprehensive range of health and safety considerations have been included as part of reviewing, reporting and handover.</p>		
--	---	---	--	--	--

Assessment theme – Planning and preparation

Guidance for assessors

Evidence from Tasks 1 and 2 should be used to assess performance against this assessment theme.

Task 1

- a list of requirements and resources, including justification for the selection
- method statement.

Task 2

- assessor observations of the work area preparation
- photographic evidence of the prepared work area.

Note: where there is insufficient evidence to award a mark, a zero mark must be given	Band 1 descriptor	Band 2 descriptor	Band 3 descriptor	Total marks per sub assessment theme	Total marks for assessment theme
	<p>Indicative content: Planning:</p> <ul style="list-style-type: none"> • technical documentation relevant to the system gathered, prepared and analysed, including manufacturer’s specifications, operation manuals, maintenance schedule and records, and control and instrumentation representations to plan and prepare for maintenance activities • detailed method statement of how the task will be carried out in a logical manner with justifications and reasoning to support methods given using correct technical terminology • list of the appropriate requirements and resources for the system provided, including tools and equipment, materials, components and consumables, wastage and disposal requirements, time needed to carry out the activity, fault diagnosis methods to be used and any access requirements <ul style="list-style-type: none"> ○ components – transmitters, potentiometers, temperature sensors, thermocouples 				

	<ul style="list-style-type: none"> ○ tools and equipment – drivers, spanners, pliers, wire cutters, wire strippers, potentiometer trimmer, temperature bath, test and calibration equipment, multimeters, diagnostic testers, temperature bath, multi-function calibrators and loop calibrator ○ materials and consumables – wiring, insulation, solder, connectors and fasteners, PPE. <p>Preparation:</p> <ul style="list-style-type: none"> • appropriate materials, components and resources selected and prepared for the system, type and scope of the tasks, serviceability and working condition to complete the tasks in a timely manner • preparatory checks completed for tools and equipment (including calibration), obtaining permits to work, isolation requirements, work area, sensory, specifications, test dates (PAT test, calibration, electrical safety) • work area prepared logically in accordance with SOPs, with list of resources and requirements, calibrated tools and equipment on hand, manufacturer’s specifications and workplace requirements. 				
Marks per band	1-3	4-6	7-9	9	18
Planning	<p>Limited analysis of some technical documentation relevant to the system, covering some factors appropriate to the brief in limited detail.</p> <p>Method statement shows some consideration of scope, processes, tools and equipment, but may not be in a logical sequence or difficult to follow, using some relevant technical terminology but not always accurately.</p> <p>Limited list of resources and requirements, including relevant technical documentation, with limited justifications.</p>	<p>Analysis of most technical documentation relevant to the system, covering most factors appropriate to the brief in some detail.</p> <p>Method statement shows clear consideration of scope, processes, tools and equipment, which is mostly in a logical order and can be followed, using some relevant technical terminology accurately.</p> <p>Most resources and requirements are listed, including technical documentation, with some</p>	<p>Thorough analysis of all technical documentation relevant to the system, covering all factors appropriate to the brief in comprehensive detail.</p> <p>Method statement shows full consideration of scope, processes, tools and equipment, which is fully logical and can be easily followed by a third party, using relevant and accurate technical terminology throughout.</p> <p>Comprehensive list of all resources and requirements, including technical documentation, with full justifications for all.</p>		

		justifications for most, or full justifications for some.			
Marks per band	1-3	4-6	7-9	9	
Preparation	<p>Limited range of materials, components and resources selected with some consideration of working condition, serviceability, or feasibility.</p> <p>Minimal consideration for the condition, quality and performance of tools and equipment through completing limited preparatory checks.</p> <p>Work area prepared with some consideration of the prepared method statement and workflow, with calibration checks completed on limited tools and equipment.</p>	<p>A good range of materials, components and resources selected with some evaluation of working condition, serviceability and feasibility.</p> <p>Clear consideration for the condition, quality and performance of tools and equipment through completing a good range of preparatory checks.</p> <p>Work area prepared with clear consideration of the prepared method statement and workflow, with completed calibration checks on most selected tools and equipment.</p>	<p>A comprehensive range of materials, components and resources selected with detailed evaluation of working condition, serviceability and feasibility.</p> <p>Thorough consideration for the condition, quality and performance of tools and equipment through completing a comprehensive range of preparatory checks.</p> <p>Work area prepared with thorough consideration of the prepared method statement and workflow, with calibration checks completed on all selected tools and equipment.</p>		

Assessment theme – Systems and components

Guidance for assessors

Evidence from Tasks 1, 2, and 3a should be used to assess performance against this assessment theme.

Task 1

- a list of requirements and resources, including justification for the selection
- method statement.

Task 2

- calibration results
- completed test record sheets
- updated maintenance records and control documents
- annotated method statement, including any recommendations for further investigation if required
- assessor observations of the maintenance activities
- assessor observation of the work area preparation
- assessor observation of system functionality demonstration
- photographic evidence of:
 - test set up for calibration
 - top of the thermocouple to show the wiring of the replaced transmitter, including connections.

Task 3a

- a technical report.

Note: where there is insufficient evidence to award a mark, a zero mark must be given	Band 1 descriptor	Band 2 descriptor	Band 3 descriptor	Total marks per sub assessment theme	Total marks for assessment theme
--	--------------------------	--------------------------	--------------------------	---	---

Indicative content:

Inspection and testing:

- a variety of inspection and testing methods applied to the system:
 - functional testing – measurement of parameters, full system functionality, PLC program testing
 - sensory inspection – visual, auditory, touch, smell
 - loop testing – temperature, Volts, Amps, Ohms
 - electrical testing – voltage, current, resistance
- appropriate test equipment used accurately – multimeters, diagnostic testers, oscilloscopes, signal generators, logic probes, data logger, flow meter, calibrators, temperature bath
- test record sheets to show:
 - manufacturer's specification compared with actual results
 - set parameters and tolerances using correct units and calculations, including temperature, voltage, current and resistance
 - discrepancies identified and explained where found.

Disassembly and re-assembly:

- procedures to follow:
 - decommissioning – isolation, cool down period, removal of sub-assemblies, removal of components, disconnection of wires
 - commissioning – connection of wires, installation of components, installation of sub-assemblies, powering up, connectivity checks, test before first use
 - return to service – final system checks, software simulations, functional tests
- quality monitoring and assurance checks and measures:
 - post-repair performance checks
 - checking and validating reliability and durability – screw connections are tightened, correctly matched crimps and wires, input variables match output variables, no exposed wiring or connections, appropriate circuit protection methods used, secure network, fully tested PLC programming
- re-instatement of the work area following procedures:
 - waste disposal – legal and regulatory requirements followed, wiring in the WEEE bin, recycling of materials where possible, non-recyclable materials to general waste bin
 - tools and equipment cleaned and returned to appropriate storage areas
 - clean and tidy the working areas.

Marks per band	1-4	5-8	9-12	12	24
Inspection and testing	<p>Some understanding and application of inspection and testing methods shown through selection and completion, using suitable test and measurement equipment, which may not be set up correctly.</p> <p>Basic interpretation and application of some parameters or tolerances. Some units of measurement and calculations used appropriately, but with limited accuracy.</p> <p>Some outputs, data or readings compared with manufacturer's specifications with discrepancies not always identified, following some recording procedures.</p>	<p>Good understanding and application of inspection and testing methods shown through the selection and completion, using suitable test and measurement equipment, set up correctly within tolerance.</p> <p>Clear interpretation and application of some parameters and tolerances. Most units of measurement and calculations used appropriately with some accuracy.</p> <p>Most outputs, data and readings compared with manufacturer's specifications with any discrepancies identified, following most recording procedures.</p>	<p>Comprehensive understanding and application of inspection and testing methods through the selection and completion, using suitable test and measurement equipment, set up correctly and with precision.</p> <p>Comprehensive interpretation and application of all parameters and tolerances. All units of measurement and calculations used appropriately and accurately.</p> <p>All outputs, data and readings compared with manufacturer's specifications with any discrepancies identified and explained, following all recording procedures.</p>		
Marks per band	1-4	5-8	9-12	12	
Disassembly and re-assembly	<p>Disassembly and re-assembly procedures (including decommissioning, commissioning and return to service) are carried out with some accuracy and measures to ensure reliability and durability.</p>	<p>Disassembly and re-assembly procedures (including decommissioning, commissioning and return to service) are carried out with some levels of accuracy and efficiency, with most measures to ensure reliability and durability.</p>	<p>Disassembly and re-assembly procedures (including decommissioning, commissioning and return to service) are carried out with high levels of accuracy and efficiency, with comprehensive measures to ensure reliability and durability.</p>		

	<p>Use relevant tools and equipment, including HMI/expert technologies, adequately throughout disassembly and re-assembly activities, with limited consideration for accuracy.</p> <p>Working area partially re-instated following some procedures, including some waste managed appropriately and disposed of with limited consideration of requirements.</p>	<p>Use a range of relevant tools and equipment, including HMI/expert technologies, appropriately throughout disassembly and re-assembly activities, with some consideration for accuracy and efficiency.</p> <p>Working area mainly re-instated following most procedures, including waste managed appropriately and disposed of with some consideration of requirements.</p>	<p>Use all tools and equipment, including HMI/expert technologies, appropriately throughout disassembly and re-assembly activities, with full consideration for accuracy and efficiency.</p> <p>Working area fully re-instated following all procedures, including waste managed appropriately and disposed of with full consideration of requirements.</p>		
--	--	---	---	--	--

Assessment theme – Working with faults

Guidance for assessors

Evidence from Task 2 should be used to assess performance against this assessment theme.

Task 2

- calibration results
- completed test record sheets
- updated maintenance records and control documents
- annotated method statement, including any recommendations for further investigation if required
- assessor observations of the maintenance activities
- assessor observation of system functionality demonstration
- photographic evidence of:
 - test set up for calibration
 - top of the thermocouple to show the wiring of the replaced transmitter, including connections.

Note: where there is insufficient evidence to award a mark, a zero mark must be given	Band 1 descriptor	Band 2 descriptor	Band 3 descriptor	Total marks per sub assessment theme	Total marks for assessment theme
	<p>Indicative content: Detection and diagnosis:</p> <ul style="list-style-type: none"> • fault detection and diagnostic techniques – self-diagnosis, unit substitution, input output, half split technique, 6 point technique, sensory checks • faults to be found - remote monitoring system offline, open circuit from the sensor, failed transmitter potentiometer, PLC program has been inputted incorrectly • diagnostic and measurement information – test record sheets, system operation data, maintenance records, reported faults, fault history, errors, drifting, reliability 				

	<ul style="list-style-type: none"> • schedule of tasks – list of tasks to complete considering logical order of fault resolution, to reduce system downtime, complete resolution tasks with efficiency, for example resolving the offline remote monitoring system first as this could provide further information on subsequent faults. <p>Resolution:</p> <ul style="list-style-type: none"> • resolution methods – reconnecting network to restore connectivity, replacing wires in the open circuit, remove and replace failed potentiometer, reprogramming the PLC • processes - <ul style="list-style-type: none"> ○ interpreting data and manufacturer’s specifications ○ recording – annotate method statement with updates from work carried out, components replaced and actions taken, repairs made ○ standards – WEEE, IET, IEEA • quality of repairs - screw connections are tightened, correctly matched crimps and wires, input variables match output variables, no exposed wiring or connections, fully tested PLC programming, calibrated to manufacturer’s specifications • calibration values within operational specification to ensure system accuracy. 				
Marks per band	1-3	4-6	7-9	9	15
Working with faults – detection and diagnosis	<p>Limited fault detection and diagnostic techniques carried out demonstrating basic knowledge and application of fault finding.</p> <p>One or two faults correctly diagnosed using at least one appropriate fault detection and diagnostic technique, performed with some accuracy.</p>	<p>Good fault detection and diagnostic techniques carried out with some success, demonstrating good understanding and application of fault finding with minor inaccuracies.</p> <p>Three faults correctly diagnosed using some appropriate fault detection and diagnostic techniques, performed mostly accurately.</p>	<p>Thorough fault detection and diagnostic techniques carried out systematically and logically, demonstrating comprehensive understanding and application fault finding.</p> <p>All four faults correctly diagnosed using a range of fully appropriate fault detection and diagnostic techniques, performed fully accurately and with precision.</p>		

	Some diagnostic and measurement information used to determine the causes of the faults and create a limited schedule of tasks for reactive and preventative maintenance activities.	Most diagnostic and measurement information used to determine the causes of the faults and create a clear schedule of tasks for reactive and preventative maintenance activities.	All diagnostic and measurement information used to determine the causes of the faults and create a comprehensive and logical schedule of tasks for reactive and preventative maintenance activities.		
Marks per band	1-2	3-4	5-6	6	
Working with faults - Resolution	<p>Resolution methods identified but may not be fully effective, with minimal reference to manufacturer's specifications and brief consideration of recording procedures.</p> <p>One or two faults repaired to an acceptable standard, with limited consideration of timeframes or standards, and following processes.</p> <p>Calibrations completed, but not working within specified tolerances.</p>	<p>Resolution methods identified from diagnostic and measurement information are effective with some reference to manufacturer's specifications, following recording procedures.</p> <p>Three faults repaired to a good standard, with clear consideration of timeframes and standards, and following processes.</p> <p>Calibrations completed and working mostly within specified tolerances.</p>	<p>Effective and efficient resolution methods selected from diagnostic and measurement information with thorough reference to manufacturer's specifications, comprehensively recording throughout rectification.</p> <p>All four faults repaired to a high standard, with full consideration of timeframes and standards, and following processes.</p> <p>Calibrations completed and working fully within specified tolerances.</p>		

Assessment theme – Reviewing and reporting

Guidance for assessors

Evidence from Tasks 2, 3a, 3b and 4 should be used to assess performance against this assessment theme.

Task 2

- calibration results
- completed test record sheets
- updated maintenance records and control documents
- annotated method statement, including any recommendations for further investigation if required
- assessor observation of system functionality demonstration.

Task 3a

- technical report
- revised maintenance schedule, including justifications.

Task 3b

- maintenance schedule amended from peer review feedback, including justifications
- completed peer review forms.

Task 4

- handover documentation
- assessor observations of the handover meeting
- video evidence showing the handover meeting with the supervisor.

Note: where there is insufficient evidence to award a mark, a zero mark must be given	Band 1 descriptor	Band 2 descriptor	Band 3 descriptor	Total marks per sub assessment themes.	Total marks for assessment theme
--	--------------------------	--------------------------	--------------------------	---	---

	<p>Indicative document:</p> <p>Reviewing:</p> <ul style="list-style-type: none"> • updated maintenance schedule from peer review feedback with adaptations/modifications and improvements with justifications. <p>Reports:</p> <ul style="list-style-type: none"> • technical report to cover: <ul style="list-style-type: none"> ○ review of the maintenance activities, including cost effectiveness and time management ○ evaluation of fault detection and diagnosis methods effectiveness and suggestions for future improvements ○ fault resolution effectiveness and how to improve in future ○ any outstanding faults, including recommendations that may require attention before the next planned maintenance activity ○ waste disposal methods followed – hazardous waste, recycling, electrical, general ○ reporting to manage stock levels, materials or resources • technical documentation to update and amend - calibration records, software updates program, maintenance records, maintenance schedules and system representations (schematics, block diagram, wiring diagram), control documents • amendments – digital/physical, component changes, software version, labelling, symbols, wiring layouts. <p>Handover:</p> <ul style="list-style-type: none"> • procedures: <ul style="list-style-type: none"> ○ de-brief - modifications, faults, further investigation, suggested updates and improvements to maintenance schedules including justifications for not making suggested changes, confirmation of work completed, due date of next maintenance activity ○ signatures and date • documentation to handover - test and calibration results, maintenance schedules, updated drawings and diagrams, software update information, maintenance records • communication methods – written, verbal, media • demonstration of system functionality – system powers up, no error messages displayed on HMI, temperature output reading between set parameters, control functionality, description overall system operation, system powers off. 				

Marks per band	1-2	3-4	5-6	6	21
Reviewing	<p>Changes to maintenance processes and procedures as a result of feedback are not always suitable and lack reasoning, including a date for next planned maintenance activity which may not be fully appropriate.</p> <p>Where no improvements/adaptions are made to maintenance processes and procedures, this is supported with brief reasoning and justifications to why.</p>	<p>Changes to maintenance processes and procedures as a result of feedback are suitable with some reasoning, including an appropriate date provided for next planned maintenance activity.</p> <p>Where no improvements/adaptions are made to maintenance processes and procedures, this is supported with good reasoning and justifications to why.</p>	<p>Changes to maintenance processes and procedures as a result of feedback are suitable with detailed reasoning, including an appropriate date provided for next and future planned maintenance activities.</p> <p>Where no improvements/adaptions are made to maintenance processes and procedures, this is supported with detailed and thorough reasoning and justifications to why.</p>		
Marks per band	1-3	4-6	7-9	9	
Reports	<p>Follow, but not complete, reporting procedures to manage stock levels, materials or resources, with some consideration for accuracy.</p> <p>Basic technical reporting and evaluation of the maintenance completed, techniques and methods used, with some basic technical terms, which may not be fully accurate.</p>	<p>Follow and complete reporting procedures to manage stock levels, materials and resources, with clear consideration for accuracy.</p> <p>Clear technical reporting and evaluation of the maintenance completed, techniques and methods used, with some accurate industry standard technical terms.</p>	<p>Follow and complete detailed reporting procedures to manage stock levels, materials and resources, with full consideration for accuracy.</p> <p>Detailed technical reporting and evaluation of the maintenance completed, techniques and methods used, using fully accurate industry standard technical terms.</p>		

	Amendments to technical documentation made but may not be technically accurate or appropriate, with some reference to quality and assurance monitoring processes.	Mostly appropriate amendments to technical documentation made with some technical accuracy and reference to quality and assurance monitoring processes.	Fully appropriate and technically accurate amendments to technical documentation made with clear reference to quality and assurance monitoring processes.		
Marks per band	1-2	3-4	5-6	6	21
Handover	<p>Limited application of handover procedures using terminology partially appropriate to the audience.</p> <p>Some relevant documentation shared as part of handover procedure with limited explanation, using appropriate communication methods but may not be fully effective.</p> <p>Brief operational demonstration of system functionality with some verbal description of work completed, which may not be communicated accurately.</p>	<p>Some application of handover procedures using mostly appropriate terminology to the audience.</p> <p>Most relevant documentation shared as part of handover procedure with some explanation, using a range of appropriate communication methods.</p> <p>Sufficient operational demonstration of system functionality with clear verbal description and explanation of work completed, mostly communicated accurately.</p>	<p>Complete application of handover procedures, using correct terminology fully appropriate for audience.</p> <p>All relevant documentation shared as part of handover procedure with detailed explanation, using a range of relevant and effective communication methods.</p> <p>Thorough operational demonstration of system functionality with detailed verbal description and explanation of work completed, communicated accurately.</p>		

6. Links to Maths, English and Digital Skills

The table below indicates where each of the General Maths, English and Digital Competencies have been integrated into the assignment tasks.

Task	Skills
1	EC1, EC2, EC3, EC4, EC5, EC6, MC2, MC3, MC4, MC5, MC6, MC7, MC8, MC9, MC10, DC1, DC2, DC4, DC5
2	EC5, EC6, MC1, MC2, MC3, MC4, MC5, MC6, MC7, DC1, DC4, DC6.
3	EC1, EC2, EC3, EC4, EC5, EC6, MC2, MC5, MC7, MC8, MC10, DC1, DC2, DC3, DC4, DC5, DC6
4	EC1, EC2, EC3, EC4, EC5, EC6, MC10, DC1, DC2, DC3, DC4, DC5.

7. Peer Review Form

Candidate name	Candidate number
Centre name	Centre number

Peer review form

Question	Feedback
How well does the schedule enable planned maintenance activities to be performed and recorded over time?	
How appropriate are the recommended planned maintenance intervals and why?	
What are the implications to the business of the proposed maintenance schedule?	
How could the maintenance schedule be optimised/ improved?	

8. Declaration of authenticity

Assessment ID	Qualification number
Candidate name	Candidate number
Centre name	Centre number

Additional Support

Has the candidate received any additional support in the production of this work?

No **Yes** (Please tick appropriate)

If yes, give details below (and on a separate sheet if necessary).

--

Candidate:

I confirm that all work submitted is my own, and that I have acknowledged all sources I have used.

Candidate signature	Date

Assessor:

I confirm that all work was conducted under conditions designed to assure the authenticity of the candidate's work, and am satisfied that, to the best of my knowledge, the work produced is solely that of the candidate.

Assessor signature	Date

Note: Where the candidate and/or assessor is unable to or does not confirm authenticity through signing this declaration form, the work will be returned to the centre and this will delay the moderation process. If any question of authenticity arises, the assessor may be contacted for justification of authentication.

9. Candidate Record Form (CRF) – Exemplar

T level technical qualifications

(T level Technical Qualification – Control and Instrumentation Occupational Specialism)

Candidate name	Candidate number
Centre name	Centre number

Marker Notes – Please always refer to the relevant marking grid for guidance on allocating marks and make notes which describe the quality of the evidence and justification of marks.

Please record any guidance, intervention (including Health and Safety) or feedback that is given to a candidate.

Expand boxes as required.

Health and safety												
	1	2	3	4	5	6	7	8	9	10	11	12
Mark	Notes and justification											

Planning and preparation										
Planning										
	1	2	3	4	5	6	7	8	9	
Mark	Notes and justification									
Preparation										
	1	2	3	4	5	6	7	8	9	
Mark	Notes and justification									

Systems and components												
Inspection and testing												
	1	2	3	4	5	6	7	8	9	10	11	12
Mark	Notes and justification											
Disassembly and reassembly												
	1	2	3	4	5	6	7	8	9	10	11	12
Mark	Notes and justification											

Working with faults										
Detection and diagnosis										
	1	2	3	4	5	6	7	8	9	
Mark	Notes and justification									
Rectification										
	1	2	3	4	5	6				
Mark	Notes and justification									

Reviewing and reporting									
Reviewing									
	1	2	3	4	5	6			
Mark	Notes and justification								
Reports									
	1	2	3	4	5	6	7	8	9
Mark	Notes and justification								
Handover									
	1	2	3	4	5	6			
Mark	Notes and justification								

Internal assessor signature	Date

Total

The T Level is a qualification approved and managed by the Institute for Apprenticeships and Technical Education.

Copyright in this document belongs to, and is used under licence from, the Institute for Apprenticeships and Technical Education, © 2021. 'T-LEVELS' is a registered trademark of the Department for Education. 'T Level' is a registered trademark of the Institute for Apprenticeships and Technical Education. 'Institute for Apprenticeships & Technical Education' and logo are registered trademarks of the Institute for Apprenticeships and Technical Education.

We make every effort to ensure that the information contained in this publication is true and correct at the time of going to press. However, City & Guilds' products and services are subject to continuous development and improvement, and the right is reserved to change products and services from time to time. City & Guilds cannot accept responsibility for any loss or damage arising from the use of information in this publication.

The City & Guilds of London Institute. All rights reserved. City & Guilds is a trademark of the City & Guilds of London Institute, a charity established to promote education and training registered in England & Wales (312832) and Scotland (SC039576). City and Guilds Group Giltspur House, 5–6 Giltspur Street London EC1A 9DE