

T Level Technical Qualification in Design and Development for Engineering and Manufacturing (8714-31)

Mechanical Engineering (321)

**Guide standard exemplification
material**

Threshold competence – Sample

First teaching from September 2022

Version 1.1

Version and date	Change detail	Section
1.1 January 2023	Formatting of Task 1 evidence requirements	Task 1

Contents

Introduction	3
Grade descriptors	4
Task 1 – Design	5
1a) <i>Design specification</i>	6
1b) <i>Annotated sketches</i>	8
1c) <i>Justification of the choice of one design for further development.....</i>	10
1d) <i>Justification of the selection of the materials and components</i>	11
1e) <i>Design calculations</i>	14
1f) <i>Engineering drawings</i>	16
1g) <i>Outcomes of the virtual modelling of the proposed design.....</i>	19
1h) <i>Bill of materials.....</i>	21
Task 2 – Manufacture and test.....	23
2a) <i>Risk assessment.....</i>	24
2b) <i>Manufacture of the prototype</i>	26
2c) <i>Testing.....</i>	35
Task 3 – Peer review	38
<i>Peer review feedback form</i>	39
Task 4 – Evaluation and implementation.....	41
4a) <i>Outcomes of virtual modelling.....</i>	42
4b) <i>Revision control document.....</i>	44
4c) <i>Evaluation and implementation report</i>	46

Introduction

The sample assessment materials within this document refer to the T Level Technical Qualification in Design and Development for Engineering and Manufacturing - Mechanical engineering occupational specialism sample assignment. The aim of these materials is to provide centres with examples of knowledge, skills and understanding that attest to minimal threshold competence. The examples provided do not reflect all evidence from the sample assignment as the focus of this material is the quality and standards that need to be achieved rather than the volume of exemplar evidence provided. However, the examples provided are representative of all tasks in the sample assignment. The evidence presented here has been developed to reflect minimal threshold competence within each task but is not necessarily intended to reflect the work of a single candidate. It is important to note that in live assessments a candidate's performance is very likely to exhibit a spikey profile and the standard of performance will vary across tasks. Minimal threshold competence will be based on a synoptic mark across all tasks.

The materials in this Guide Standard Exemplification Material (GSEM) are separated into three sections as described below. Materials are presented against a number of tasks from the assignment.

Task

This section details the tasks that the candidate has been asked to carry out, what needs to be submitted for marking and any additional evidence required including any photographic evidence. Also referenced in this section are the assessment themes the candidates will be marked against when completing the tasks within it. In addition, candidate evidence that has been included or not been included in this GSEM has been identified within this section.

In this GSEM there is candidate evidence from:

Task 1

Task 2

Task 3

Task 4

Candidate evidence

This section includes exemplars of candidate work, photographs of the work in production (or completed) and practical observation records of the assessment completed by centre assessors. This will be exemplar evidence that was captured as part of the assessment and then internally marked by the centre assessor.

Commentary

This section includes detailed comments to demonstrate how the candidate evidence attests to the standard of minimal threshold competence by directly correlating to the grade descriptors for this occupational area. Centres can compare the evidence against the performance indicators in the marking grid descriptors within the assessor packs, to provide guidance on the standard of knowledge, skills and understanding that need to be met for minimal threshold competence.

It is important to note that the commentary section is not part of the evidence or assessment but are evaluative statements on how and why that piece of evidence meets a particular standard.

Grade descriptors

To achieve a pass (threshold competence), a candidate will typically be able to:

Demonstrate a basic use of software/ technologies to model, evaluate and produce mechanical engineering diagrams and simulations that meets the requirements of the brief.

Demonstrate basic technical skills when developing models and prototypes, resulting in a model that may require some modifications.

Apply basic knowledge and understanding of testing processes, resulting in a model that has been tested against most of the design criteria.

Interpret information, plan, assess risk and follow safe working methods appropriately when applying practical skills to an acceptable standard in response to the requirements of the brief.

Apply basic knowledge and understanding of the design principles required for mechanical engineering resulting in proposals and solutions that meet the minimum requirements of the brief.

Work safely showing an understanding and suitable level of awareness in the preparation and application of processes, selection and use of tools and manufacturing materials and components, resulting in tasks that are carried out with some minor errors.

Use industry and technical terminology accurately most of the time in both written and verbal contexts.

Task 1 – Design

(Assessment themes: Health and safety, Design and planning, Manufacturing, Reports)

For task 1, candidates need to produce the following pieces of evidence:

- a) design specification
- b) up to three annotated sketches
- c) justification of the choice of one design for further development
- d) justification of the selection of the materials and components
- e) design calculations, including all workings
- f) engineering drawings of the proposed design
- g) outcomes of the virtual modelling of the proposed design, either as screen captures or printouts
- h) bill of materials.

For Task 1, the following additional evidence may also be submitted:

- any notes produced of research undertaken including citation of sources and internet search history.

1a) Design specification

Candidate evidence

Requirements from design criteria:

- The lifting device must be manually powered.
- It must reduce the effort required by workers to raise the load.
- It must be capable of lifting a cuboid box of maximum mass 15 kg.
- It must be capable of lifting a cuboid box of maximum width, depth and height each 500 mm.
- It must be capable of lifting the load from 100 mm above ground level to a height of 1 m and returning to its start position.
- The lifting platform must allow a human worker to push the box off onto a packing table.
- The lifting activity must be carried out safely.

Design specification:

Building on the requirements of the design brief, I have created the following design specification:

- The minimum size of the lifting platform must be 600 × 600 mm, in case loading is not accurate when the box is pushed onto it.
- The device must be capable of lifting 147 N, representing the maximum weight of the box.
- The maximum effort required to raise the load should be 107 N, as ergonomic tables show this is the maximum sustainable force by an adult.
- The device should give a mechanical advantage of at least 2.3 to lift the maximum load, based on the ergonomic tables.
- The device must be capable of lifting the load from 100 mm above ground level to a height of 1 m to allow the boxes to be loaded/unloaded, as specified in the brief.
- The device must be able to return to its start position so that it can be reused, as specified in the brief.
- The mechanism must be at a convenient height for the operator to avoid repetitive strain injuries.
- It must be lightweight so it can be manually handled by one operator.
- The platform must have no sharp edges, so that the worker using it is not cut.
- Any parts that move or rotate must be guarded or covered, to avoid finger traps causing injuries.
- The lifting platform should be made from either aluminium or steel, as these are readily available, less expensive than alternative metals, and would be resistant to minor knocks and impacts that could occur in a stores environment.
- At least 70% of the materials used in the device should be recycled or recyclable, to reduce the impact on the environment.
- The device should be made from standard-sized forms of material, to minimise the manufacturing costs incurred.

Commentary

The candidate has produced a brief design specification in response to the task that builds on the design criteria. The candidate has largely structured and focused their design specification to reflect the specific design criteria points that have been given, including reference to health and safety considerations relating to the height and the weight of the mechanism, so they can be operated safely. They have also briefly considered some additional factors, such as sustainability and the form of the materials to be used.

There are a few minor inaccuracies in technical knowledge, for example the candidate's comment that 'The mechanism must be at a convenient height for the operator to avoid repetitive strain injuries' – it is not the height of the mechanism that is important in that case, but the handle/device to operate it. Additionally, the specified value for the maximum effort required does not take into account either the weight of the lifting platform or inefficiencies in operation for example due to friction.

Most points have been analysed or elaborated on, but there are some elements that would benefit from further detail, such as the materials being recycled or recyclable and the device being made from standard-sized forms of material.

To develop their response further, the candidate could have included elaboration to all of the points mentioned, for example explaining why standard forms of material are to be used, which could be on the grounds of cost, availability or timescale. They could also have provided further analysis of each point made, for example giving a tolerance for height at which the lifting platform must be positioned and explaining why this is required. In addition, they could have considered additional factors that would influence the development, such as the operating environment, cost and aesthetics, and the manufacturing resources available or required to produce the prototype.

1b) Annotated sketches

Candidate evidence

Sketch 1

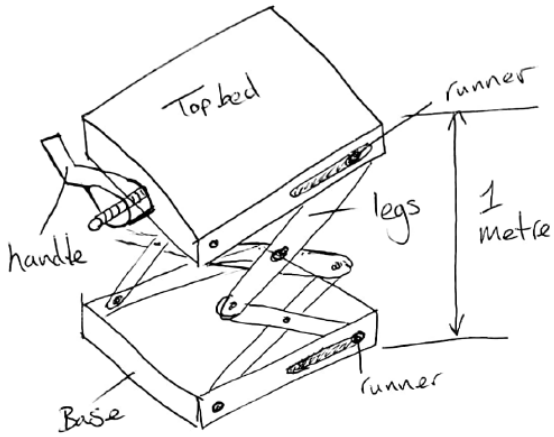

Mechanisms

1 - At top - wind handle on threaded bar to pull legs on runners.

or

2 - At the middle - wind threaded bar through the legs to raise the bed.

Top bed and Base dimensions - $610 \times 610 \times 5\text{mm}$
x2 - Top + base

Leg dimensions - x8 - $25 \times 610 \times 3\text{mm}$

Runner dimensions - x2 - $610 \times 5\text{mm}$

x12 Fixings for legs hinge points - nuts, bolts, washers M5

Threaded bar - $720 \times 5\text{mm}$ @ 1.5 pitch

Sides of top and base - $25 \times 25 \times 5\text{mm}$ @ lengths of 610×8 .

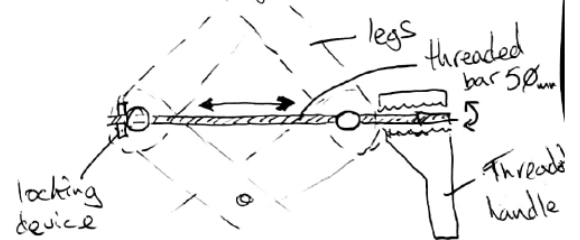
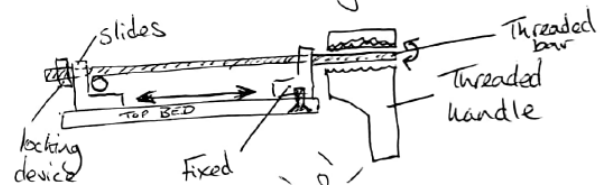

Sketch 2

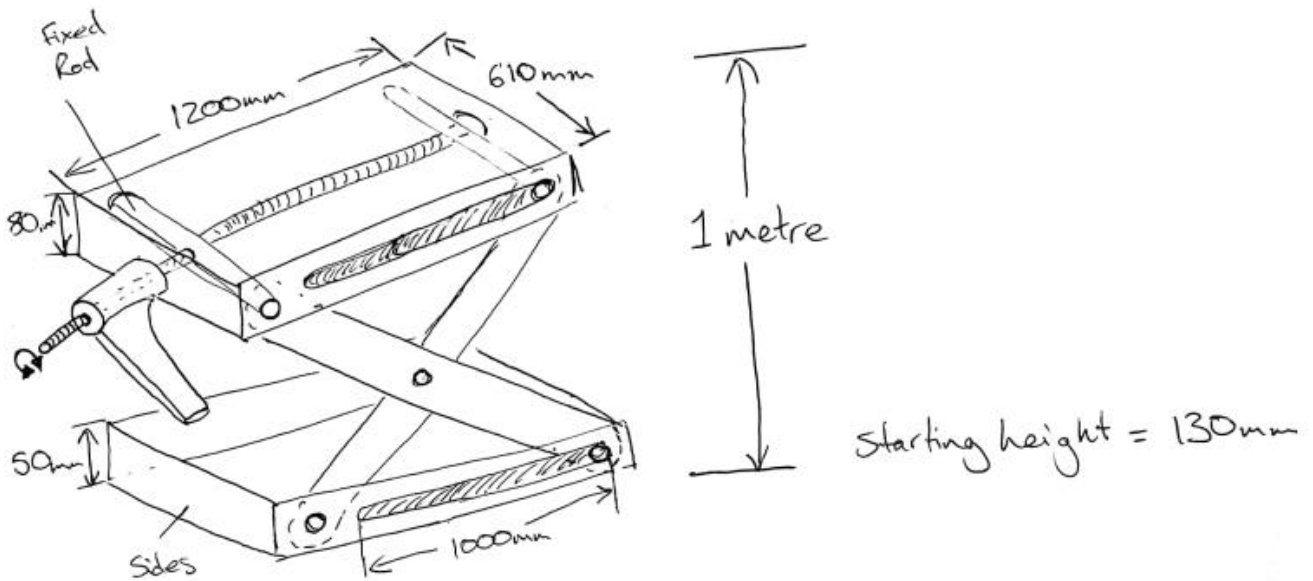

Threaded bar dimension - 1.5 pitch $6\text{mm } \varnothing \times 1500\text{mm}$
 Rod - $310 \times 8\text{mm } \varnothing \times 4$
 Legs - $\times 4 - 1200 \times 50 \times 3\text{mm}$
 Top and base - $3\text{mm} \times 1200\text{mm} \times 610\text{mm} - \times 2$
 Base Sides - $3\text{mm} \times 50\text{mm} \times 610 - \times 2$
 $3\text{mm} \times 1200 \times 50\text{mm} - \times 2$
 Top sides - $3 \times 8 \times 610 - \times 2$
 $3 \times 8 \times 1200 \times 2$

Commentary

The variety of mechanisms between the two design sketches shows that the candidate has a good knowledge and understanding of the requirements and potential solutions, although with some gaps. There is some detail in the annotations, such as the use of concertinaing legs, so that the platform can go low enough and use of runner rails as a leverage point. However, there are also a few gaps in the knowledge, such as methods of securing linkages, where further development of the design is needed. Although, based on appearance, both designs could meet the main requirements of the design criteria, it is not clear that all the specification requirements would be met. For example, there are no comments relating to health and safety criteria.

To develop their response further, the candidate could have included additional annotations and/or some detailed sketches of specific features to show that they have considered their effective operation and how the designs meet all the needs of their design specification. The candidate could have also labelled the two different mechanisms in sketch 1, for ease of reference.

1c) Justification of the choice of one design for further development

Candidate evidence

Both designs have a lifting platform, which is big enough and should be able to accommodate the size and weight of the boxes. They also both have handles that will need to meet ergonomic dimensions for repetitive use. The effort required to rotate these handles will have to be considered further during the later stages to prevent repetitive strain injury.

The lift in sketch 2 is longer than required, which can become a potential health and safety hazard. The lift will also not go low enough, after initial calculations were done. For these reasons, I will not be using sketch 2.

For the lift in sketch 1, I have considered two mechanisms that would be feasible. After I did some calculations, I realised that mechanism 2 would use more material, which would affect the weight of the lifting platform. Then after some further calculations I realised that this mechanism would not allow the lift low enough to meet the specifications of the brief. Therefore mechanism 1 is the most appropriate mechanism to use for this design.

The top bed in sketch 1 would measure 610 × 610 which would accommodate sufficiently the required dimensions of the box. By using mechanism 1, the legs will be smaller. Nuts and bolts have been considered for hinges, but this may change due to the thickness of the heads and may be considered later during the manufacture of the prototype.

Commentary

The candidate has provided some information about each design, highlighting some of their advantages and limitations. The justifications provided are correct and relevant to the design, but the level of detail provided is limited. The candidate makes a recommendation to proceed with sketch 1, however the structure of the justification could have been clearer with a more direct comparison of the two proposals. The justification of the rejection of sketch 2 is brief, but the candidate provides more detail for sketch 1. The candidate has included some appropriate health and safety considerations in the justification of their choice.

To develop further, the candidate could have considered how each of the design proposals meets each of the stated design criteria in detail rather than generically or against only a few of the design criteria. They could have also added more detail relating to cost and manufacturing possibilities of each design proposal.

1d) Justification of the selection of the materials and components

Candidate evidence

Material	Stainless steel
Properties	Resistance to corrosion High tensile strength Tough Good hardness Durable Resistance to temperature
Where this would be used	Base and lifting platform, handle, legs
Form of supply	Sheet and bar / rod
Ease of manufacture	Hardness means it can be difficult to cut and drill. Relatively straightforward to weld. Sheets can be fabricated into forms using standard workshop equipment.
Material positives	Durable and tough – would resist minor knocks and impacts in the stores and when moved. It has a high tensile strength, so should be able to support the boxes. Wouldn't need painting due to corrosion resistance.
Material negatives	Relatively expensive compared to other ferrous metals. High density (approximately 8000 kg/m ³) which would mean that it could be quite heavy and difficult to move around.

Material	Mild steel
Properties	High tensile strength High toughness Good weldability Prone to oxidation / rusting
Where this would be used	Base and lifting platform, handle, threaded bar
Form of supply	Sheet and bar / rod including threaded.
Ease of manufacture	Easier to cut and drill than stainless steel as not as hard. Easier to weld than stainless – could use various processes to join parts together. Easier to fabricate sheets into required forms using standard workshop equipment than for stainless steel.
Material positives	Relatively cheap compared to most metals and readily available in a wide range of standard sizes.
Material negatives	Rusts – needs painting or coating. Density approximately 7850 kg/m ³ slightly less than stainless but it could still be quite heavy and difficult to move around.

Material	Aluminium alloy
Properties	Low density Fair strength and hardness Ductile Good toughness Excellent corrosion resistance
Where this would be used	Base and lifting platform, handle
Form of supply	Sheet and bar / rod
Ease of manufacture	Easier to machine than the ferrous metals due to lower hardness. Can be difficult to weld – would need to use the TIG process. Easier to fabricate sheets into required forms using standard workshop equipment than for ferrous metals due to higher ductility and lower strength.
Material positives	Lower density (2700 kg/m ³) and good strength-to-weight ratio means compared to ferrous metals means that the design could be light weight which could make the lifting device easier to move around. Relatively easy to cut, drill and fabricate. Corrosion resistant so no finish would need to be applied to the device.
Material negatives	More expensive than ferrous metals. Can be harder than some materials to achieve a strong weld and would need to use the TIG welding process to join parts together, which requires higher skill than MIG welding.

Material	Brass
Properties	Moderate strength Corrosion resistance Aesthetically pleasing appearance
Where this would be used	Handle
Form of supply	Bar and rod
Ease of manufacture	Easier to cut, drill and turn than aluminium alloy. Can be difficult to weld – would need to use the brazing process.
Material positives	Good aesthetic appearance. Corrosion resistant so the lifting device would not need to have an applied finish. Relatively easy to turn compared to other metals.
Material negatives	Relatively expensive compared to both aluminium alloys and stainless steel. High density (8730 kg/m ³) so would add more to the weight of the device than other metals.

Considering the above, I will use mild steel for the base, lifting platform, mechanism and runner rails, as this has good strength and toughness, so would be able to lift the boxes without bending and be resistant to knocks and minor impacts which can occur in the stores area. Also, it is available in a broad range of standard sizes and is the lowest cost. It will need to be painted though, to stop rusting. For the handle I will use brass, as this is relatively easy to turn and aesthetically pleasing, although costly.

Commentary

Most of the key materials to meet the brief have been identified, although the mechanical fixings (nuts and bolts) and any required welding consumables are missing, and considerations are limited to common metals – these could have been improved by considering specific grades of the metals or specific alloys. There is some reasoning provided for most of the material choices (although not the fixings), this is generic and lacks depth and detail. For example, the requirement of the runner rails is identified, but the specific operating characteristics needed (size, load etc.) are not specified.

To improve the reasoning for the material selection, the choices could have been justified by quantification relative to the specific requirements of the application. For example, by providing estimated cost data; and, as the maximum weight of the box is known, the load and potential stress in the metal could have been calculated and compared to the tensile strength of each material. Additionally, other factors could have been considered, such as detail of the finish required for a functional solution in terms of the material and cost of application, for example the effect of painting or the advantages of applying a material like nylon to the surface of the lifting plate to increase the ease in pushing off the box. The specific availability, form, and processing requirements of the available materials could have been outlined in more detail.

1e) Design calculations

Candidate evidence

Mechanical advantage

From ergonomic tables at <https://ergoweb.com/force-guidelines/>:

Maximum manual lever force that can be applied = 29 lbs = 13 kg = 127.5 N

Maximum two-handed push pull force that can be sustained = 24 lbs = 10.8 kg (rounding down to avoid exceeding effort) = 105.9 N

Maximum load from box = $15 \times 9.81 = 147 \text{ N}$

$F=ma$

Mechanical advantage (MA) = output force / input force = load / applied force

With a lever = $147 / 127.5 = 1.15$

With a wheel = $147 / 105.9 = 1.38$

Operating size of the scissor lift

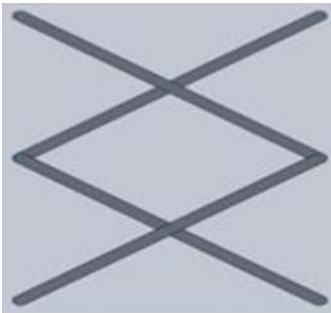

The scissor lift forms a diamond shape which can be considered as 4 triangles. If the angle at the base is 60 degrees when fully raised, then this gives an angle in each triangle of 30 degrees.

Using trigonometry, the length of each arm of the scissor lift = $300 / \cos 30 = 346 \text{ mm}$.

This means when fully opened out the width of the device could potentially be $346 \times 4 = 1384 \text{ mm}$ much higher than the required amount but reassuringly meeting the required height.

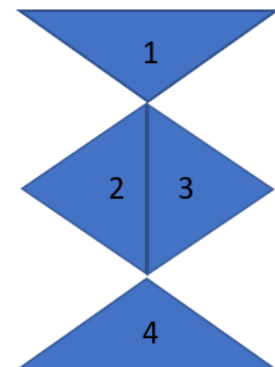

Mechanical advantage of the scissor lift

If the scissor lift has a pitch X_L of 3 mm, and a typical operating efficiency η of 0.3, then to raise a load of 147 N with a handle 200 mm long.

Work done on load = load $\times X_L = 147 \times 3 = 441 \text{ N mm}$

Work done by effort = work done on load / $\eta = 441 / 0.3 = 1470 \text{ N mm}$

FE = work done by effort / X_E where $X_E = 2\pi \times 200 = 1257 \text{ mm}$

FE = $1470 / 1257 = 1.16 \text{ N}$

Mechanical advantage = load / applied force = $441 / 1.16 = 380$

Risk of failure

Tensile failure

The cross-sectional area of platform = $w \times h = 0.003 \times 1.384 = 0.0041 \text{ m}^2$

Stress in lifting platform due to box = $F / A = 147 / 0.0041 = 36 \text{ kN} / \text{m}^2$

Even if the weakest material (aluminium) is used, this is significantly less than the yield stress of 90 MPa.

If the lifting arm is also made from 10 mm thick material with a width of 40 mm, then the stress in it = $F / A = 147 / (0.01 \times 0.04) = 3.67 \text{ kN} / \text{m}^2$ still significantly less than the yield stress of 90 MPa.

Risk of buckling - Maximum possible deflection of the lifting platform

$$I = bh^3 / 12 = 0.51 \times 0.01^3 / 12 = 4.25 \times 10^{-8} \text{ m}^4$$

Taking the lifting platform as a cantilever beam, and assuming the maximum mass of box is loaded at the opposite edge of the lifting platform and the base is made from the material with the lowest Young's modulus (aluminium), the maximum deflection at the end of the lifting platform furthest from the arm would be:

$$\delta_B = F L^3 / (3 E I) = 147 \times 1^3 / (3 \times 60 \times 10^9 \times 4.25 \times 10^{-8}) = 0.019 \text{ m or } 19 \text{ mm}$$

The worst case deflection of the lifting platform from this load could be 19 mm.

Commentary

The design calculations presented have been carried out correctly, however the methodology is not fully accurate as the candidate has not considered the weight of the lifting platform or lifting efficiency, for example due to the effect of friction. The example of the mechanical advantage of the scissor lift uses generic values which have not been justified in the context of this specific application. The calculation of the risk of buckling assumes a 'worst case' that is significantly worse than that which could result in practice from usual use, but would ensure a functional product.

To develop further, the candidate could have used the appropriate actual values for the scissor lift. The candidate could also have used the stress levels in the material caused by the activity to determine the resultant dimensions of the materials, rather than selecting the dimensions and then verifying that the stress levels were acceptable. They could also have refined the assumptions used for the buckling and estimated the total weight of the lifting assembly, based on using standard sized parts.

1f) Engineering drawings

Candidate evidence

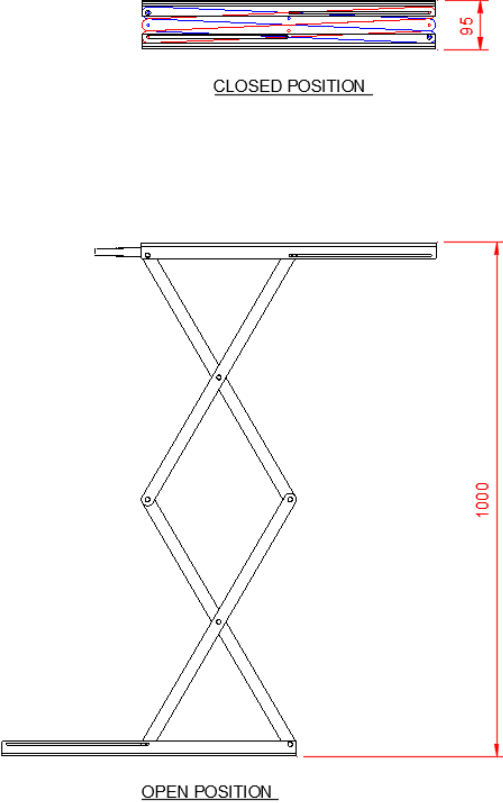
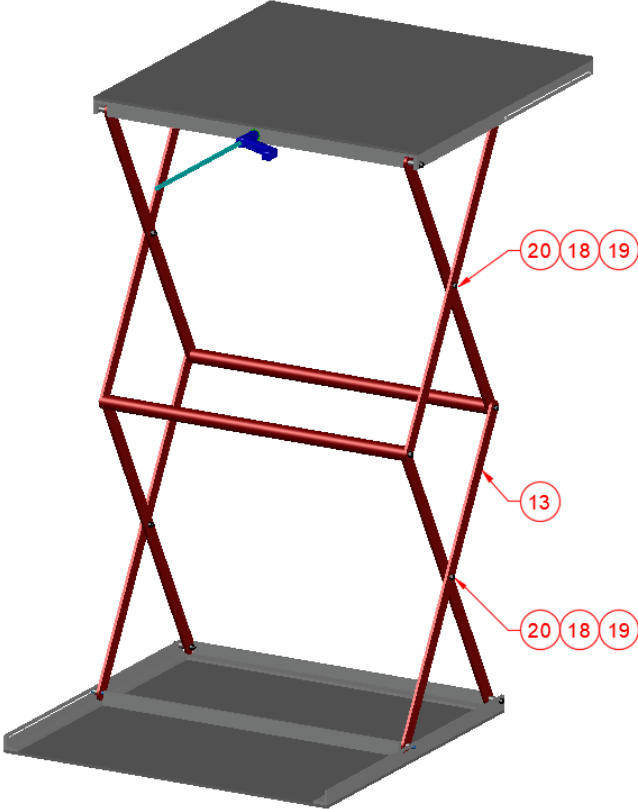

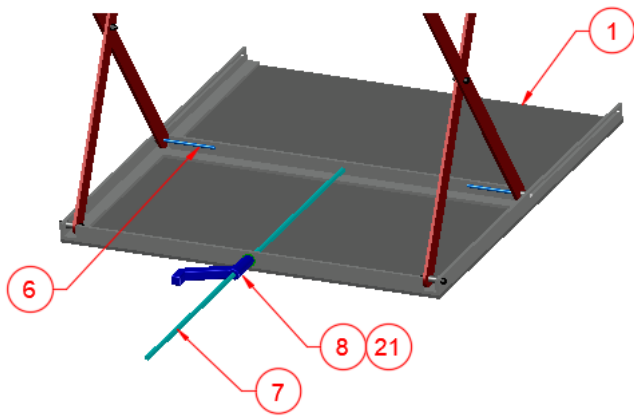

FRONT UNDERSIDE VIEW OF TOP PLATE

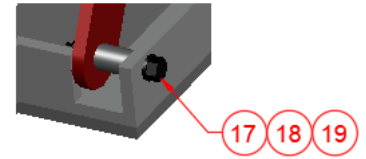

SCISSOR LEG / BRACKET CONNECTION DETAIL 1

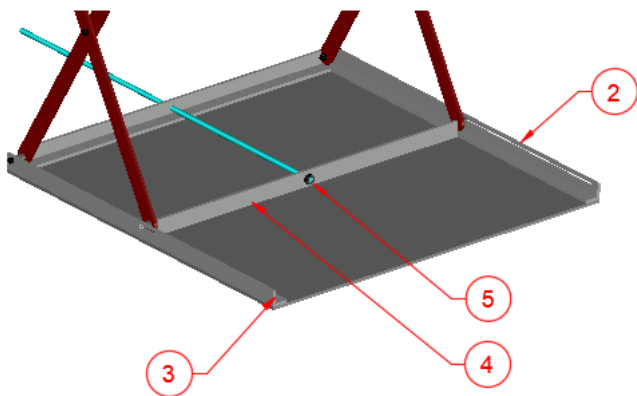

REAR UNDERSIDE VIEW OF TOP PLATE

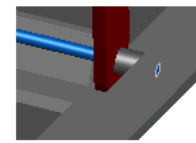

SCISSOR LEG / BRACKET CONNECTION DETAIL 2

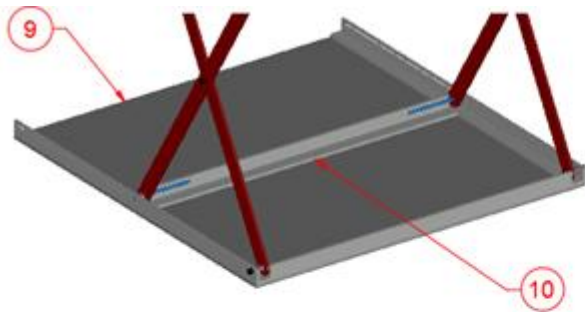

REAR UNDERSIDE VIEW OF BASE PLATE

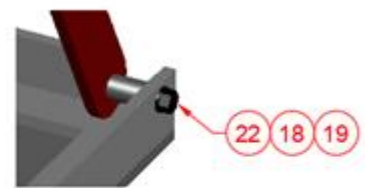

SCISSOR LEG / BRACKET CONNECTION DETAIL 1

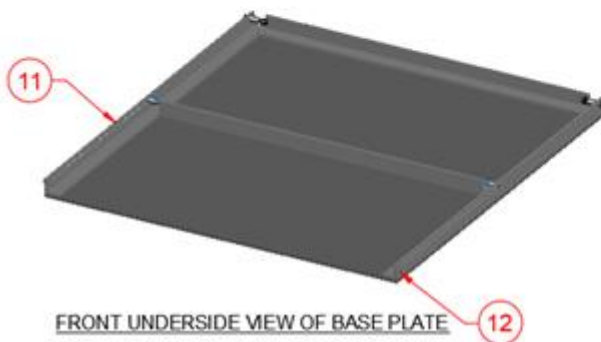

FRONT UNDERSIDE VIEW OF BASE PLATE

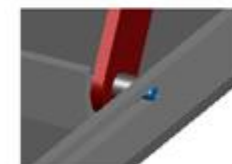

SCISSOR LEG / BRACKET CONNECTION DETAIL 2

PARTS LIST		
PART No.	DESCRIPTION	QUANTITY
1	TOP PLATE 600 x 600 x 5 THICK	1
2	TOP PLATE - SIDE BRACKET - RH - 25 x 25 x 5 THICK	1
3	TOP PLATE - SIDE BRACKET - LH - 25 x 25 x 5 THICK	1
4	TOP PLATE - SLIDE BRACKET - 25 x 25 x 5 THICK	1
5	WELDED NUT - M8	2
6	RUNNER RAILS - M5 x 100 LONG	4
7	STUDDING STAINLESS STEEL - M8 x 650 LONG	1
8	HANDLE - M8	1
9	BASE PLATE 585 x 585 x 5 THICK	1
10	BASE PLATE - SLIDE BRACKET - 25 x 25 x 5 THICK	1
11	BASE PLATE - SIDE BRACKET - LH - 25 x 25 x 5 THICK	1
12	BASE PLATE - SIDE BRACKET - RH - 25 x 25 x 5 THICK	1
13	SCISSOR LEG - 600 x 25 x 5 THICK	8
14	SCISSOR LEG BRACE - Ø25 x 550 LONG	2
15	SPACER - Ø10 x 10 LONG	4
16	SPACER - Ø10 x 15 LONG	4
17	BOLT - M5 x 35 LONG	2
18	WASHER - M5	16
19	NUT - M5	12

Commentary

The candidate has produced a set of engineering drawings for the main components, including a parts list. These are clear and offer multiple angles and close up views of the mechanism, however, there are some errors in the annotations and the parts list; for example balloons 15 and 16 are not seen in the isometric drawings and some details, such as the handle are missing from some views. The parts list has some minor errors, such as the quantities of items 5 and 19 and it is also missing items 20 to 22.

The drawings contain most of the information needed for a third party to manufacture the parts, but a few of the dimensions relating to the size of the top and base plates are not shown on the drawings, only in the parts list.

To improve, the drawings could show all the required dimensions and an assembly drawing or exploded view could be included to support the assembly of the prototype. The parts list could also be more accurate and include all the minor parts.

1g) Outcomes of the virtual modelling of the proposed design

Candidate evidence

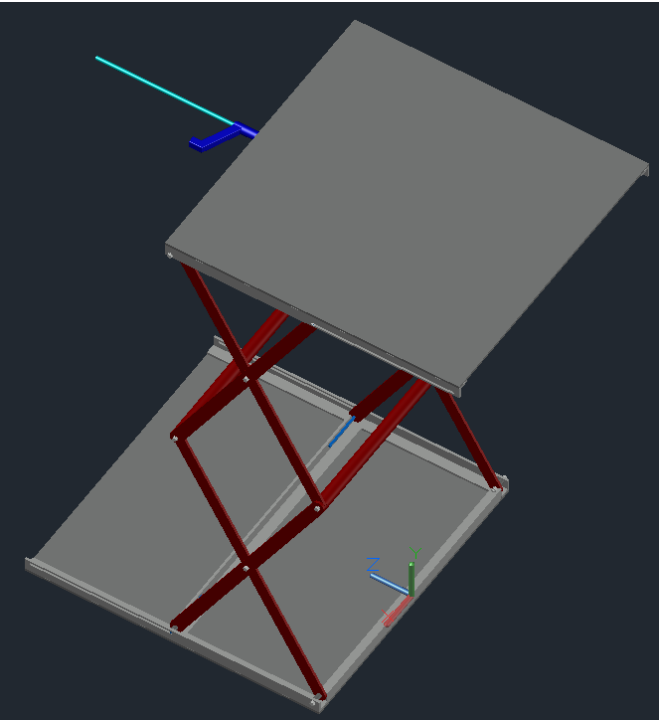
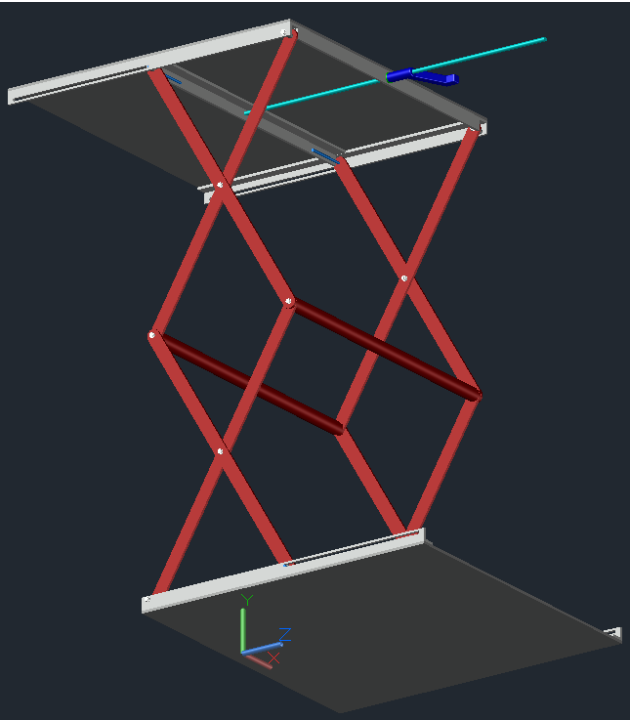
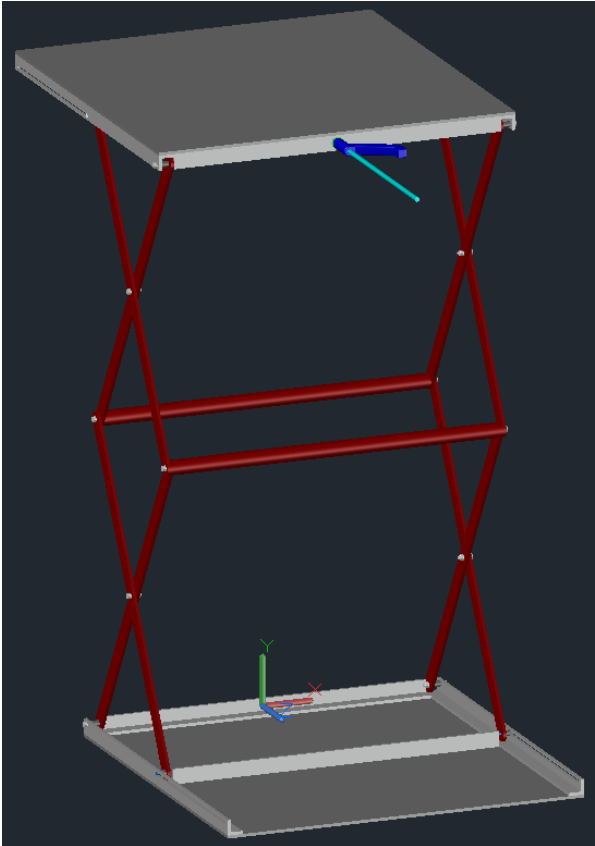
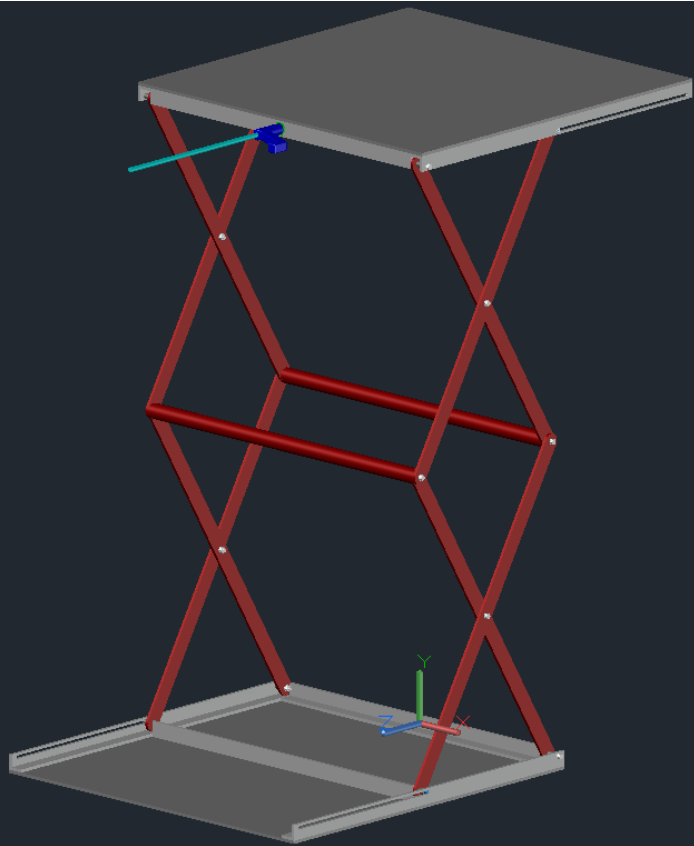

Commentary

The candidate has produced a good virtual model using 3D CAD software to show the appearance of the prototype and confirm the fit of the parts. The parts have been correctly aligned and positioned and the model is accurate and aligns with the engineering drawings. The model includes a good amount of visual detail of the plates, the handle and the scissor lift. The multiple angles included also give a good overview of the relative placement of the parts.

The model contains no annotations other than the axes, but these were included in the engineering drawings in part 1f, so they are not necessary here.

To improve, the candidate could have included some annotations in this view as well, such as the overall size of the plates or the height of the platform, demonstrating compliance to the design criteria.

1h) Bill of materials

Candidate evidence

I have compiled the following Bill of Materials. This outlines all of the materials and components that will be required to make the lift. The dimensions of each part are in the engineering drawings presented in part 1f.

Component	Material	Quantity	Reason
Lifting platform and base	Mild steel sheet, 3 mm thick, 610 x 610 mm	2	Stronger than aluminium (tensile strength 400 MPa compared to 90 MPa) but also higher density (7 g/cm ³ compared to 2.7 g/cm ³) so heavier if the same size. Costs less than other metals and readily available. Recyclable. Cut from sheet of standard thickness.
Rail runners	Stainless steel rod, 5 mm diameter x 610 m	4	Chosen as can be welded with ease to the mechanism.
Mechanism	Stainless steel M8 x 650mm long. 1.5 pitch, 1 m maximum raise	1	Strong material for the thread. Won't corrode, which could otherwise cause the device to jam over time.
Legs	Mild steel, 2 mm thick, 25 mm wide and 300 mm long	8	Cut from sheet of standard thickness. Reasons as above.
Handle	Stainless steel, 10 mm diameter x 200 mm long with internal thread	1	Strong so will not bend easily. Aesthetically pleasing. Resistant to corrosion from handling.
Knob for handle	Brass	1	Bought-in item as easier than making. Aesthetically pleasing.

Commentary

The candidate has produced a basic bill of materials that includes most main materials and components required to make the prototype, along with the quantities required, according to the dimensions of the components as shown in the engineering drawings. Appropriate quantities have been listed. However, the candidate has not included the mechanical fixings in the bill of materials needed to attach the screw jack and lifting arm to the base plate and lifting platform respectively.

Some basic reasoning has been provided for the choice of some of the materials, however this lacks depth and detail specific to this application.

To develop further, the candidate could have included all of the required materials and components for their design, such as the mechanical fixings, with detailed reasoning to justify the choice of each.

Task 2 – Manufacture and test

(Assessment themes: Health and safety, Manufacturing, Reports)

For task 2, candidates need to produce the following pieces of evidence:

- a) risk assessment
- b) manufactured prototype
- c) test records for the operation of the prototype.

- Assessor observation of:
 - manufacturing
 - testing the prototype.

Photographic evidence which shows:

- the step-by-step construction of the lifting device (photographs 1-6)
- the fit and relative orientation of the mechanical parts (photographs 6-11)
- the final prototype (photographs 7-11)

The following supporting evidence has not been included for this version of the guide standard exemplification materials:

Video evidence which shows:

- functionality of the prototype.

2a) Risk assessment

Candidate evidence

Hazard(s)	Risk(s)	Control measures	Risk rating	
			Likelihood	Severity
Working area	Slips, trips and falls	Ensure area is clean and tidy	3	1
Using a pillar drill during the manufacture of the prototype	Entanglement Ejected Wood chips, splinters Workpiece not held securely	Use machine guards Wear safety glasses Tie back hair and ties Use machine vice to secure work	2	2
Using a hacksaw during the manufacture of the prototype	Sharp edges on cut material Entanglement Workpiece not held securely	Use sufficient blade on the hacksaw Wear safety glasses Tie back hair and ties	1	3
Broken / poor handles on the tools	Stabbing or slipping with hand tools Inaccurate cutting lengths etc.	Visual safety inspection before use	3	2
Fire	Burns	Dispose of flammable waste Fire alarms and procedures	2	4
Using tap and die and hand tools during the manufacture of the prototype	Sharp edges on cut material	Wear gloves	2	1

Likelihood		Severity	
1	Very unlikely to happen	1	Minor injury
2	Unlikely to happen	2	Major injury
3	Possible to happen	3	Loss of limb
4	Likely to happen	4	Death of an individual
5	Very likely to happen	5	Multiple deaths

Commentary

The candidate has considered and identified the majority of hazards and risks associated with the manufacture of the prototype but has not considered the welding process. Control measures have been suggested to mitigate most of the risks, the exceptions being finger injuries on the guillotine and those arising during welding. The control measures given are generally appropriate, however lack detail, demonstrating the candidate may not have considered a variety of scenarios and situations that could arise during the making activities.

To develop the response further, the candidate would need to add further detail into their risk assessment. They could categorise each hazard separately for each process, demonstrating a deeper understanding of risks and the associated control measures.

Likelihood and severity have likewise been considered at a process level. It is unclear if the stated values take into account effect of the control measures.

2b) Manufacture of the prototype

Candidate evidence

I have decided to make the prototype out of wood as a substitute material as this cheaper and assessable to all centres (with and without metal fabrication department). The wood can demonstrate the required mechanical principles but with less strength and durability; therefore, as a prototype **only**, this allows for modifications and demonstration of feasibility. For the actual production of the lifting platform, steel should still be used.

I produced a scaled down version (1:2 ratio) and achieved a demonstration of the operation with scaled weight to match.



Photograph 1 shows the candidate's tool selection along with some components of the prototype. These are not neatly laid out, for example the screws are scattered and do not look as if they are counted to the correct quantity.



Photograph 2 shows the markings and assembly process of the prototype. The annotations are limited and only the location of the components is labelled. No measurement annotations have been added.



Photograph 3 shows the sides for the runner rails marked up. The lengths of the rails are not accurately cut (negotiable +/- 1-2 mm). The markings for the holes for the runners are missing and the level of detail is limited.



Photographs 4 and 5 show the marking out and the cut pieces. The marking is not very accurate and this resulted in the cutting being 1-2 mm short of the required length of 310 mm.



Photograph 6 shows the candidate's progression of building the prototype.



Photograph 7 shows the lifting platform at its lowest height of 50 mm, which meets the scaled dimensions required.

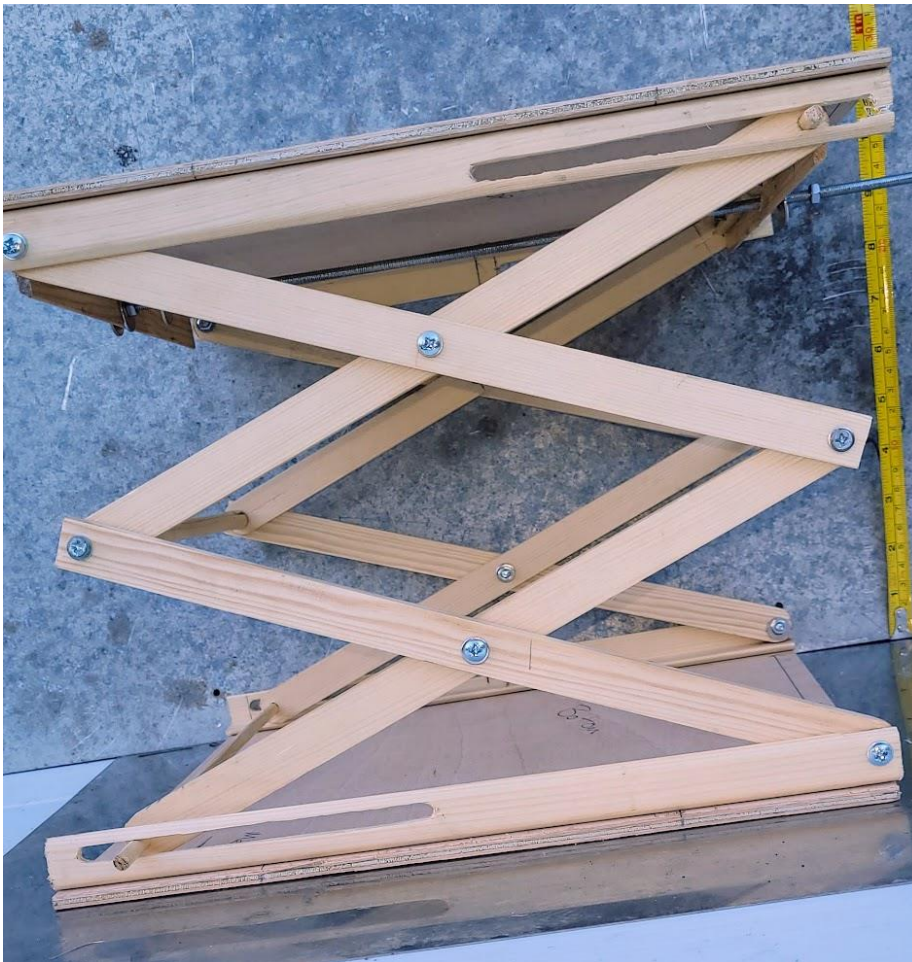

Photographs 8 and 9 show the platform lift at the halfway point. The lift is functional and can be raised and lowered as planned using the threaded bar mechanism.

Some of the cut legs of the scissor lift are not rounded off as per the drawings of the design, but they are still functional.



Photographs 10 and 11 show the platform lift fully extended to the maximum height. This meets the required scaled height of 500 mm. When fully extended, there is an imbalance and there is a risk of the platform tipping over if the load is placed on the unsupported end of the top platform.

Practical observation form - Prototype

Assessment ID	Qualification number
8714-321	8714-31
Candidate name	Candidate number
Candidate A	CG12345
Centre name	Assessment theme
City & Guilds	Health and Safety Manufacturing

Complete the table below referring to the relevant marking grid, found in the assessment pack. **Do not** allocate marks at this stage.

Task	Notes – <i>detailed, accurate and differentiating notes which identify areas of strength and weakness are necessary to distinguish between different qualities of performance and to facilitate accurate allocation of marks once all evidence has been submitted.</i>
Prototype	<p>The candidate correctly marked out the base and lifting platform using a rule, scribe and pencil. These were then cut to dimension using a hacksaw along with the rail runners and bar for the mechanism. When cutting the threaded bar, a good demonstration of accuracy and care was taken not to lose or damage the thread by placing nuts on the bar, before cutting to length.</p> <p>Some of the edges of the legs were not rounded off and the rods were cut with minor measurement inaccuracies, which contributed to an imperfect finish.</p> <p>The candidate then manually drilled holes using a pillar and handheld drill for accuracy. The drilled holes were not always centrally aligned. Glue was used as a welding substitute in order to assemble the lift. The accuracy of this could have been improved by the use of a positioning jig.</p> <p>All work was completed safely, with the candidate wearing the appropriate PPE. The candidate implemented the control measures in their risk assessment when using all of the manufacturing processes.</p> <p>Although most steps were completed correctly and competently, the accuracy of some manufactured parts was limited and there were variations in the finish around the cuts and where files had been used to remove burrs or sharp edges. The position of the runner rails required a small adjustment for operation. With these modifications the prototype was functional. The motion when the platform was raised or lowered was slightly jittery. During operation of the prototype, it was discovered that the lift would move in unintended directions (horizontal rather than vertical). This was due to the runner rails being on the same side of the lift.</p>

Assessor signature	Date
<i>Assessor 1</i>	03/04/2022

Commentary

The candidate completed the work safely. The selection of the tools was mostly appropriate, although could have been improved by using a jig for the drilling and gluing which would have resulted in increased accuracy.

The candidate demonstrated basic and effective use of tools, equipment and processes, which enabled the manufactured item to show functionality after rectification. However, there was an overall limited accuracy within some of the manufactured parts, as well as variation in finish. The candidate was also required to manually rectify to enable functionality.

The candidate produced a prototype that was mainly appropriate but required some modifications (to the runner rails and mechanism) to achieve functionality. It was identified as meeting most of the requirements of the design specification. The final product would be made in steel to meet all of the requirements of the brief.

2c) Testing

Candidate evidence

Test records

All testing was completed on a wooden substitute lift with a ratio of 1:2. All records have been converted to demonstrate the ability to meet the requirements in full dimensions.

Design criteria	How this was tested	Test outcome
The minimum size of the lifting platform must be 610 × 610 mm.	Measured with a meter rule.	Approx. 610 × 612 mm
The device must be capable of lifting 147 N.	Functional test with 15 kg box.	Pass
The maximum effort required to raise the load should be 107 N.	Not able to test but was easy to move during functional test.	
The device should give a mechanical advantage of at least 2.3 to lift the maximum load.	Design calculation.	MA > 100 Pass
The device must be capable of lifting the load from 100 mm above ground level to a height of 1 m.	Functional test with 15 kg box.	Pass
The device must be able to return to its start position so that it can be reused.	Functional test with 15 kg box.	Pass
The mechanism must be at a convenient height for the operator to avoid repetitive strain injuries.	Measured with a meter rule.	Height of handle ranged from 0.4 m to approx. 1.4 m
It must be lightweight.	Without having the metal, I cannot weigh the item, nor compare to my wood prototype.	N/A
The platform must have no sharp edges.	Silk test.	Couple of minor snags but no cuts
Any parts that move or rotate must be guarded or covered.	Visual inspection.	If a guard is added to final design will pass
At least 70% of the materials used in the device should be recycled or recyclable.	Device is all made in steel metal.	100% recyclable Pass
The device should be made from standard-sized forms of material.	Standard sizes used.	Pass

Practical observation form – Functional testing of the prototype

Assessment ID	Qualification number
8714-321	8714-31
Candidate name	Candidate number
Candidate A	CG12345
Centre name	Assessment theme
City & Guilds	Health and Safety Manufacturing

Complete the table below referring to the relevant marking grid, found in the assessment pack. **Do not** allocate marks at this stage.

Task	Notes – <i>detailed, accurate and differentiating notes which identify areas of strength and weakness are necessary to distinguish between different qualities of performance and to facilitate accurate allocation of marks once all evidence has been submitted.</i>
Testing of the prototype	<p>The candidate scaled down the lifting device to make testing feasible, all records were converted to what would be real if this was made from metal as proposed.</p> <p>The candidate tested starting and finishing height by winding up and down the lifting mechanism on the table with an appropriately mounted measuring tape. The candidate was provided with a box of the maximum dimensions and weight and performed an appropriate functional test.</p> <p>The candidate set up the device adjacent to the pre-positioned shelves provided by the centre to check starting and finishing height, however these were scaled down to match the scaling of the prototype. This was in a different location to the height testing but due to being made of wood the effort to relocate was minimal.</p> <p>The lifting platform was level with the entry picking shelf when positioned by the candidate. They had to exert effort to position the box as it didn't slide freely over the surface. The candidate then turned the handle to raise the box until it was slightly above the packing table, then pushed the box onto the packing table.</p> <p>Approximately 40 turns of the handle were required, which appeared to be relatively high effort. The accuracy of alignment was mainly determined by the number of turns from the user and appeared to be relatively good.</p>

Assessor signature	Date
<i>Assessor 1</i>	03/04/2022

Commentary

Testing was carried out against some of the design criteria – maximum effort was not checked, and recyclability and use of standard parts are statements without supporting test evidence, such as checking materials certificates or reference to standard sizes available. Of the criteria evaluated, the prototype met the requirements.

The candidate selected some appropriate objective tests, such as the use of the meter rule for measurement and the silk test, to check that some features met the design criteria. Functional testing was used appropriately and to scale, to evaluate some of the main performance aspects in the design criteria. Some of the criteria were assessed functionally, such as the turning effort, where an objective test would have been more appropriate as the testing may be inaccurate. Whilst the approximate measurements of sizes were appropriate, the snags during the silk test indicate that the test may not have been interpreted accurately.

The candidate completed a test record of the activity and their findings. The record lists all aspects of the criteria, including some that were not tested, and is basic with minimal use of technical explanation, although it contains most of the appropriate information. To develop their response, the candidate could have added more detail about how they calculated the parameters for the scaled down model. They could also have added more depth to the methods used and results of each test undertaken and ensured that all the results and measurements were accurate.

Task 3 – Peer review

(Assessment themes: Reports)

For task 3, candidates need to produce the following pieces of evidence:

- candidate notes on the candidate feedback record form

The candidate notes are not included in this document as the notes will vary from candidate to candidate and are not used to inform any other task.

- peer review feedback form.

This is supporting evidence for assessors to see what feedback the candidate received and how they used it in their review for task 4, and will not be marked.

Peer review feedback form

Candidate name	Candidate number
Candidate B	CG01234
Centre name	Centre number
City & Guilds	12345

Question	Feedback
How well does the design meet the requirements in the brief?	<i>I think the design is generally good. It meets most of the requirements of the brief. It can raise the box at the required height and should be able to support the weight. The runner rails are a good idea, as these would stop the lifting platform moving too far.</i>
How appropriate is the equipment proposed for the design?	<i>The equipment used seems to be generally appropriate. I don't like that the height of the handle moves up and down with the lift, as that means the user has to bend over to use it, especially when it is close to the floor. Older workers might get a bad back from bending over a lot. Also a wheel might be easier for a worker to turn than a handle.</i>
What are the implications to the business of the proposed design?	<i>It takes a while to raise and lift each box, so it might mean that less stuff gets done in the stores. But it should also mean less effort is needed for manual lifting, which means less risk of injury and time off for people who work in the stores.</i>
How can the design be optimised/improved?	<i>I think you should include a larger threaded bar with a coarser thread leading to fewer turns of the handle, which would make it easier for the operator to use.</i>

Peer review feedback form

Candidate name	Candidate number
Candidate B	CG012345
Centre name	Centre number
City & Guilds	12345

Question	Feedback
How well does the design meet the requirements in the brief?	<i>This is a good design overall. It lines up well with the shelf at ground level and the packing table at the higher level. I think that there needs to be a cover over the arms of the lift, as someone could put something between the arms as it is closed. That could just be a clear sheet to act as a guard.</i>
How appropriate is the equipment proposed for the design?	<i>The equipment used seems to be generally appropriate. Maybe it could be improved a bit by making it easier to push the box onto and off the platform. That could be done by having a slippery coating on the platform or by using rollers built into the platform. That would reduce the effort needed by the operator, so they wouldn't get as tired over the movement if they have to use this a lot.</i>
What are the implications to the business of the proposed design?	<i>It should make lifting things in the stores a lot easier. It will take longer to lift using the device than just lifting by hand, but because it is easier this probably means that workers can lift more over the shift. There would also be less risk of getting a bad back due to manual lifting, so workers might have less time off injured.</i>
How can the design be optimised/improved?	<i>As above, put a cover or guard in front of the lifting arms and make the surface of the lifting platform more slippery using a coating or rollers.</i>

Task 4 – Evaluation and implementation

(Assessment themes: Health and safety, Design and planning, Reports)

For task 4, candidates need to produce the following pieces of evidence:

- a) outcomes of virtual modelling
- b) revision control document
- c) evaluation and implementation report.

4a) Outcomes of virtual modelling

Candidate evidence

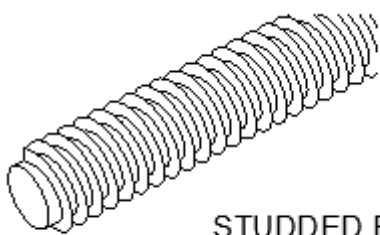
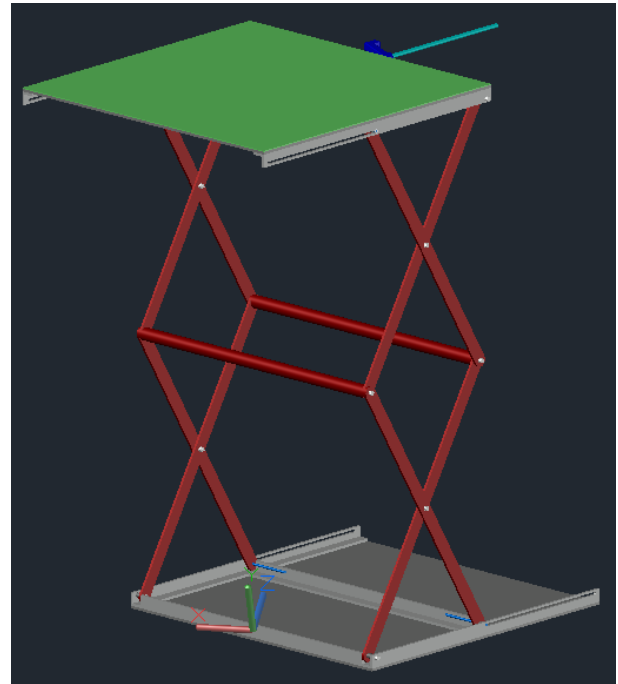
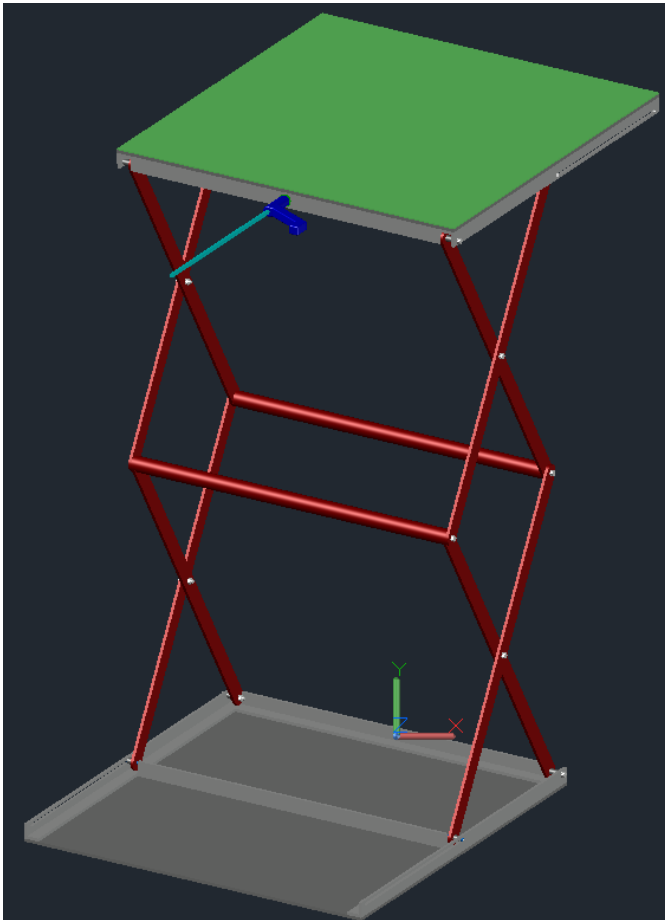

STUDED BAR DETAIL
M10 COARSE THREAD

Commentary

The candidate has updated their original virtual design from task 1 to incorporate the changes they decided on, namely a larger threaded bar with a coarser thread for the handle and the addition of a sheet of nylon on top of the lifting platform to reduce friction and therefore effort required to push boxes onto it.

The nylon sheet is visible as green on the top plate of the platform. The candidate has included detail of the studded bar with the M10 coarse thread, but there is no annotation to point where exactly this would be placed on the platform.

To improve, the candidate could have included detail of the exact position of the threaded bar using annotations and provide some more detail of the way the nylon sheet is fitted onto the top plate of the platform.

4b) Revision control document

System type	Manually-powered mechanical lifting device
System TAG number	A1B2C3
Department responsible for equipment	Design and Development department
System designed by:	Candidate A

Design description:

This is a device to lift boxes that arrive at ground level on a picking shelf to a height of one meter, so they can be pushed onto a packing table in the opposite direction. The boxes are cuboid in shape with a maximum side of 500 mm and a maximum weight of 15 kg. The boxes are moved off and pushed onto the packing table manually by the user. The device uses a screw mechanism which is located inside the top bed and connected to the lift arms. The user manually turns the handle to raise and lower the lifting platform, to the height and position needed. The use of a screw type of mechanism gives a big mechanical advantage, as much less effort is needed to lift the boxes than would be the case if they were lifting them by hand.

Changes to existing system:

Candidate B suggested using a larger threaded bar with coarse thread to make it easier to operate, thus creating less turns of the handle.

Candidate C suggested adding a sheet of material in front of the lift arms so that no one could get fingers or clothes trapped in the mechanism when it closes down. In effect this is a guard, using a material like latex sheeting which will move freely with the lift is the most effective as a polycarbonate sheet would make the lift cumbersome. This is a good idea in principle, but in the closed position, a latex sheet will all gather up in a bundle, so I will not go ahead with this addition at this stage. This is something to consider for a possible redevelopment.

This change would improve the design. I would also put a sheet of nylon on top of the lifting platform as it was difficult to push the box on and push the box back onto the table.

Changes to existing technical documentation:

The main changes that need to be made to the engineering drawings are:

There needs to be extra drawings for the threaded bar and nylon sheet, which is just a rectangular piece of material. The general arrangement drawing needs to be changed with these added.

The standard operating procedure (SOP) for making the nylon sheet would need to be written.

The bill of materials also needs to be changed to add the threaded bar and nylon sheet.

The design criteria and specification do not need to be changed, but with the changes the new design meets them better.

Comments:

Overall, I am happy with the feedback received and have acted on the main points given by each candidate as they improve the design. I have suggested changes based on these that would help my design to meet the criteria more fully.

Validation performed by:	<i>Assessor 1</i>
Prototype approved by:	<i>Assessor 1</i>
Date:	16/06/2022

Commentary

The candidate has read and taken into account the feedback from both peer reviewers. They have identified three changes to the design that are suitable. They have given very basic statements to support two of these changes ('to make it easier to operate' and 'so that no one could get trapped in the lifting arms of the mechanism') but have not justified why the sheet of nylon was added to the top of the lifting platform.

To develop their response further, they could have added more detail to the changes, such as the dimensions of the parts and how the nylon sheet would be attached to the top platform. They could also have considered alternative options for each change, such as alternate designs or materials. They should ensure that reasons are given for all changes and added more detail to the reasons for the changes, for example quantifying the reduction of force for pushing the box off the lifting platform. Adding this would have shown greater technical understanding of the feedback made and its implications.

The candidate has produced a revision control document that covers the main requirements and documentation that would need to be updated. They have correctly identified the drawings and documents that would need to be changed or produced. To develop their response, they could have explained how and why this needs to happen in more depth. For example, why this is important and suggested appropriate version numbers to use.

4c) Evaluation and implementation report

Evaluation –

Before manufacturing the prototype, I did some design calculations to ensure that it met the requirements of the brief for the mechanical advantage. I made a virtual model to ensure that the parts fitted together correctly and to simulate the loading, to give confidence that it would be able to do the task.

I mostly used scaled down functional testing to evaluate the operation of my prototype, as this gives the best indication of how well it will work when it is used by workers in the stores environment.

This involved setting up the lifting device in a simulated store area with a picking shelf and a packing table at the correct height and moving a box of the biggest possible size and weight, which was supplied by my college. I positioned the lifting platform slightly below the entry picking shelf as this made it easier to push the box onto the platform. It still required some effort as it didn't slide easily over the surface. Then I turned the handle to raise the box until it was slightly above the exit roller table. This took about 40 turns but was fairly easy as it didn't need much effort, but this was a lot of turns. I did have to bend down to turn the handle, as the handle went up and down as the lift operated. I then pushed the box onto the packing table and wound the handle the other way to lower the lifting platform back to the starting position, ready for another box.

Before the functional test, I measured the main dimensions of the lifting platform with a metre rule to make sure that the box would fit and checked that there were no sharp edges using a silk test, so there would be no risk of cutting fingers.

The testing showed that I met most of the requirements of the design specification, such as the sizes and achieving the pick-up and drop-off positions. Although I could not measure the efficiency of lifting, the force needed to do the lift didn't require much effort. Using typical figures for a scissor lift and a 200 mm handle, I calculated:

$$\text{Mechanical advantage} = (\text{load} \times \text{pitch} / \text{typical efficiency}) / (2\pi \times \text{handle length}) / \text{applied force} = 441 / ((147 \times 1.5)/1.16) / (2\pi \times 200) = 15.1$$

Overall the prototype worked well, but there are two improvements to make, the first of which came from the peer feedback:

- Candidate B suggested using a larger threaded bar with coarse thread to make it easier to operate, thus creating fewer turns of the handle.
- Put a sheet of nylon on top of the lifting platform to make the surface more slippery so it is easier to slide the box on to and off the lifting platform.

These will improve how well the design meets the design specification as the user will not have to move so much or bend over reducing the risk of repetitive strain injury and there will be less risk of the user getting trapped in the lifting mechanism.

Implementation –

In order for a third party to implement the prototype they will need the following information and documentation:

- The initial design criteria from the brief and final design specification from task 1.
- The bill of material from task 1.
- The engineering drawings for each of the individual components from task 1.
- The general assembly drawing from task 1.
- The risk assessments from task 2.

- Standard operating procedures (SOPs) or a production plan for making and assembling the parts.

It might also help if they have a copy of the virtual model so they can see what the assembled device looks like.

The main health and safety considerations for the manufacturing were the use of personal protective equipment (PPE) such as safety glasses and appropriate gloves (for handling the cut parts, except when using the lathe, where gloves would increase the risk of injury) and wearing overalls, with boots. All workers should be trained to use the processes correctly, tie back any loose clothing and hair, follow the SOPs and all the machines should be well maintained.

Commentary

The candidate has produced an evaluation and implementation report that contains some basic information relevant to the design and finished prototype.

They have explained the test methods used and provided brief justifications for their use. They have also explained how their prototype meets some of the needs of the design criteria and described the improvements that need to be made to better the design brief. They have identified three improvements with some supporting justification for the first two of these. These changes are suitable and would be beneficial to the design. To develop further they could have justified the improvements needed in greater detail, giving details such as the method of fixing the nylon sheet on the top platform.

The candidate included a calculation of the mechanical advantage to illustrate the operating efficiency of the device, although this drew on some typical data so may not be accurate. Health and safety considerations were covered for both the design improvements and outlined in brief for the manufacturing implementation.

The candidate has provided a list of documentation relevant to implementation, indicating that they have some knowledge of their relevance and importance. However, their response could have been developed further with more detail provided on the reason why each document is required for a third party to implement the manufacture and the information within each document that is of particular relevance.

The T Level is a qualification approved and managed by the Institute for Apprenticeships and Technical Education.

Copyright in this document belongs to, and is used under licence from, the Institute for Apprenticeships and Technical Education, © 2020. 'T-LEVELS' is a registered trademark of the Department for Education. 'T Level' is a registered trademark of the Institute for Apprenticeships and Technical Education. 'Institute for Apprenticeships & Technical Education' and logo are registered trademarks of the Institute for Apprenticeships and Technical Education.

We make every effort to ensure that the information contained in this publication is true and correct at the time of going to press. However, City & Guilds' products and services are subject to continuous development and improvement, and the right is reserved to change products and services from time to time. City & Guilds cannot accept responsibility for any loss or damage arising from the use of information in this publication.

City & Guilds Limited (Reg No 16513878). All rights reserved. City & Guilds is a trademark of City & Guilds Limited. City and Guilds Group Giltspur House, 5–6 Giltspur Street London EC1A 9DE