



HM Government

T-LEVELS

**T Level Technical Qualification in
Design and Development for
Engineering and Manufacturing
(8714-31)**

**Occupational Specialism in
Mechanical Engineering
(321)**

**Guide Standard Exemplification Material
Distinction**



First teaching from September 2022

Version 1.2

Version and date	Change detail	Section
1.1 January 2023	Formatting of Task 1 evidence requirements	Task 1
1.2 March 2026	Minor amendment to first paragraph	Introduction

Contents

Introduction	3
Grade descriptors	4
Task 1 – Design	5
1a) <i>Design specification</i>	5
1b) <i>Annotated sketches</i>	9
1c) <i>Justification of the choice of one design for further development.....</i>	13
1d) <i>Justification of the selection of the materials and components</i>	15
1e) <i>Design calculations</i>	19
1f) <i>Engineering drawings</i>	21
1g) <i>Outcomes of the virtual modelling of the proposed design.....</i>	24
1h) <i>Bill of materials.....</i>	27
Task 2 – Manufacture and test.....	29
2a) <i>Risk assessment.....</i>	30
2b) <i>Manufacture of the prototype.....</i>	32
2c) <i>Testing.....</i>	40
Task 3 – Peer review	44
<i>Peer review feedback form</i>	45
Task 4 – Evaluation and implementation.....	46
4a) <i>Outcomes of virtual modelling.....</i>	47
4b) <i>Revision control document.....</i>	49
4c) <i>Evaluation and implementation report</i>	51

Introduction

The Guide Standard Exemplification Material within this document refer to the T Level Technical Qualification in Design and Development for Engineering and Manufacturing - Occupational Specialism in Mechanical Engineering sample assignment. The aim of these materials is to provide centres with examples of knowledge, skills and understanding that attest as examples of a distinction grade. In this document all exemplar evidence attests as examples of performance at the distinction grade boundary. The examples provided do not reflect all evidence from the sample assignment as the focus of this material is the quality and standards that need to be achieved rather than the volume of exemplar evidence provided. However, the examples provided are representative of all tasks in the sample assignment. The evidence presented here has been developed to reflect a distinction grade within each task but is not necessarily intended to reflect the work of a single candidate. It is important to note that in live assessments a candidate's performance is very likely to exhibit a spikey profile and the standard of performance will vary across tasks. A distinction grade will be based on a synoptic mark across all tasks.

The materials in this Guide Standard Exemplification Material (GSEM) are separated into three sections as described below. Materials are presented against a number of tasks from the assignment.

Task

This section details the tasks that the candidate has been asked to carry out, what needs to be submitted for marking and any additional evidence required including any photographic evidence. Also referenced in this section are the assessment themes the candidates will be marked against when completing the tasks within it. In addition, candidate evidence that has been included or not been included in this GSEM has been identified within this section.

In this GSEM there is candidate evidence from:

Task 1

Task 2

Task 3

Task 4

Candidate evidence

This section includes exemplars of candidate work, photographs of the work in production (or completed) and practical observation records of the assessment completed by centre assessors. This will be exemplar evidence that was captured as part of the assessment and then internally marked by the centre assessor.

Commentary

This section includes detailed comments to demonstrate how the candidate evidence attests to the standard of minimal threshold competence by directly correlating to the grade descriptors for this occupational area. Centres can compare the evidence against the performance indicators in the marking grid descriptors within the assessor packs, to provide guidance on the standard of knowledge, skills and understanding that need to be met for minimal threshold competence.

It is important to note that the commentary section is not part of the evidence or assessment but are evaluative statements on how and why that piece of evidence meets a particular standard.

Grade descriptors

To achieve a distinction, a candidate will typically be able to:

Demonstrate a comprehensive use of software/ technologies to model, evaluate and produce mechanical engineering diagrams and simulations that meets the requirements of the brief.

Demonstrate excellent technical skills when developing models and prototypes, resulting in a model that is fully functional.

Apply comprehensive knowledge and understanding of testing processes, resulting in a model that has been tested against all of the design criteria.

Critically interpret information to plan, assess risk, follow safe working practices and apply the technical skills to practical tasks and procedures to an exemplary standard in response to the requirements of the brief, producing an excellent quality of work.

Apply comprehensive knowledge and understanding of the design principles required for mechanical engineering resulting in proposals and solutions that meet all requirements of the brief.

Work safely and make well founded and informed decisions on the selection and appropriate use of tools, materials, and equipment within the environments that they are working in, resulting in tasks that are carried out to a high degree of accuracy.

Use accurate industry and technical terminology consistently in both written and verbal contexts.

Task 1 – Design

(Assessment themes: Health and safety, Design and planning, Manufacturing, Reports)

For task 1, candidates need to produce the following pieces of evidence:

- a) design specification
- b) up to three annotated sketches
- c) justification of the choice of one design for further development
- d) justification of the selection of the materials and components
- e) design calculations, including all workings
- f) engineering drawings of the proposed design
- g) outcomes of the virtual modelling of the proposed design, either as screen captures or printouts
- h) bill of materials.

For Task 1, the following additional evidence may also be submitted:

- any notes produced of research undertaken including citation of sources and internet search history.

1a) Design specification

Candidate evidence

Requirements from design criteria:

- The lifting device must be manually powered.
- It must reduce the effort required by workers to raise the load.
- It must be capable of lifting a cuboid box of maximum mass 15 kg.
- It must be capable of lifting a cuboid box of maximum width, depth, and height each 500 mm.
- It must be capable of lifting the load from 100 mm above ground level to a height of 1 m and returning to its start position.
- The lifting platform must allow a human worker to push the box off onto a packing table.
- The lifting activity must be carried out safely.

Design specification:

Building on the requirements of the design brief, I have created the following design specification:

	Design Criteria	Reason
1.	The minimum size of the lifting platform must be at least 600 × 600 mm	To accommodate inaccurate loading when the box is pushed onto it, and also to allow the mechanism to travel to the required height.
2.	The device must be capable of lifting 147 N	Requirement of the design brief, including both the box and the lifting platform. [See design calculations for justification]
3.	The maximum effort required to raise the load should be 107 N	Based on the ergonomic tables as this is the maximum sustainable force by an adult. [See design calculations for justification]
4.	The device should give a mechanical advantage of at least 2.2 to lift the maximum load	Based on maximum effort with a lever that can be applied by an adult from the ergonomic tables. [See design calculations for justification]
5.	The device must be capable of lifting the load from 100 mm above ground level to a height of 1 m to allow the boxes to be loaded/unloaded	Requirement of the design brief, so that it aligns with the picking shelf and the packing table.
6.	The device must be able to return to its start position	Requirement of the brief. Facilitates moving more than one box before the device is moved.
7.	The mechanism should be operated by a lever	From the ergonomic tables the user can apply a higher force to a lever than a wheel control,

		so if they are moving the same load the lever would feel easier.
8.	The lever must be positioned at a height between 0.5 and 1.5 m	I believe that this is a convenient height for the operator, to avoid repetitive strain injuries from bending or over extended reaching.
9.	The device must weigh less than 15 kg	So that it can be moved by one operator (as safe lifting regulations specify 15 kg as the maximum).
10.	The lifting platform should be manufactured from aluminium	If steel is used the weight of the lifting platform alone would be approximately 12.15 kg, before any other parts were added, so requirement 9 would probably not be met. Aluminium will still give the required strength but is far more lightweight. It would also be resistant to the knocks and minor impacts that could be experienced in a stores environment, particularly when being moved. [See design calculations for justification]
11.	The lifting platform should have a surface with low friction	To reduce the effort required by the operator to push the box into place. Friction would result in resistance to the movement and potentially generate too much heat.
12.	The platform must have no sharp edges	To reduce the risk of injury (cut fingers, skin etc) to the users and their colleagues when operating or working near to it.
13.	Any parts that move or rotate must be guarded or covered	To reduce the risk of injury (such as finger traps, entanglement etc) to the users and anybody else working nearby. Entanglement in moving parts can result in very serious injuries inclining potential loss of limbs. The device would not meet relevant health and safety standard if not appropriately guarded.
14.	At least 70% by weight of the materials used in the device should be recycled or recyclable	To minimise impact on the environment and reduce the overall carbon footprint of the product. Using recycled and/or recyclable materials would also reduce the transportation costs of new materials.
15.	The device should be made from standard-sized forms of material	To minimise costs for obtaining or manufacturing special parts or modifying parts.

Commentary

The candidate has produced a detailed design specification in response to the task that shows clear consideration of the design requirements by contextualising these into clear and justifiable design criteria. The design criteria have been clearly structured and articulated to ensure the brief is met. Clear supporting rationale has been provided for all of the factors, including those related to the design itself, as well as additional factors such as sustainability and the form of the materials used.

Specification is detailed and thorough with accurate technical knowledge throughout. Accurate technical knowledge has been shown throughout the specification, with references to the calculations later on that provide additional justifications.

All points have been analysed and elaborated on with appropriate justifications and reasons. For example, resulting in the specification of aluminium for the lifting plate to meet the requirements of the criteria for weight and justifying the need to use a high percentage of recycled or recyclable materials.

1b) Annotated sketches

Candidate evidence

Sketch 1a

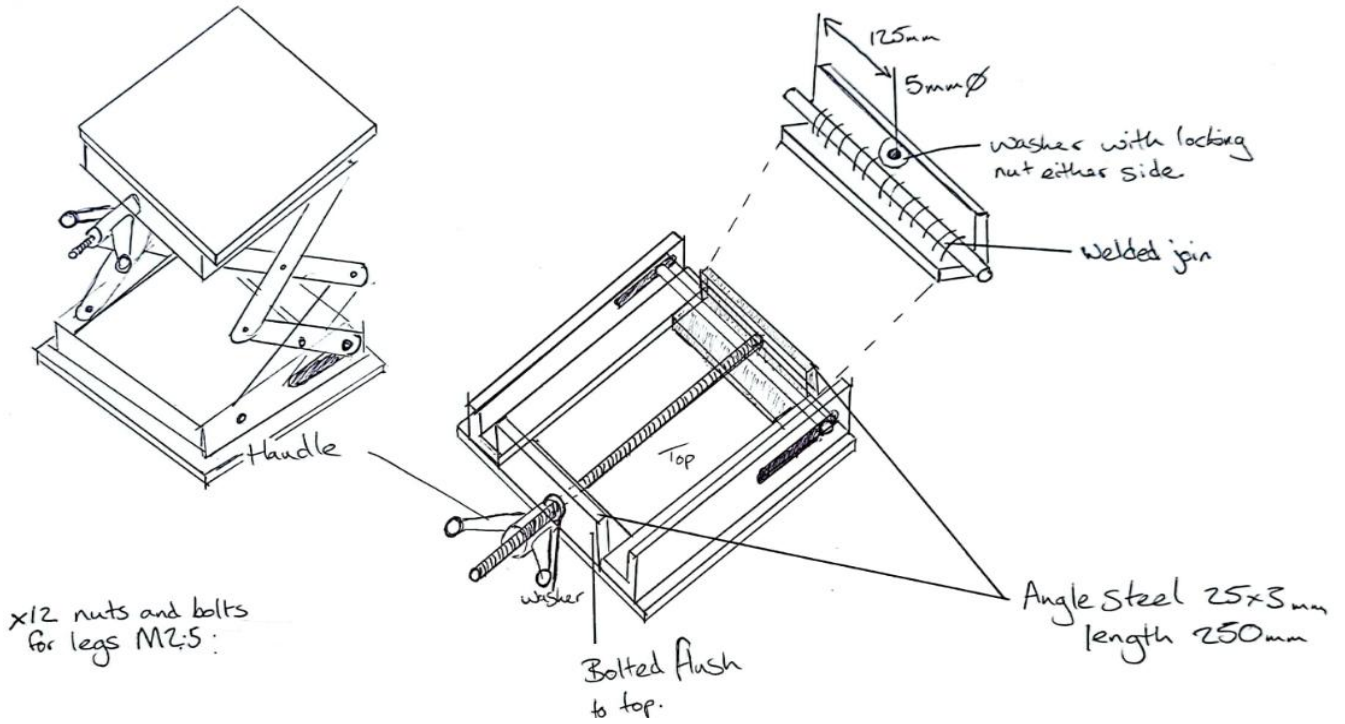

Sketch 1b

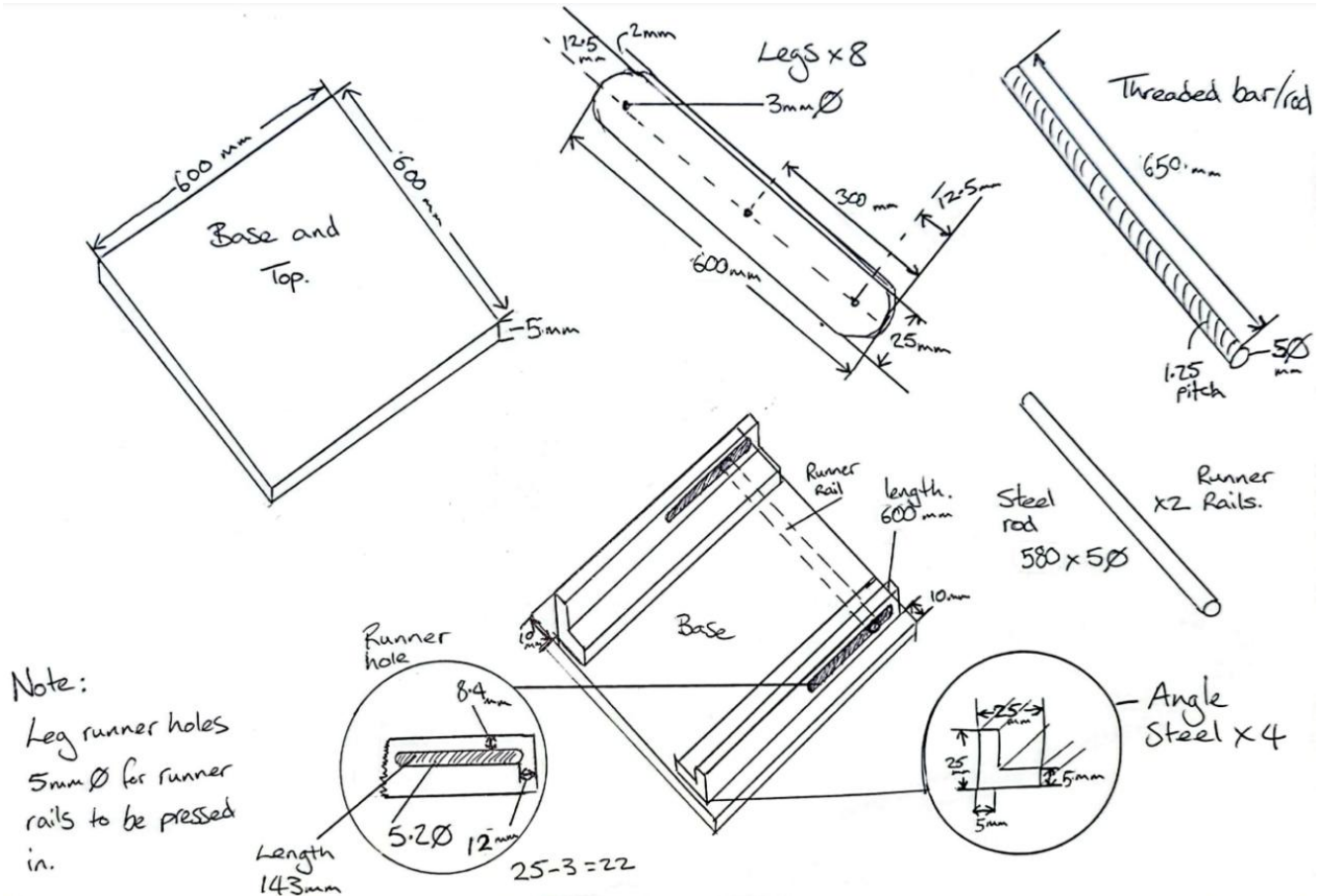

Sketch 2a

Page 1

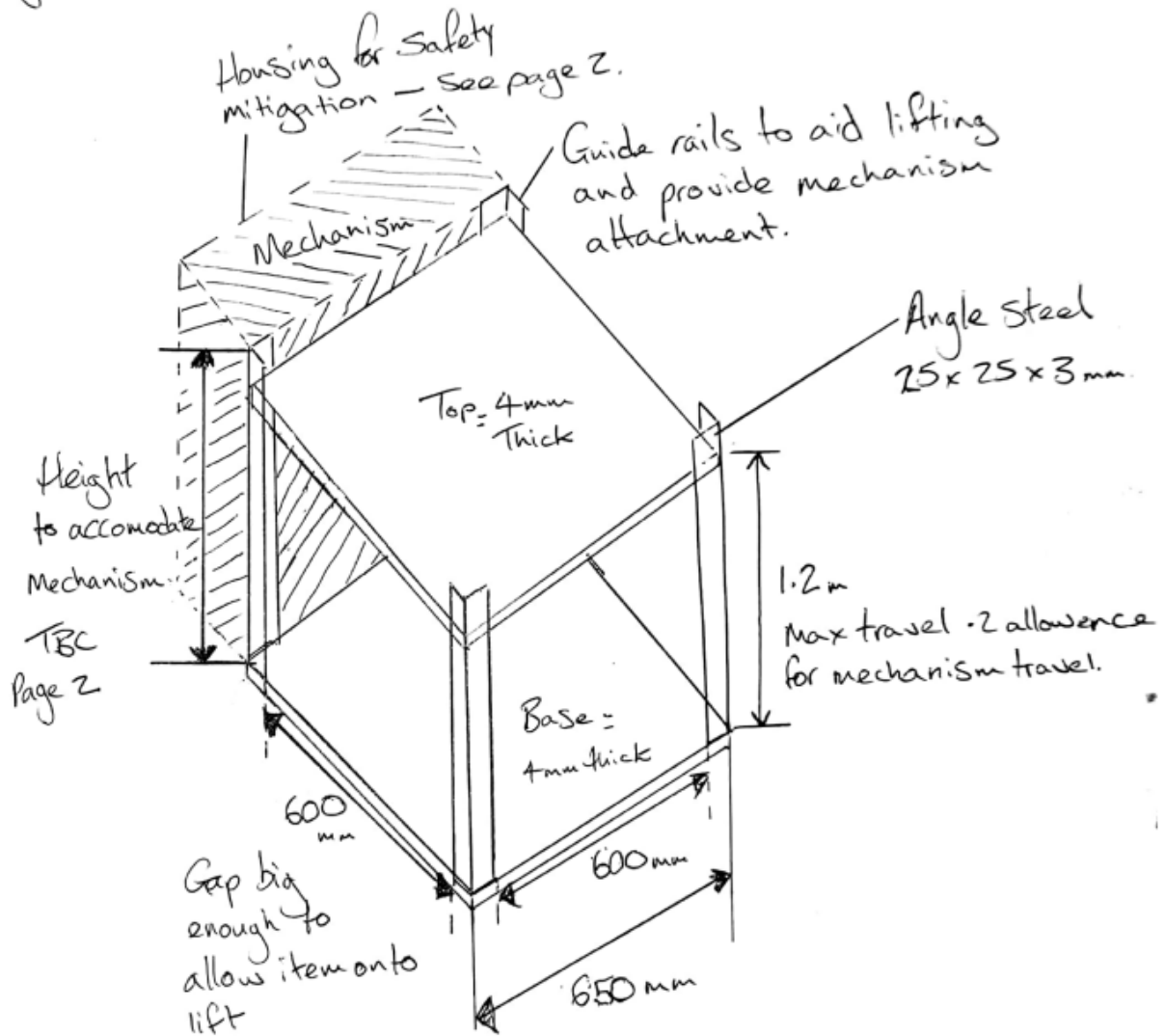

This drawing shows a general design where different lifting mechanisms can be allocated outside of the lift with a cover to prevent entrapment and injury.

Sketch 2b

Page 2

Mechanisms

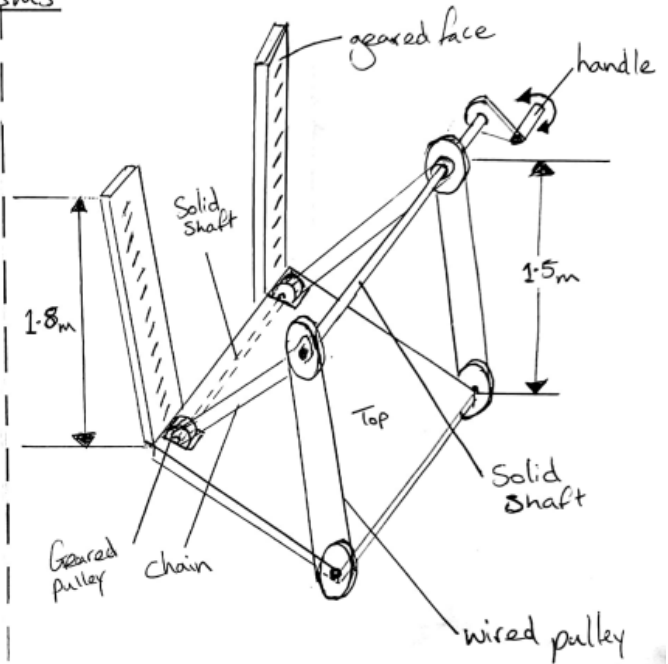
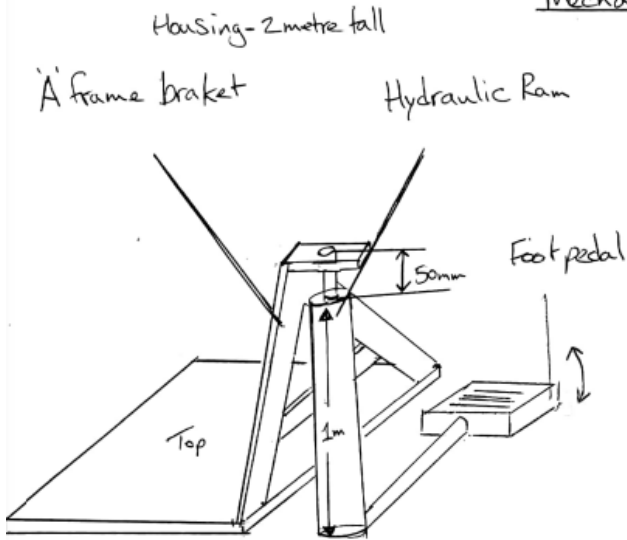

A frame dimensions

30mm wide
 4mm thick

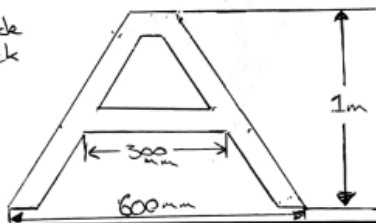

This requires housing all around with sufficient clearance.

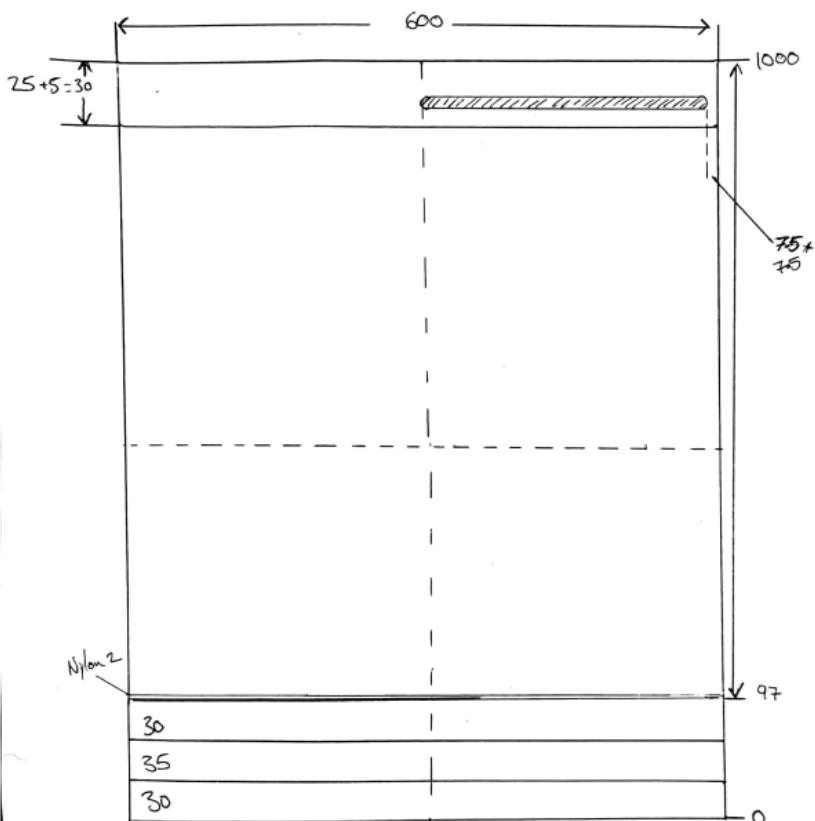

Rod board drawn for calculations and practical application.

The hydraulic ram would require to be mounted on a plate – extending the base of the lift. An ‘A’ frame is used to distribute the weight. A foot pedal and use of hydraulics reduces the required effort on the operator. Using pulleys seems to take up lots of space surrounding the lift and the gearing would be exposed and requires cover. Effort can be reduced by using gear reduction calculations, however this design of mechanism I feel uses up too much space. Pulleys have (mechanical advantage) $MA = 4$

All sketches do not show in detail a nylon sheet top, this would be used to reduce operator/human effort due to friction. Therefore, a **note** is that whatever design I finally use it must have a nylon or polycarbonate sheet attached to the top surface of the lift.

Commentary

The candidate has demonstrated the ability to design a number of detailed options that have been visually presented through different sketches.

The sketches are clear, and the supporting annotations contain most of the information that a third party would need to reproduce them, for example the use of bolts to create hinges for the lifting legs in sketch 1.

There is detail in the drawing, such as the use of angled steel, offset of the hydraulic ram so that the platform can go low enough and supported by the design calculations, which demonstrates design decisions arising from development in design thinking. However, although there is a detailed sketch of the lifting arm in sketch 2b there is limited detail as to the dimensions or shape of this beyond the bends, which would make reproduction of that component difficult.

Several annotations refer explicitly to the specification points, demonstrating excellent understanding of how the proposed solutions could meet the requirements. This also shows coherence between the intended design brief and the design solutions presented. Annotations also identify some of the manufacturing processes required, reinforcing the demonstration of understanding, as well as additional annotations such as the specific measurements of the materials.

1c) Justification of the choice of one design for further development

Candidate evidence

I have compared my design ideas to the design specification:

No.	Comments
1, 2, 5 & 6	Both designs have a lifting platform, which should accommodate the size and weight of the boxes, the required load, the loading and lifting heights and be able to reset to the start position.
3 & 4	All design options should meet this requirement. The pulley system (sketch 2b) has a mechanical advantage of 4, whereas both the other designs should have mechanical advantages of over 100 due to the use of leverage, meaning that they would require substantially less effort.
7 & 8	Sketch 1a could have a crank lever added, although it would operate without this so that would just add extra weight. In sketch 2b there are levers which could be located within the range specified. Sketch 1b has the advantage that the lever is in a fixed position whereas in sketch 1a the lever position will move within the range.
9	Based on the design calculations, both designs could potentially weight under 15 kg. However, to meet the guarding requirements an additional structure may be required for sketch 1a to cover the pulleys, which could increase the weight over the target value.
10, 11 & 15	All designs have an aluminium lifting platform and surfaces that have low friction, by use of a nylon surface (noted in the commentary). They could also all be made with standard sizes and forms of material.
12 & 13	As above, sketch 1b may need an additional structure to provide guarding to the moving parts. Sketch 1a would need a material cover attached to the outside of the scissor-mechanism, such as linen or nylon covered material. All designs should be able to be produced without sharp edges.
14	All designs are mainly made using aluminium or steel, both of which are recyclable. The pulleys and rope in sketch 2b would be a small proportion of the weight, but relative to sketches 1a and 2a would have a higher proportion of material that may not be recyclable. Sketch 2b may require hydraulic oil, which cannot be recycled.

My sketches lead me to think that the material of choice is steel, after evaluation I believe the use of Aluminium for the main structure and steel for the mechanism is better for weight consideration's to be met.

Although all designs could meet all of the specification requirements, my design shown in sketch 2 will not be progressed as the designs shown in sketch 1 better satisfy specification points 4, 7, 9, 13 and 14. Sketch 2b (mechanism 1) has the advantage of a fixed lever position (spec. point 8), but the hydraulic ram weighs more than the entire lift (spec. point 9) and would require hydraulic oil which means less by-weight of the mechanism could be recycled (spec. point 14). So, on balance I have decided to develop the design shown in sketch 1.

Commentary

Overall this is a very good evaluation. The candidate has used their design criteria in order to determine the design solution to progress. The candidate has effectively compared all three designs (2 mechanisms in sketch 2b making three potential designs) to the design criteria in the specification, highlighting most of their relative advantages and limitations. For example, when considering the mechanical advantages of each design, they have compared the pulley system shown in sketch 2b with the more effective designs in relation to this shown in sketches 1a and 1b.

The justifications provided are correct and relevant to the original design and there is specific reference to individual requirements of the brief. There is clear and detailed reasoning shown to justify decisions made regarding the selection of a final design to take forward and develop.

1d) Justification of the selection of the materials and components

Candidate evidence

Material	Stainless steel
Properties	Resistance to corrosion Tensile strength 500-700 MPa Tough Good hardness 215 max HB Durable Resistance to temperature
Where this would be used	Runner rails, handle, mechanism and fixings.
Form of supply	Sheet and bar / rod (including threaded).
Ease of manufacture	Hardness means it can be difficult to cut and drill, taking more time and wearing out tools more quickly. Relatively straightforward to weld. Sheets can be bent using standard workshop equipment, although difficult due to high strength.
Material positives	5 mm diameter bar would be able to support tensile strength = $600 \text{ MPa} (\pi \times r^2 \times \text{tensile strength} =) 4750$, substantially more than the load in spec. point 2, so would not distort during use. To support the maximum load of 147 N from spec. point 2 cross sectional area needed would be $< 1 \text{ mm}^2$, so in practice limited only by available forms. Durable and tough – would resist minor knocks and impacts in the stores and when moved. Good hardness, so resistant to wear and tear. Would not need painting due to corrosion resistance.
Material negatives	Costs 100-200% more than mild steel, but still less expensive than aluminium alloys. High density (approximately 8 g/cm^3), which would mean that it could be quite heavy and difficult to move around. Cannot be easily welded to aluminium.

Material	Mild steel
Properties	Tensile strength 400 MPa High toughness Good hardness 130 HB Good weldability Prone to oxidation / rusting
Where this would be used	Runner rails, handle, legs and mechanism.
Form of supply	Sheet and bar / rod (including threaded).
Ease of manufacture	Easier to cut and drill than stainless steel, as not as hard.

	<p>Easier to weld than stainless – could use TIG or MIG processes to join parts together.</p> <p>Slightly easier to bend sheets using standard workshop equipment than for stainless steel due to lower tensile strength, but more difficult than for aluminium.</p>
Material positives	<p>5 mm diameter runner rail would be able to support ($\pi \times r^2 \times \text{tensile strength} =$) 3166 kN, substantially more than the load in spec. point 2, so would not distort during use. To support the maximum load of 147 N from spec. point 2 cross sectional area needed would also be $< 1\text{mm}^2$, so in practice limited only by available forms.</p> <p>Relatively cheap compared to most metals and readily available in a wide range of standard sizes.</p>
Material negatives	<p>Rusts – needs painting or coating, which could be damaged / chipped in a store environment.</p> <p>Density approximately 7850 kg/m^3 slightly less than stainless but it could still be quite heavy and difficult to move around.</p> <p>Cannot be easily welded to aluminium.</p>

Material	Aluminium alloy
Properties	<p>Low density</p> <p>Tensile strength 90 MPa</p> <p>Fair hardness 34 HB</p> <p>Ductile</p> <p>Good toughness</p> <p>Excellent corrosion resistance</p>
Where this would be used	Base and lifting platform, runner rails, handle.
Form of supply	Sheet and bar / rod (including threaded).
Ease of manufacture	<p>Easier to machine than the ferrous metals due to lower hardness.</p> <p>Can be difficult to weld. – would need to use the TIG process.</p> <p>Easier to fabricate sheets into required forms using standard workshop equipment than for ferrous metals due to higher ductility and lower strength.</p>
Material positives	<p>5 mm diameter runner rails would be able to support ($\pi \times r^2 \times \text{tensile strength} =$) 712 kN, still more than 25 times the load in spec. point 2, so would not distort during use. To support the maximum load of 147 N from spec. point 2 cross sectional area needed would also be $< 4\text{mm}^2$, so in practice limited only by available forms.</p> <p>Lower density than either ferrous metal, so the weight of the device for a comparable design would be approximately 1/3 the weight if a ferrous metal was used.</p> <p>Good toughness so resistant to general knocks and would not need painting due to corrosion resistance.</p> <p>Ductility means it would be easier to form than ferrous metal options.</p>
Material negatives	<p>30-60% more expensive than stainless steel and 200-300% more than the cost of mild steel (although labour time would be saved during manufacture).</p> <p>Can be more challenging to achieve a strong weld, and would need to use the TIG welding process to join parts together, which requires higher skill than MIG welding.</p>

Material	Brass
Properties	Moderate strength Corrosion resistance Aesthetically pleasing appearance Self-lubricating properties
Where this would be used	Runner rails, handle.
Form of supply	Bar and rod.
Ease of manufacture	Easier to cut, mill, drill and turn than aluminium alloy. Can be difficult to weld – would need to use the TIG process.
Material positives	Good aesthetic appearance. Corrosion resistant, so the lifting device would not need to have an applied finish. Easy to turn compared to other metals.
Material negatives	Relatively expensive compared to both aluminium alloys and stainless steel. High density (8730 kg/m ³) so would add more to the weight of the device than other metals.

Material	Nylon
Properties	Light weight Self-lubricating surface Good wear resistance
Where this would be used	Surface sheet on lifting platform.
Form of supply	Sheet.
Ease of manufacture	Easy to cut.
Material positives	Light weight. Low friction surface.
Material negatives	May not be easy to recycle.

Considering the above, I will use aluminium for the base, top, lifting arms and runner rails, as this has strength substantially above the requirement for the load in the specification, so would be able to lift the boxes without bending whilst giving the overall weight of the device approximately 1/3 of that using either mild steel or stainless steel. It has good toughness so would be resistant to knocks and minor impacts which can occur in the stores area. It is available in a broad range of standard sizes and although it costs more than either of the ferrous metals, it would be easier to manufacture due to its lower relative strength and ductility, which would reduce the time and labour cost during manufacturing. It would not need to be painted, which would further save manufacturing cost and time compared to mild steel. For the handle I will use brass, as this is relatively easy to turn and aesthetically pleasing.

I would also need a threaded bar M5 × 1.25, M3 × 5 bolts and M3 nyloc nuts. These would be made from stainless steel due to commercial availability and properties of this metal.

Commentary

The candidate has provided a detailed overview of the materials and components that are needed for the design. An advanced level of knowledge and understanding is demonstrated for the different materials that have been identified (which include ferrous metals, non-ferrous metals and polymers), with decisions based on values of properties, calculations (for example, the ability to support the load) and comparisons drawn between the different materials (for example, the relative weight and the corrosion resistance).

The candidate has provided detailed reasoning for most of the material choices. The reasoning and justification are clear and consider the context in which each part will be used and the manufacturing requirements. For example, the risk of minor impacts in a stores area. The candidate has weighed up both positive and negative points for each material and drawn comparison with the feasible alternatives in order to support their justifications.

1e) Design calculations

Candidate evidence

Mass of the lifting plate

Volume of the lifting plate = $l \times w \times h = 61 \times 61 \times 6 = 22.326 \text{ cm}^3$

Based on density of 2.7 g cm^{-3} for Al, the mass would be 4.214 kg

Based on density of 7.85 g cm^{-3} for steel, the mass would be 12.15 kg

Based on density of 0.09 g cm^{-3} for nylon, the mass of a sheet on top of the aluminium of $60 \times 60 \times 0.2 \text{ cm} = 720$ would be $720/0.09 = 8000/1000 = 8 \text{ g}$

Mechanical advantage

From ergonomic tables at <https://ergoweb.com/force-guidelines/>:

Maximum manual lever force that can be applied = 29 lbs = 13kg = 127.5 N

Maximum two-handed push pull force that can be sustained = 24 lbs = 10.8 kg (rounding down to avoid exceeding the maximum) = 105.9 N

Maximum load from box and lifting platform = $mg = (15 + (4.214 + 0.048)) \times 9.81 = 188 \text{ N}$

Mechanical advantage (MA) required = output force / input force = load / applied force

With a lever = $188 / 106 = 1.774$

Operating size of the scissor-type lift

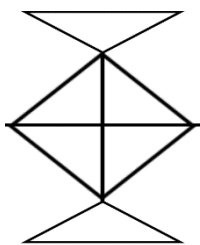

The scissor lift forms a diamond shape which can be considered as 4 triangles. If the angle at the base is 60 degrees when fully raised, then this gives an angle in each triangle of 30 degrees and an adjacent side of 333.3 mm (= $1000 / 3 \text{ mm}$).

Using trigonometry, the length of each arm of the scissor mechanism = $333.3 / \cos 30 = 385 \text{ mm}$.

This means when fully opened out the width of the device could potentially be 1540 mm. This is beyond the required height but sufficient for use.

Mass of the device

Lifting platform, base, and nylon sheet (from above) = $((2 \times 4.214) + 0.049) = 8.48 \text{ kg}$

Runner rails = $(\Omega r^2 \times 150 \times 2.7) \times 2 = 2531 \text{ kg}$

Fixings 4 × M5 × 30 bolts with nuts = 4×0.04 (from BS 3692) + 4×0.01 (estimate) = 0.1 kg

Total = $8.48 + 0.65 + 9.5 + 0.1 = 18.73 \text{ kg}$

Mechanical advantage of the scissor-type lift

If the screw lift has a pitch X_L of 3 mm, and a typical operating efficiency η of 0.3, then to raise a load of 188 N with a handle 200 mm long.

Work done on load = load × $X_L = 188 \times 3 = 564 \text{ N mm}$

Work done by effort = work done on load / $\eta = 564/0.3 = 1880 \text{ N mm}$

FE = work done by effort / X_E where $X_E = 2\pi \times 200 = 1257 \text{ mm}$

$$FE = 1880 / 1257 = 1.49 \text{ N}$$

$$\text{Mechanical advantage} = \text{load} / \text{applied force} = 188 / 105.9 = 1.77$$

Risk of failure

Tensile failure

$$\text{Cross sectional area of platform} = 0.51 \times 0.01 = 0.0051 \text{ m}^2$$

$$\text{Stress in lifting platform due to box} = 147 / 0.0051 = 56.3 \text{ kN} / \text{m}^2$$

Minimum yield stress of aluminium > 90 MPa, steel > 250 MPa dependent upon alloy, and minimum shear stress aluminium > 25 MPa, steel > 74 MPa

Assuming that the top is also made from 10 mm thick material, then its minimum width (assuming the weakest material, aluminium) would be where $90 \times 10^6 = 147 / (0.01 \times w)$; Rearranging $w = (147 / 90 \times 10^6) / 0.01 = 3.2 \times 10^{-4} \text{ m}$

and for the weakest material in shear strength (aluminium) would be $25 \times 10^6 = 147 / (0.01 \times w)$; Rearranging $w = (147 / 25 \times 10^6) / 0.01 = 5.9 \times 10^{-4} \text{ m}$

Risk of buckling - Maximum possible deflection of the lifting platform

$$I = bh^3 / 12 = 0.51 \times 0.01^3 / 12 = 4.25 \times 10^{-8} \text{ m}^4$$

Taking the lifting platform as a cantilever beam (ignoring any support from the runner rails), and assuming the maximum mass of box is loaded at 260 mm from the edge with the lift (representing the maximum possible offset of the box within the platform) and the base is made from the material with the lowest Young's modulus (aluminium), the maximum deflection at the end of the lifting platform furthest from the arm would be

$$\delta_B = (F a^3 / (3 E I)) (1 + 3 b / 2 a)$$

$$= 147 \times 0.26^3 / (3 \times 60 \times 10^9 \times 4.25 \times 10^{-8}) (1 + 3 \times 0.25 / 2 \times 0.26) = 1.6 \times 10^{-3} \text{ m}$$

I.e. the maximum possible worst case deflection of the lifting platform from this load is 1.6 mm – hence the risk of bending or buckling is in practice negligible. (If steel is used, the maximum deflection is 0.47 mm).

Commentary

The candidate has produced wide range of appropriate design calculations that aid with and are fully relevant to producing a design that meets the design criteria and specification. For example, calculations related to the mass of the lifting plate and mechanical device, the different required mechanical advantages and the scissor lift operating size, as well as demonstrating that the risk of tensile failure and buckling failure/bending are not a concern. This shows the ability to effectively apply a wide range of engineering mathematics concepts to the design context, including volume, density, forces, loads and trigonometric identities.

The candidate has demonstrated the ability to undertake all design calculations with accuracy, and with use of appropriate methodology, showing an informed level of understanding of the engineering principles that are reflected within the design. They have applied these accurately and in detail within the required context, linking directly back to the requirements of the design specification. Standards have been referenced where appropriate. For example, using BS 3692 when calculating the mass of mechanical fixings.

1f) Engineering drawings

Candidate evidence

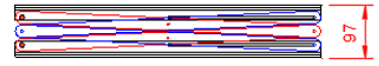
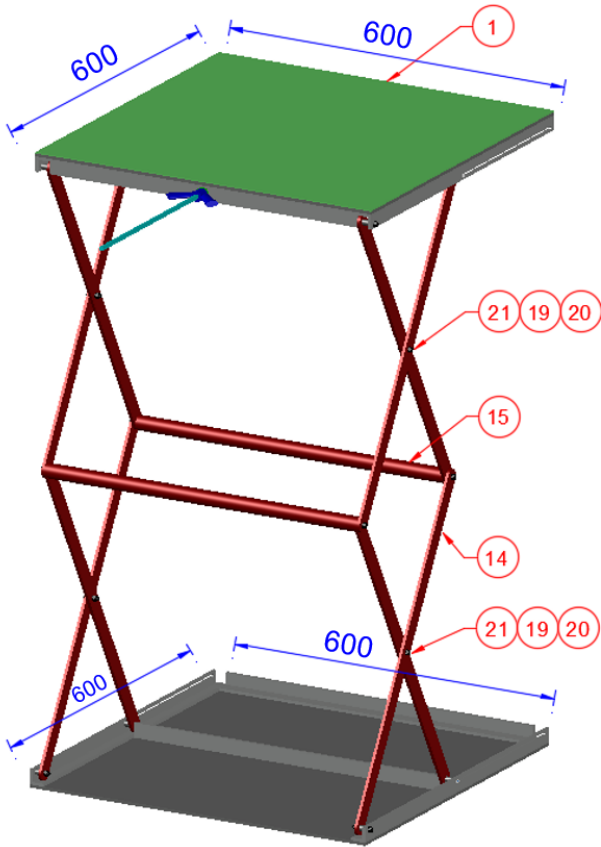

CLOSED POSITION
HEIGHT INCLUDES NYLON MAT

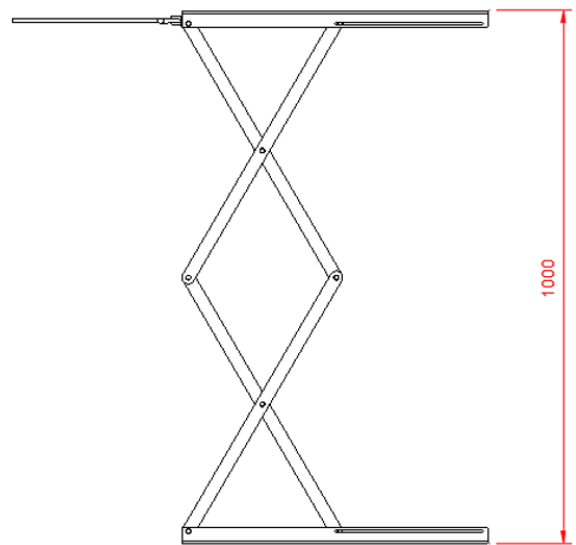

OPEN POSITION
HEIGHT INCLUDES NYLON MAT

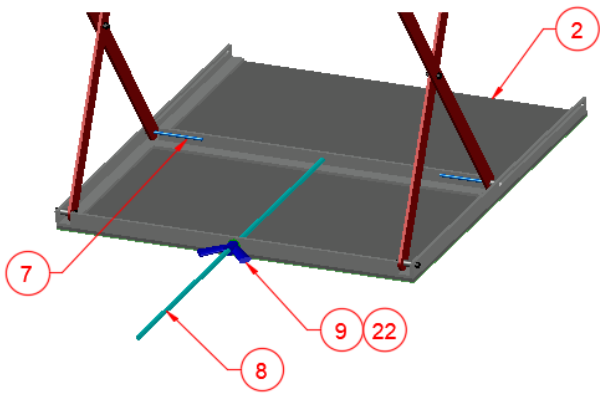

FRONT UNDERSIDE VIEW OF TOP PLATE

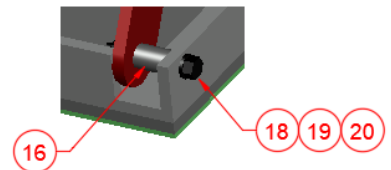

SCISSOR LEG / BRACKET CONNECTION DETAIL 1

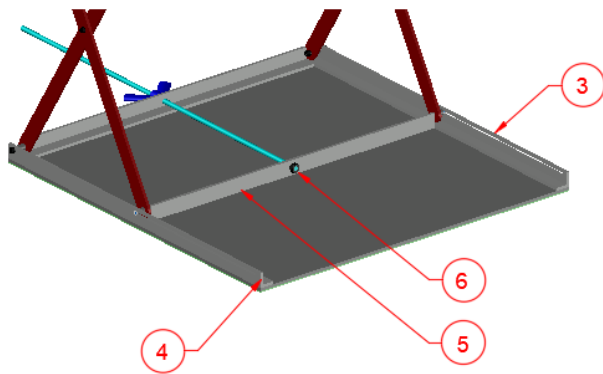

REAR UNDERSIDE VIEW OF TOP PLATE

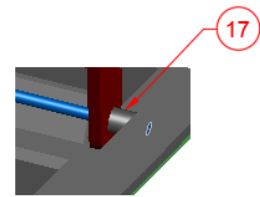

SCISSOR LEG / BRACKET CONNECTION DETAIL 2

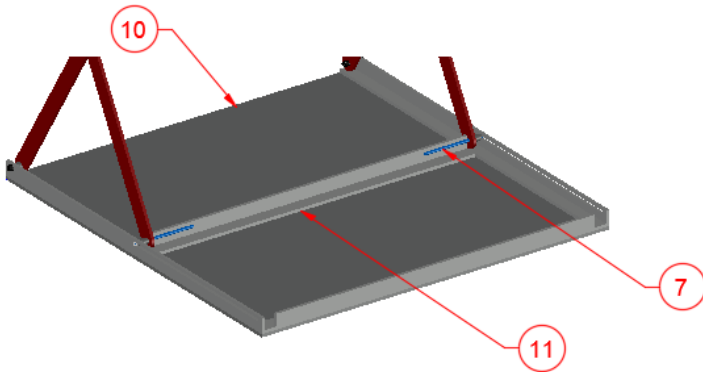

REAR UNDERSIDE VIEW OF BASE PLATE

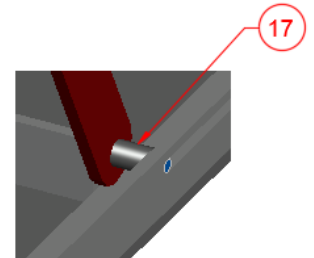

SCISSOR LEG / BRACKET CONNECTION DETAIL 1

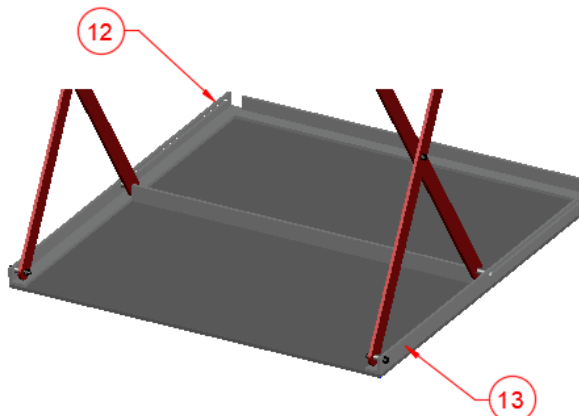

FRONT UNDERSIDE VIEW OF BASE PLATE

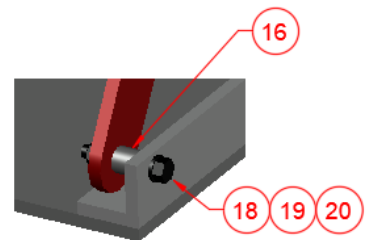

SCISSOR LEG / BRACKET CONNECTION DETAIL 2

PARTS LIST		
PART No.	DESCRIPTION	QUANTITY
1	NYLON MAT - 600 x 600 x 2 THICK	1
2	TOP PLATE 600 x 600 x 5 THICK	1
3	TOP PLATE - SIDE BRACKET - RH - 25 x 25 x 5 THICK	1
4	TOP PLATE - SIDE BRACKET - LH - 25 x 25 x 5 THICK	1
5	TOP PLATE - SLIDE BRACKET - 25 x 25 x 5 THICK	1
6	WELDED NUT - M8	1
7	RUNNER RAILS - M5 x 100 LONG	4
8	STUDDING - M8 x 650 LONG	1
9	HANDLE - M8	1
10	BASE PLATE 600 x 600 x 5 THICK	1
11	BASE PLATE - SLIDE BRACKET - 25 x 25 x 5 THICK	1
12	BASE PLATE - SIDE BRACKET - LH - 25 x 25 x 5 THICK	1
13	BASE PLATE - SIDE BRACKET - RH - 25 x 25 x 5 THICK	1
14	SCISSOR LEG - 600 x 25 x 5 THICK	8
15	SCISSOR LEG BRACE - Ø25 x 550 LONG	2
16	SPACER - FIXED - Ø10 x 15 LONG	4
17	SPACER - SLIDER - Ø10 x 10 LONG	4
18	BOLT - M5 x 35 LONG	4
19	WASHER - M5	16
20	NUT - M5	8
21	BOLT - M5 x 20 LONG	8
22	WASHER - M8	1

Commentary

The candidate has produced a set of engineering drawings for all the main components and a general assembly drawing showing the relative location of the parts in the product. These are clear and in accordance with the relevant conventions. The information that would be needed for a third party to manufacture the parts is included.

The drawings are clearly annotated with numbered balloons which correspond to a detailed parts list. The overall view shows the design clearly and contains size annotations for the top and base plates, as well as the height of the platform when open and closed. Multiple detailed close ups of the different components are also provided, all clearly annotated. The parts list is comprehensive and accurate.

1g) Outcomes of the virtual modelling of the proposed design

Candidate evidence

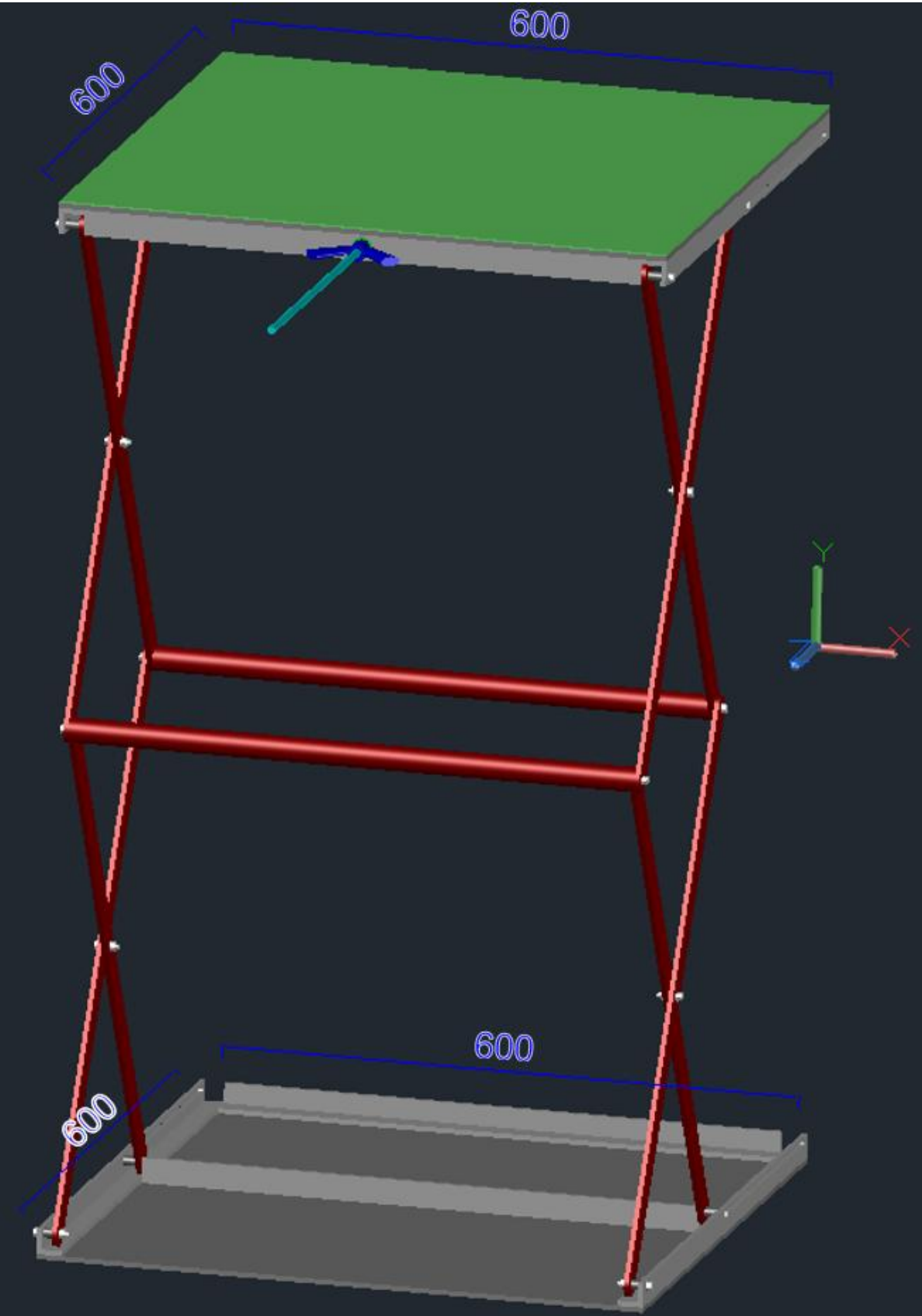

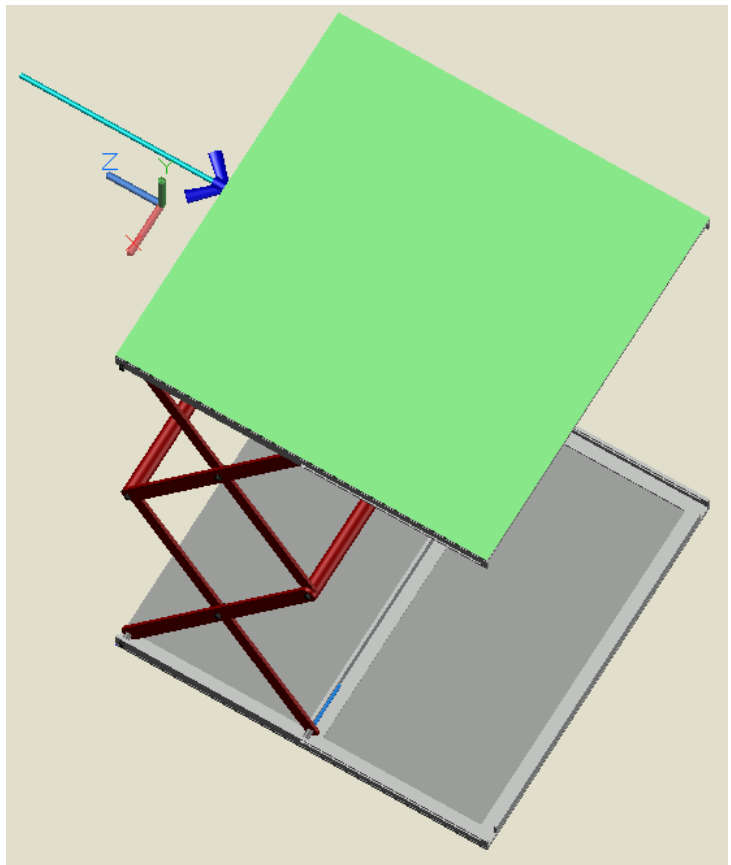
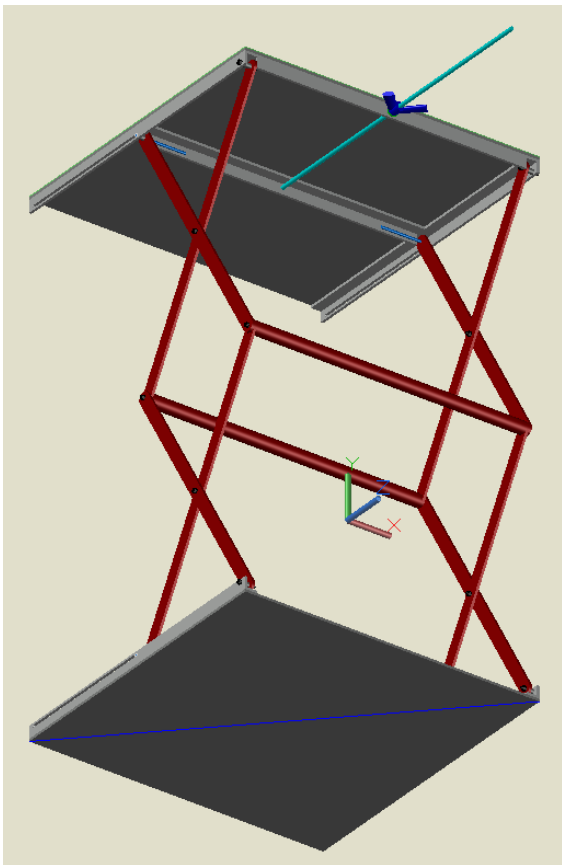
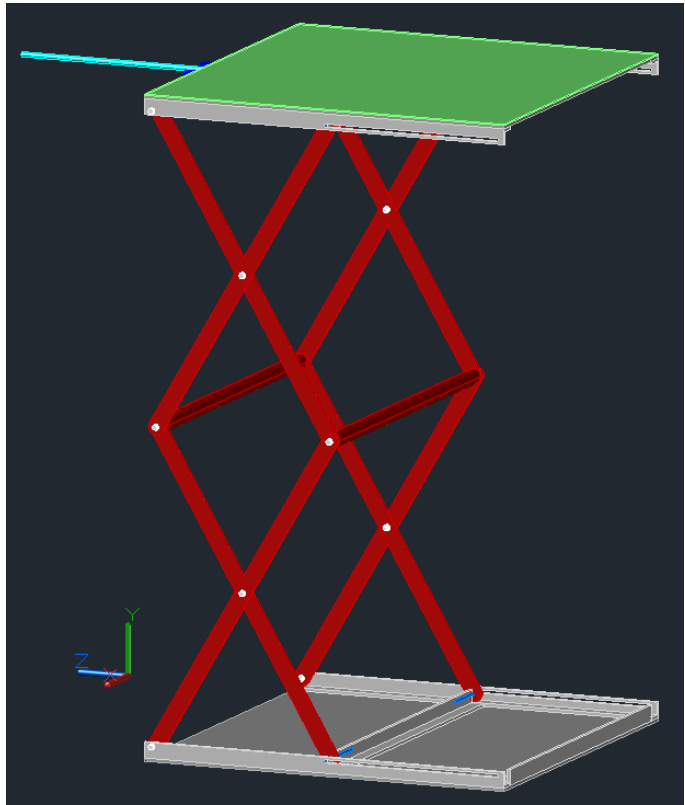
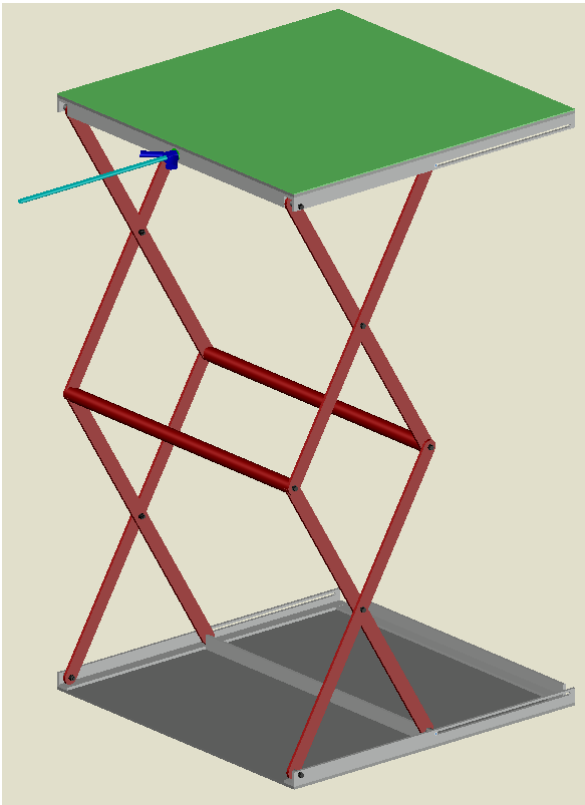

Commentary

The candidate has produced a good virtual model using 3D CAD software to show the appearance of the prototype and confirm the fit of the parts. The parts have been correctly aligned and positioned and the model is accurate, demonstrating comprehensive use of the modelling tools of the CAD software. The model fully aligns with the engineering drawings. It includes detailed views of the plates, the handle and the scissor lift. The multiple angles and multiple viewing modes shown also give a good overview of the relative placement of the parts.

The model contains the essential size annotations as well as the axes, without repeating all the remaining dimensions that were included in the engineering drawings in part 1f. The annotations show how it meets the relevant the requirements in the design specification.

1h) Bill of materials

Candidate evidence

I have compiled the following Bill of Materials. This outlines all of the materials and components that will be required to make the lift. The dimensions of each part are in the engineering drawings presented in part 1f.

Component	Material	Size	Quantity	Reason
Lifting platform and base	Aluminium sheet	4 mm thick, 600 × 600 mm	2	Lower density than steel so lighter weight (see design calculations for justification). Cut from sheet of standard thickness.
Runner rails	Aluminium rod	5 mm diameter × 1.5 m	2	Chosen as can be TIG welded to the aluminium base plate. 5 mm as a standard size.
Lifting arms	Steel plate	4 mm thick	8	Steel for high strength as must support the full load. Cut from sheet of standard thickness.
Handle	Steel rod	10 mm diameter × 200 mm long	1	Strong and rigid (high Young's modulus) so wont bend easily.
Mechanism	Stainless Steel threaded bar	1.5 mm pitch, 1 m maximum raise	1	Bought in item as easier and cheaper than making – supporting efficient development of the prototype.
Bolts	Steel	M3 × 30 mm	8	Bought in item as easier and cheaper than making – supporting efficient development of the prototype.
Nuts	Steel	M3	8	Bought in item as easier and cheaper than making – supporting efficient development of the prototype.
Knob for handle	Brass		1	Bought in item as easier and cheaper than making – supporting efficient development of the prototype.

Commentary

The candidate has produced a detailed bill of materials that contains all materials and quantities required to manufacture a prototype to meet the requirements of the design brief, criteria and specification. All specific quantities and sizes required are also included and fully appropriate to the design. The full dimensions of the components are shown in the engineering drawings.

Detailed reasoning has been provided for the choice the materials selected for each component, with reference to a number of key engineering principles evident. For example, showing the use of steel rod for the handle to support it to not bend, and identifying the properties of the material selected for the mechanical handle. Where bought-in or standard components are appropriate to use this has been identified and reasoning given, and appropriate part numbers identified, for example the use of M3 nuts.

Task 2 – Manufacture and test

(Assessment themes: Health and safety, Manufacturing, Reports)

For task 2, candidates need to produce the following pieces of evidence:

- a) risk assessment
- b) manufactured prototype
- c) test records for the operation of the prototype.

- Assessor observation of:
 - manufacturing
 - testing the prototype.

Photographic evidence which shows:

- the step-by-step construction of the lifting device (photographs 1-6)
- the fit and relative orientation of the mechanical parts (photographs 6-10)
- the final prototype (photographs 7-10)

The following supporting evidence has not been included for this version of the guide standard exemplification materials:

Video evidence which shows:

- functionality of the prototype.

2a) Risk assessment

Candidate evidence

The following risk assessments are based on the hazard and risk after the stated control measures have been applied. In the absence of the control measures, both hazards and risks would be much higher. The calculated risk rating is found by multiplying the likelihood and severity and is based on the listed control measures being in place. The risk likelihood is based on the scale shown in the table below. With the listed control measures in place, all of the risks are considered to be managed appropriately.

Hazard(s)	Risk(s)	Control measures	Risk	
			Likelihood	Severity
Working area when manufacturing and testing the prototype	Slips, trips, and falls	Ensure area is clean and tidy with no trip hazards and any spills (oil, water) mopped up. Wear safety shoes.	4	1
Pillar drill	Entanglement in the chuck	Use machine guards. Tie back hair and ties.	2	3
	Flying debris/ ejected wood chippings	Use machine guards. Wear safety glasses. Sweep debris between operations.	2	1
	Workpiece not held securely	Hold work piece in a machine vice or clamp to bed of drill with a G clamp.	2	2
Noise	Miss alarm sounds	Visual aid on the alarm, notify others that work will begin with excessive noise and to notify each other agreed safely.	3	2
	Hearing loss / impairment	Wear ear protection	3	3
Dust	Breathing impairment	Have appropriate ventilation/extraction when cutting and filling.	3	2
	Slips and falls	Ensure all dust/debris is swept away appropriately after tasks.	3	1
Fire	Burns / death	Ensure that all flammable waste is appropriately disposed of. Fire alarm. Fire procedure and fire stewards in area.	2	4
Electricity (Electric hand tools)	Burns, fire, electrocution	Regular PAT testing sticker on device. Visual inspection for exposed cords before use. Correct storage of portable electric devices.	2	4
Hand tools	Sharp edges on cut material	Wear gloves.	5	1

Likelihood		Severity	
1	Very unlikely to happen	1	Minor injury
2	Unlikely to happen	2	Major injury
3	Possible to happen	3	Loss of limb
4	Likely to happen	4	Death of an individual
5	Very likely to happen	5	Multiple deaths

Commentary

The risk assessment is detailed and identifies almost all of the associated hazards (exceptions being entanglement in the mechanical hacksaw and welding fume). The candidate has correctly recognised that multiple hazards may exist for different parts of the process. For example, the range of hazards that would be evident when using welding equipment.

The candidate has identified a range of appropriate control measures for all the potential risks and hazards. The candidate has recognised that in a number of cases, multiple control measures would be effective to support risk mitigation and in doing so, shows that a variety of scenarios and situations that could arise have been considered. Likelihood and severity have been considered separately for each hazard associated with a process.

2b) Manufacture of the prototype

Candidate evidence

I have decided to make the prototype out of wood as it has similar properties to aluminium (even though aluminium is stronger). Tensile strength = 27.6 - 34.5 MPa of plywood (base and top) Pine lift arms Tensile strength = 104 MPa

By building the prototype from wood, it means that if I notice something that I had not considered so far, I can make small modifications without cost expense.

To be timely, making the prototype **only** out of wood will be quicker and I will be able to meet my tight deadline. Welding will be substituted by using glue. Nuts and bolts will be used for the hinges and screws as fixings.

Wood is 100% recyclable as long as the metal has been removed, and the metal components can be reused by my college.

This is all built to a 1:2 ratio to give me a realistic perspective of the lift.



Photograph 1 shows the candidate's tool selection. These are all thoughtfully laid out, for example the nuts and bolts are kept in compartments and the wood parts are neatly collected in piles.



Photographs 2 and 3 show the sides for the runner rails marked up. The position of the holes for the runners is clearly marked and detailed annotations are included. The candidate has temporarily placed the mechanism sliders in situ for consideration.

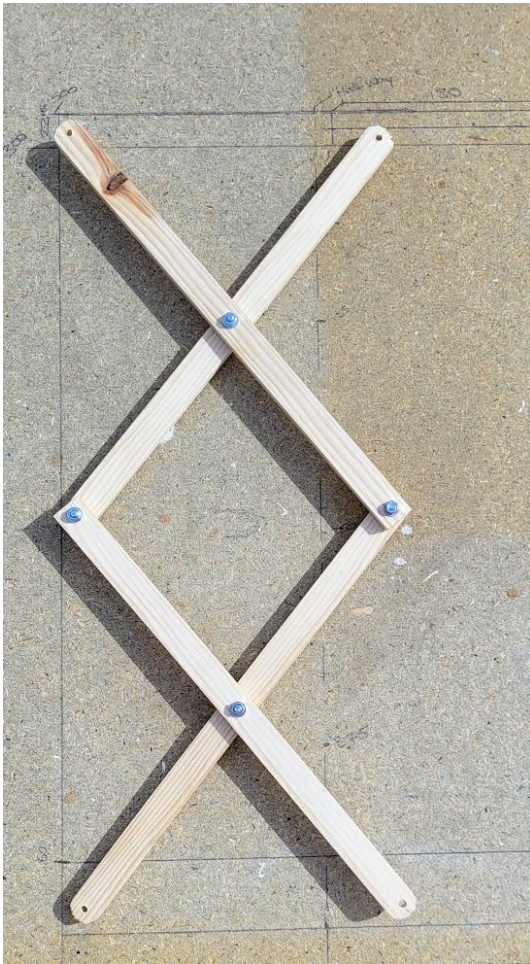

Photographs 4 and 5 show the markings and the assembly process of the prototype using a rod board for accuracy. The holes have now been cut out of the rails and they are neat and well aligned.



Photograph 6 shows accurate cutting length and measuring to 300 mm, with an extra 10 mm to allow for the prototype to have some fore and aft movement on the runner.

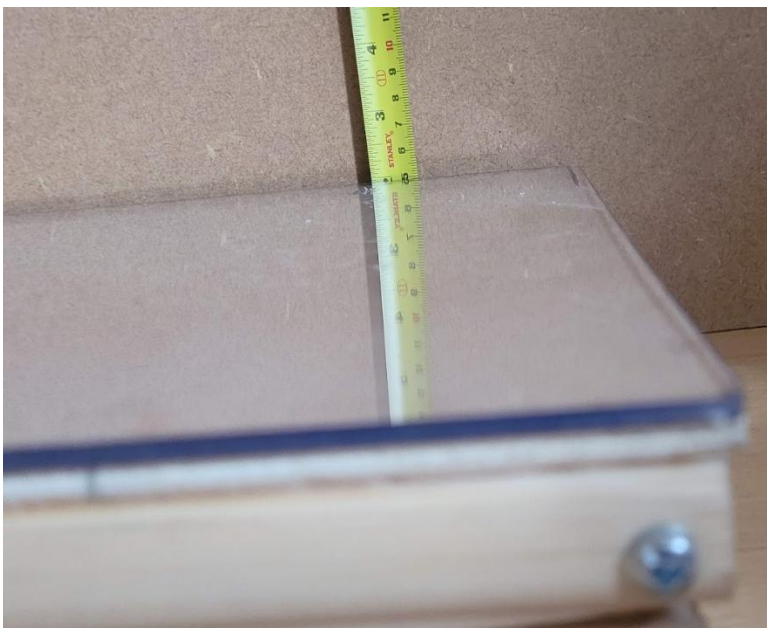

Photograph 7 shows the lifting platform at its lowest height of 50 mm, which meets the scaled dimensions required. The low-friction surface on the top plate is also visible.



Photographs 8 shows the platform lift at the halfway point. The lift is functional and can be raised and lowered smoothly as planned using the threaded bar mechanism.

The cut legs of the scissor lift are rounded off and are smoothed out to prevent injury.



Photographs 9 and 10 show the platform lift fully extended to the maximum height. In the photograph, the platform is raised to slightly above 500 mm, but it was then lowered to 500 mm, as per the height requirement, using the threaded bar mechanism. The runner rails are neatly cut and are fully functional.

Practical observation form

Assessment ID	Qualification number
8714-321	8714-31
Candidate name	Candidate number
Candidate A	CG12345
Centre name	Assessment theme
City & Guilds	Health and Safety Manufacturing

Complete the table below referring to the relevant marking grid, found in the assessment pack. **Do not** allocate marks at this stage.

Task	Notes – <i>detailed, accurate and differentiating notes which identify areas of strength and weakness are necessary to distinguish between different qualities of performance and to facilitate accurate allocation of marks once all evidence has been submitted.</i>
Manufacture and assembly of lifting mechanism	<p>The candidate correctly marked out the base and lifting platform using a scribe, pencil, engineer's square and steel rule. These were then accurately cut to dimension using a hacksaw and junior hacksaw, with all parts completed well within the specified tolerances in the design criteria and specification; whilst the parts were within tolerance, there was a very small variation in the linear dimensions due to operator misalignment. The edges were smoothed manually using files, producing a high level of surface finish. The runner rails and bar for the handle were cut on a hacksaw with excellent technique.</p> <p>The candidate then manually drilled holes in the correct locations using the pillar drill. They constructed with a simple positioning jig (also made by the candidate) to ensure the holes were produced within tolerance and repeatable. The runner rails were attached using glue, using a simple prefabricated jig. The bolts were fixed in place manually and correctly tightened. Care was taken not to overtighten.</p> <p>All work was completed safely and in line with their risk assessment and mitigating against all risks as they arose. The candidate implemented all the control measures in their risk assessment when using all of the manufacturing processes. They selected appropriate tools and ensured these were safe for use before beginning work.</p> <p>The prototype was fully functional when operated, with a smooth lifting and lowering motion, and meets all of the requirements of the design brief and criteria, and all but one of the requirements of the design specification.</p>

Assessor signature	Date
<i>Assessor 1</i>	03/04/2022

Commentary

The candidate completed the work safely throughout all the tasks. All hazards and risks that occurred were correctly mitigated against and their risk assessment was followed comprehensively throughout. Checks were performed on all tools and equipment to ensure they were safe before use.

The selection of tools, equipment and processes were fully appropriate to all of the tasks completed. The use of tools and equipment and the quality of most components and the assembly was excellent throughout, resulting in a prototype that meets all the design criteria. Whilst one requirement of the design specification was not met initially, this was immediately identified and appropriately rectified.

The candidate ensured a high quality of surface finish, for example, through filing edges using a file. They also took several steps to ensure accuracy, precision and repeatability, for example, using jigs to drill holes and assist with gluing. One of these jigs (to produce holes) was manufactured by the candidate themselves, demonstrating an extra layer of skill.

2c) Testing

Candidate evidence

Test records

All testing was completed on a wood substitute material with a ratio of 1:2. All records have been converted to demonstrate the ability to meet the requirements in full dimensions, as per the table below:

Component	Original size (mm)	Build size 1:2 (mm)
Top and base x2	600 × 600 × 5	300 × 300 × 2.5
Leg brace x2	600 × 2.5 diameter	300 × 1.25
Slider bracket x4	25 × 25 × 600	12.5 × 12.5 × 300
Legs x8	600x × 5 × 5	300 × 12.5 × 2.5
Slider support x2	600 × 25 × 25	300 × 12.5 × 12.5
Sliders x2	M5 × 1000	M2.5 × 500

	Design criteria	How this was tested	Test outcome
1.	The minimum size of the lifting platform must be at least 500 × 500 mm. Planned for 600 × 600	Measured with a meter rule.	600 × 600 mm pass
2.	The device must be capable of lifting 147 N (15 kg)	Functional test with 15 kg box.	Pass.
3.	The maximum effort required to raise the load should be 107 N	Applying a load of 10 kg (= 98 N) to the handle to see that this moved it.	Pass.
4.	The device should give a mechanical advantage of at least 2.2 to lift the maximum load	Design calculation.	MA > 100. Pass.
5.	The device must be capable of lifting the load from 100 mm above ground level to a height of 1 m to allow the boxes to be loaded/unloaded.	Functional test with 15 kg box.	Alignment +/- 1 mm. Pass.
6.	The device must be able to return to its start position	Functional test with 15 kg box.	Pass.
7.	The mechanism should be operated by a lever	Functional test.	Pass.
8.	The lever must be positioned at a height between 0.1 and 1.5 m	Measured with a meter rule.	Between 0.1 and 1.5 m depending upon platform height. Pass.

9.	The device must weigh less than 15 kg	Measured on stores scales.	14 kg. Pass.
10.	The lifting platform should be manufactured from aluminium (wood used as a substitute).	Checked materials certificate.	Pass.
11.	The lifting platform should have a surface with low friction	Checked materials certificate was nylon and functional test.	Box slid on without difficulty Pass.
12.	The platform must have no sharp edges	Silk test.	No snags. Pass.
13.	Any parts that move or rotate must be guarded or covered	Visual inspection during functional test.	Pass (when linen cover in place).
14.	At least 70% by weight of the materials used in the device should be recycled or recyclable	Based on measured weights of metal and nylon.	= $21.95/22 = 99.7\%$ Pass.
15.	The device should be made from standard-sized forms of material	Standard sizes used – checked design drawings.	Pass.

Practical observation form – Functional testing of the prototype

Assessment ID	Qualification number
8714-321	8714-31
Candidate name	Candidate number
Candidate A	CG12345
Centre name	Assessment theme
City & Guilds	Health and Safety Manufacturing

Complete the table below referring to the relevant marking grid, found in the assessment pack. **Do not** allocate marks at this stage.

Task	Notes – <i>detailed, accurate and differentiating notes which identify areas of strength and weakness are necessary to distinguish between different qualities of performance and to facilitate accurate allocation of marks once all evidence has been submitted.</i>
Testing of the prototype	<p>The candidate scaled down the lifting device to make testing feasible, and all records were converted to what would be real if this was made from metal as proposed.</p> <p>The candidate tested starting and finishing height by winding up and down the lifting mechanism on the table with an appropriately mounted measuring tape. The candidate was provided with a box of the maximum dimensions and weight and performed an appropriate functional test.</p> <p>The candidate set up the device adjacent to the pre-positioned shelves provided by the centre to check starting and finishing height, however these were scaled down to match the scaling of the prototype. This was in a different location to the height testing but due to being made of wood the effort to relocate was minimal.</p> <p>The lifting platform was in line with the entry shelf when positioned by the candidate. The candidate easily pushed the box into position. The candidate turned the handle to raise the box until it was aligned with the exit packing table, then pushed the box onto the table. Approximately 30 turns of the handle were required, which appeared to be relatively low effort. The accuracy of alignment was determined by the number of turns from the user and appeared to be relatively good. No modifications were required for the mechanism to achieve the functional requirements.</p> <p>The candidate worked independently to lift the device from the test area.</p>

Assessor signature	Date
<i>Assessor 1</i>	03/04/2022

Commentary

Testing was carried out against all of the design criteria. The testing was carried out on a scaled model and the candidate included a detailed table to explain how the scaling down of the calculations was done.

The candidate selected appropriate objective tests (the use of the meter rule for measurement and the silk test) to check that features met the design criteria. Functional testing was used appropriately to evaluate some of the main performance aspects in the design criteria.

The prototype was considered to have met the stated requirements. However, it was observed that the end of the handle (lever) could exceed the range specified in the specification – this is a minor inaccuracy in the reporting of the test outputs.

The candidate completed a test record of the findings clearly, in the form of a table comparing the results to the specification. Correct terminology was used throughout. The record lists the tests and outcomes, although some of the tests were missing very minor details - for example, where the dimensions were measured and how the 10 kg load was applied to the handle.

Task 3 – Peer review

(Assessment themes: Reports)

For task 3, candidates need to produce the following pieces of evidence:

- candidate notes on the candidate feedback record form

The candidate notes are not included in this document as the notes will vary from candidate to candidate and are not used to inform any other task.

- peer review feedback form.

This is supporting evidence for assessors to see what feedback the candidate received and how they used it in their review for task 4, and will not be marked.

Peer review feedback form

Candidate name	Candidate number
Candidate B	CG01234
Centre name	Centre number
City & Guilds	12345

Question	Feedback
How well does the design meet the requirements in the brief?	<i>I think the design is generally good. It meets the requirements of the brief well. It can raise the box at the required height and support the weight. The runner rails are a good idea, as these would stop the lifting platform moving out of horizontal alignment when placed in the appropriate corresponding location. It lines up well with the picking shelf at the ground and the packing table at the higher level. I thought the quality of finish was very good and the product looked aesthetically pleasing.</i>
How appropriate is the equipment proposed for the design?	<i>The equipment used seems to be generally appropriate. It is light enough for the user to move around and seems to be robust, so I think it wouldn't get damaged by minor knocks as things are moved around in the stores area. I don't like that the height of the handle moves up and down with the lift, as that means the user has to bend over to use it, especially when it is close to the floor. Older workers might get a bad back from bending over a lot. Also, a wheel might be easier for a worker to turn than a handle.</i>
What are the implications to the business of the proposed design?	<i>It should make lifting things in the stores a lot easier. It will take longer to lift using the device than just lifting by hand, but because it is easier, this probably means that workers can lift more over the course of a shift. There would also be less risk of getting a bad back due to manual lifting, so workers are less likely to need time off for injuries. It should also mean less effort is needed for manual lifting, which would make workers get less tired and stressed. <i>It takes a while to raise and lift each box, so it might mean that less work gets done in the stores and therefore affect the efficiency of the overall operation. If this could be improved in some way, then I think that would be a good thing.</i></i>
How can the design be optimised/ improved?	<i>I think you should include a larger threaded bar with a coarser thread leading to fewer turns of the handle. This would make it easier for the operator to use. I think that it could also be improved by adding a lip around three sides of the lifting platform so that when the user pushes the box on, it won't go too far.</i>

Task 4 – Evaluation and implementation

(Assessment themes: Health and safety, Design and planning, Reports)

For task 4, candidates need to produce the following pieces of evidence:

- a) outcomes of virtual modelling
- b) revision control document
- c) evaluation and implementation report.

4a) Outcomes of virtual modelling

Candidate evidence

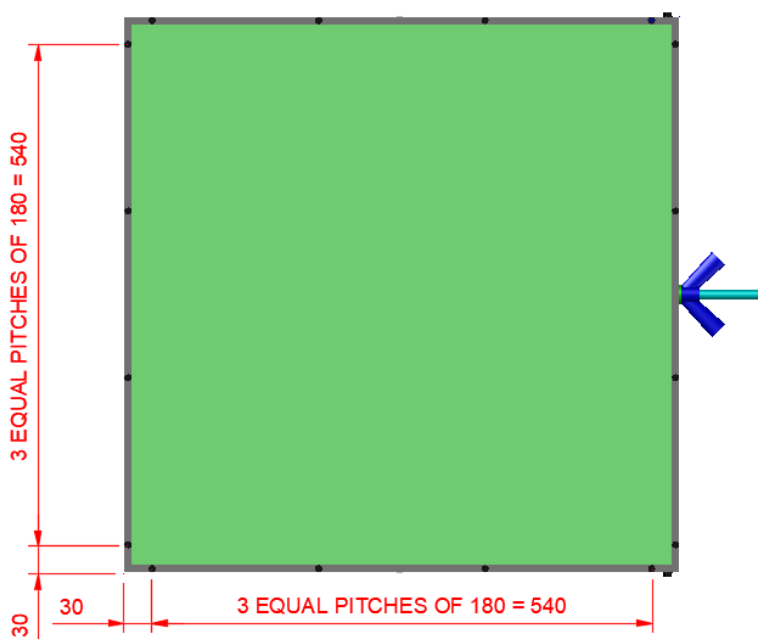
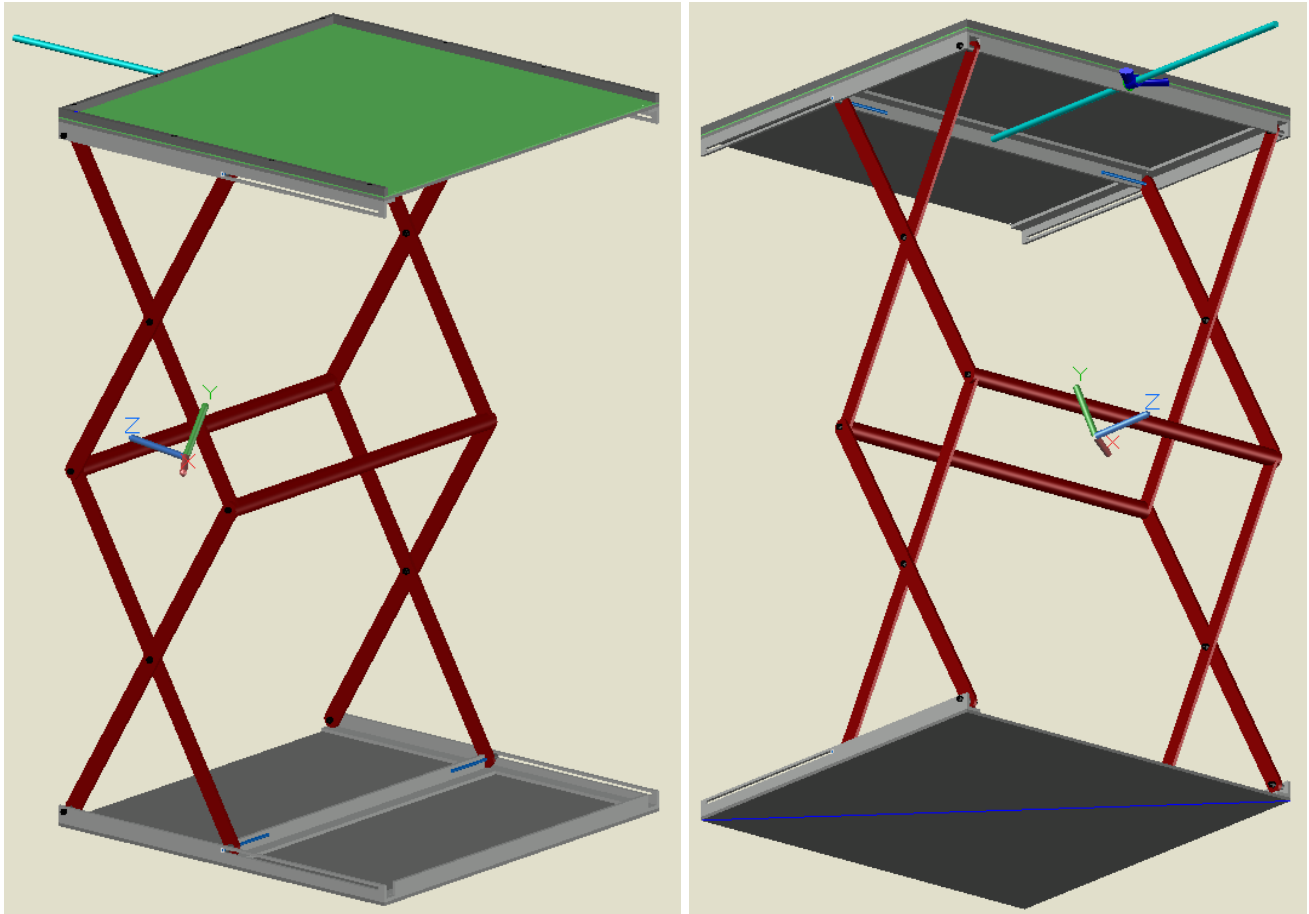

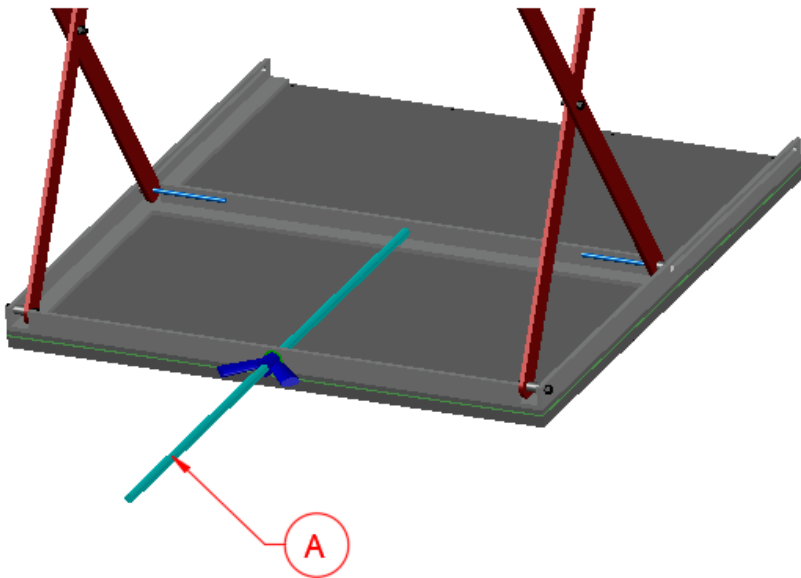

FRONT UNDERSIDE VIEW OF TOP PLATE

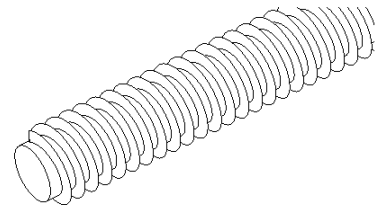

DETAIL A:
STUDED BAR DETAIL
M10 COARSE THREAD

Commentary

The candidate has produced a detailed virtual model incorporating the changes they decided on, namely a larger threaded bar with a coarser thread for the handle, and a lip on three of the edges of the lifting platform to stop the boxes from moving off the side or too far.

The screenshots of the overall model show the top and under side of the top plate, with the added lip visible clearly. The candidate has included a drawing of the top plate with marked up places for the tapped holes they would need to add to the nylon sheet, so that the lip can be attached. The drawing the top plate includes accurate dimensions.

A close up view of the underside of the top plate provides a clear view of where the coarser M10 studded bar would be placed, and a detailed view of it demonstrates the thread.

4b) Revision control document

System type	Manually powered mechanical lifting device
System TAG number	A1B2C3
Department responsible for equipment	Design and Development department
System designed by:	Candidate A

Design description:

This is a device to lift boxes from at a height of 100 mm to 1 m. Boxes are removed from a picking shelf, are manually pushed onto the lifting platform, raised by turning a lever, and then pushed onto a packing table in the opposite direction. The boxes are cuboid with a maximum side of 500 mm and a maximum weight of 15 kg. The device uses a scissor-type lift which is located to the sides so that it does not impede movement and connected to the base and a raising platform. Runner rails help to ensure that it remains in the correct alignment and provide a leverage point. The user raises and lowers the platform to the height and position needed. The mechanical advantage provided by the mechanism means much less effort is needed to lift the boxes compared to lifting by hand.

Changes to existing system:

Candidate B made a number of suggestions which I have considered. They suggested changing the lever to a wheel as they thought this would be easier to turn. I went back to check the ergonomics and anthropometric data tables that I used when completing the specification, and from this I saw that this would not actually result in an improved outcome, so this change was rejected.

Another suggestion was a larger threaded bar with a coarser thread (M10) leading to fewer turns of the handle. I agreed with this change as it has the advantages of reducing the number of turns, which means that it is more convenient and user friendly for the operator.

Finally, Candidate B suggested adding a lip around three of the sides of the platform. to ensure that the boxes could not be pushed too far. Again, I agree with this change as it would improve the functionality of my design and make it more commercially viable. This could be made from a thin strip of nylon or acrylic and attached with machine screws, countersunk to avoid the risk of snags against the operator's hands or clothing.

Changes to existing technical documentation:

An additional engineering drawing would be required for the lip so that it could be cut to the correct size.

The engineering drawings for the lifting platform and nylon sheet would need to be modified to include tapped holes so that the lip can be attached. Also, to accommodate a larger threaded bar the dimensions of the top mechanism housing will change to accommodate this. The handle will require adjustment due to a thicker bar being used.

The standard operating procedure (SOP) for making the lip would need to be created, and the SOPs for the production of the lifting platform and nylon sheet would need to be modified to include the tapped holes, to provide instructions for the safe manufacture of these parts.

The bill of materials needs to be amended to add the lip and four M4 × 8 machine screws to attach the lip.

The design criteria and specification and any technical manuals explaining the use of the system would still be valid without amendments.

Comments:

Overall, I am happy with the feedback received and have acted on the main points given by each candidate as they improve the design. I have suggested changes based on these that would help my design to meet the criteria more effectively.

Validation performed by:

Assessor 1

Prototype approved by:

Assessor 1

Date:

16/06/2022

Commentary

The candidate has read and taken into account the feedback from the peer reviewer. They have identified two changes to the design that are suitable and would enhance further their design solution. They have provided details about the changes, such as the method of attaching the lip to the lifting platform and given clear justification for how these changes support their design in terms of functionality.

Where changes have not been incorporated, the candidate has provided a clear rationale to confirm why they chose not to incorporate these suggestions. For example, the suggestion to change the lever to a wheel, and how this has not been accepted based on the original ergonomic tables used to develop the design.

The candidate has produced a revision control document that covers the main requirements and documentation that would need to be updated. They have correctly identified the drawings and documents that would need to be changed or produced and given detailed reasons as to why these changes are required.

4c) Evaluation and implementation report

Evaluation –

Before manufacturing the prototype, the mechanical advantage was calculated to ensure it met the specification requirements. Using relative data for a handle of 200 mm, the mechanical advantage was calculated to show the efficiency of the lifting activity:

$$\text{Mechanical advantage} = (\text{load} \times \text{pitch} / \text{typical efficiency}) / (2\pi \times \text{handle length}) / \text{applied force} = 441 / ((147 \times 1.5) / 1.16) / (2\pi \times 200) = 15.1$$

A virtual model was used to ensure that the parts fitted together correctly and to simulate the loading, to give confidence that the structure would be sufficient to resist the stresses caused by the maximum loading.

The evaluation of the physical prototype was carried out by comparison with the specification.

Functional testing was used to assess several criteria, as this gives the best indication of how well it will work when it is used in context. This involved setting up the lifting device in the scenario described in the brief, with a picking shelf and a packing table at the correct height and moving a box of the maximum possible size and weight. The lifting platform was manually aligned and moved from the picking shelf onto the platform and from the platform onto the packing table, achieving accurate alignment in both the pick-up and drop-off positions. This required minimal effort to raise and lower the platform (due to the mechanical advantage) and push the box on and off the surface (due to the lubricity of the nylon sheet).

The functional testing was supplemented by objective tests including:

- measuring the main dimensions of the platform with a meter rule to ensure it could accommodate the maximum stated dimensions
- checking the weight of the mechanism was under 15 kg using scales, so that it could be lifted by a worker acting alone
- carrying out a silk test to ensure that there were no sharp edges
- using the materials certificates to calculate the proportion of material that could be recycled.

Additionally, the drawings were inspected visually to verify that all the components would be manufactured from standard forms and sizes of material, to minimise costs.

Overall, the testing showed that all of the requirements of the design specification were achieved.

While the prototype worked well and met the requirements of the specification, it can be further improved to satisfy the brief even better:

- Include a heavy linen cover for the front of the scissor lift mechanism. This acts as a guard to stop other things getting caught when the lift is raised and lowered (which would otherwise be a risk during use).
- Put a nylon 'lip' around the edge of the lifting platform, so boxes cannot be accidentally pushed off the platform, reducing the risk of damaging the boxes or injuring workers.
- Add wheels to the base so that it is even easier for the user to move it.

Implementation –

For a third party to implement the prototype they will need the following information and documentation:

- The initial design criteria from the brief and final design specification from task 1.
- The bill of material from task 1, so suitable materials can be purchased.
- The engineering drawings for each of the individual components from task 1, to provide dimensional requirements for manufacturing activities.

- The general assembly drawing from task 1, to show the relative locations of the parts during assembly.
- The risk assessments from task 2 and standard operating procedures (SOPs) or a production plan for making and assembling the parts, to facilitate the safe and reproducible manufacture of the mechanism.

A copy of the virtual model may also assist so they can see what the assembled device looks like.

The main health and safety considerations for the manufacturing Include:

- all workers should be trained and competent using the machines
- machine guards should be used where applicable
- personal protective equipment (PPE) such as safety glasses and gloves (for handling the cut parts, except when using the lathe, where gloves would increase the risk of injury)
- overalls should be worn to protect clothing
- loose clothing and hair should be tied back
- the standard operating procedures (SOPs) should be followed during production activities
- all the machines should be well maintained.

Commentary

The candidate has produced a good evaluation and implementation report with some excellent features. They have explained the functional test methods used and provided a brief justification for its use. They have also listed some of the objective tests carried out and their purpose.

They have identified a comprehensive range of improvements each supported by a reason, although these justifications lack detail. These changes are suitable and would be beneficial to the design.

The candidate included a calculation of the mechanical advantage to illustrate the operating efficiency of the device, although this drew on some manufacturers data so may not be accurate for this mechanism. Health and safety considerations were covered for both the design and outlined for the manufacturing implementation.

The candidate has provided a list of documentation relevant to implementation, indicating that they have some knowledge of their relevance and how they would be used by a third party to implement the manufacture.

Copyright in this document belongs to, and is used under licence from the Department for Education, © 2023 - 2026.

'T-LEVELS' and 'T Level' are registered trade marks of the Department for Education.

© City & Guilds Limited is authorised by the Department for Education to develop and deliver this T Level Technical Qualification.

City & Guilds is a registered trade mark of © City & Guilds Limited.