

**T Level Technical Qualification in  
Engineering and Manufacturing –  
Design and Development**

**8714-323 Control and Instrumentation  
Occupational Specialism**

**Grade Standard Exemplification Material  
Pass - Summer 2025**

Version and date	Change detail	Section
v1.0 31 <sup>st</sup> October 2025	First published	N/A
V1.1 24 <sup>th</sup> November 2025	Amendments in relation to City & Guilds Limited	Back Cover

# Contents

**Introduction..... 3**

**Grade descriptors..... 5**

**Task 1 Design ..... 6**

**Task 2 Manufacture and test ..... 30**

**Task 3 Peer review ..... 41**

**Task 4 Evaluation and implementation..... 45**

**Principal Moderator Commentary ..... 53**

# Introduction

## Summer 2025 Results

This document is aimed at providers and learners to help understand the standard that was required in the summer 2025 assessment series to achieve a pass grade for the 8714-323 Control and Instrumentation Occupational Specialism (OS).

The Grade Standard Exemplification Material (Grade SEM) evidence provided for the pass grade displays the holistic standard required across the tasks to achieve the pass grade boundary in the summer 2025 series.

The aim of these materials is to provide examples of knowledge, skills and understanding that attested to **eight marks above** pass standard (threshold competence) in summer 2025. It is important to note that in live assessments, a candidate's performance is very likely to exhibit a spikey profile and standard of performance will vary across tasks.

The Occupational Specialism is graded Distinction, Merit, Pass or Unclassified.



The pass grade boundary is based on a synoptic mark across all tasks. The materials in this Grade SEM are separated into two sections as described below. Materials are presented against a number of tasks from the assignment.

## Task

This section details the tasks that the candidate has been asked to carry out. What needs to be submitted for marking and any additional evidence required including any photograph/video evidence. Candidate evidence that was or was not included in this Grade SEM has also been identified within this section.

In this Grade SEM there is candidate evidence from:

- Task 1 - Design
- Task 2 - Manufacture and test
- Task 3 - Peer review
- Task 4 - Evaluation and implementation

## **Candidate evidence**

This section includes exemplars of candidate work, photographs of the work in production (or completed) and practical observation records of the assessment completed by provider assessors. This was evidence that was captured as part of the assessment and then internally marked by the provider assessor.

The Occupational Specialism brief and tasks can be downloaded from [here](#).

## **Important things to note:**

- We discussed the approach to standard setting/maintaining with Ofqual and the other awarding organisations before awarding this year. We have agreed to take account of the newness of qualifications in how we award this year to recognise that students and teachers are less familiar with the assessments (<https://www.gov.uk/government/publications/ofqual-guide-for-schools-and-colleges-2025/ofqual-guide-for-schools-and-colleges-2025#grading>), whilst also recognising the standards required for these qualifications.
- The evidence presented, as a whole, achieved eight marks above the pass grade boundary. However, performance across the tasks may vary (i.e. some tasks completed to a higher/lower standard than pass grade).

## Grade descriptors

**To achieve a pass (threshold competence), a candidate will be able to:**

Demonstrate a basic use of software/technologies to model, evaluate and produce engineering diagrams and simulations that meets the requirements of the brief.

Demonstrate basic technical skills when developing models and prototypes, resulting in a prototype that may require some modifications.

Apply basic knowledge and understanding of testing processes, resulting in a prototype that has been tested against most of the design criteria.

Interpret information, plan, assess risk and follow safe working methods appropriately when applying practical skills to an acceptable standard in response to the requirements of the brief.

Apply basic knowledge and understanding of the design principles required for control and instrumentation resulting in proposals and solutions that meet the minimum requirements of the brief.

Work safely showing an understanding and suitable level of awareness in the preparation and application of processes, selection and use of tools and manufacturing materials and components, resulting in tasks that are carried out with some minor errors.

Use industry and technical terminology accurately most of the time in both written and verbal contexts.

# Task 1 Design

<b>Assessment number (eg 1234-033)</b>	8714-323
<b>Assessment title</b>	Control and Instrumentation Occupational Specialism

<b>Candidate name</b>	<first name> <surname>
<b>City &amp; Guilds candidate No.</b>	ABC1234

<b>Provider name</b>	<provider name>
<b>City &amp; Guilds provider No.</b>	999999a

<b>Task(s)</b>	1
<b>Evidence title / description</b>	<p>Design specification</p> <p>Annotated sketches, block and wiring diagrams</p> <p>Design options for the sensors and output devices, with justifications</p> <p>Selection of appropriate process control device, with justifications</p> <p>All design calculations, including all workings</p> <p>Outcomes of the virtual modelling of the proposed system design, either as screen captures or printouts</p> <p>Bill of materials, with justifications</p> <p>Any notes produced of research undertaken including citation of sources and internet search history.</p>
<b>Date submitted by candidate</b>	DD/MM/YY

# Task 1

## Assessment themes:

- Health and Safety
- Design and Planning

## You must:

- produce a detailed design specification that builds on the design criteria given in the assignment brief, including any references to research used. The specification should include:
  - a definition of the operating limits of the system
  - an analysis of how system stability will be achieved.
- generate a suitable design for the control system, including:
  - annotated sketches, block and wiring diagrams for the system that show how it will function
  - selection of appropriate sensors and output devices, with justifications and all relevant calculations
  - selection of appropriate process control device, with justifications and all relevant calculations.
- produce a virtual model of the proposed design using appropriate software
- create a bill of materials (BoM) listing all of the parts required in the final design proposal, with justifications.

## Additional evidence of your performance that must be captured for marking:

none

# Candidate evidence

## Task 1

The assignment brief given to me was that I must create a ground source heat pump for domestic houses to replace gas boilers to reduce carbon emissions to help battle climate change. To do this I have to create a closed loop circuit that will work with 2 break down points. These breakdown points being that there are only to temperature values the circuit can work in before the circuit will counter act it to maintain a regulated marginal temperature. The temperature brackets are 0 degrees Celsius to 20 degrees Celsius. To achieve this goal, I must use sensors to read the actual temperature of the water flowing within the ground source heat pumps closed loop system so I can use that data to regulate the temperature of the water. To cool the water down I simply send a signal to the motor pump to push water up to the house to radiate heat and cool the water down. Then, to warm the water up I simply keep that flow of water until it reaches underground then which it will heat up and go back through the radiators.

The brief also wants a visual display of these processes happening so that the user knows the heat pump is working. To achieve this, I am going to be using LEDs as a way of display positive or negative information to the user so that they can fix the heat pump before major damage occurs. There will be LEDs for the temperature and LEDs for the flow sensor. If a serious problem does occur an engineer can be called down to check the Arduino based code for its serial communication to see what the problem is. This is a much more flexible way of fault finding because it ensures the qualified engineer can fix it safely without the user putting themselves in harms way. It is also easy to read since it will give you values from the sensors.

### Environment

- Usual competitors use a material called polyethylene which is a plastic used in their borehole operations. These holes are used to occupy water underground for heating in an underground heat source pump. I have found a better alternative which is making waves within the pipe industry. HDPE (High density polyethylene), this version is much more sustainable because it is also a Thermoplastic. This term refers to its ability to melt at high temperatures and be re-moulded into a different shape without releasing harmful gases or breaking apart. This is advantageous compared to Polyethylene because it has less of an impact on its environment. Although LDPE (polyethylene) is a thermoplastic it doesn't have the roughness or the tensile strength as HDPE. This is also an advantage of using HDPE, not only is HDPE one of the most recycled materials In the world it is great for boreholes since its tough and can be moulded easily to place it into shape.

PVC pipes are not considered environmentally friendly because it takes chlorine and carbon with ethylene and these chemicals when degraded are released into habitats which can affect its chemical footprint and kill of its biodiversity. This is because chlorine is toxic to plants and when the PVC pipe starts to break down it can kill roots to plants and affect the nature around it, this is a disadvantage because it makes PVC not eco-friendly, Most PVC pipes end up in landfill because of its recyclability. Although PVC is a

thermoplastic when heated the chlorine in PVC will be released as Hydrogen chloride which is a toxic gas. This then makes PVC hard to re-heat and re-treat, so it ends up in landfill to reduce risk and increase safety. A better alternative to PVC is PEX, PEX pipes are a very good material choice for this project because they are freeze resistant and cost much less than PVC. Although you can Recycle PEX because it is a Thermoset it has a very long-life cycle, so the cost benefit makes it an obvious choice.

### **Sustainability justification**

- To ensure that my boiler is sustainable I have used eco-friendly materials such as HDPE which can be recycled and re-used. This decreases the total carbon footprint of my project because the bore hole pipes can be recycled. This is an advantage for my project since the boilers sustainability will increase, and this can potentially increase the marketability of the boiler. One disadvantage of one of my material options is PEX since it is not recyclable. This is a disadvantage because if one of the Floor heating PEX pipes were to break it would then be sent to landfill. Although this is a disadvantage it is a justifiable material option since it has much more benefits compared to PVC tubing, and this is why I concluded in choosing PEX tubes. The choice of PEX tubing affects the sustainability of my project negatively since it is not recyclable however it has been justified. Another advantage of my project is the choice of using a vertical radiator approach since this approach has a holistic approach in terms of supply of hot water all throughout the year without the aided Assistance of a gas boiler to heat the water up when there is a colder season. This is because the vertical radiator approach uses the trapped heat from underground and the heat from in the crust of the earth isn't going anywhere anytime soon. And the vertical radiator approach capitalizes on this hence why it doesn't need a gas boiler to help rise the temperature in colder seasons. This affects the sustainability of my project positively; this is because without the use of a gas boiler the carbon emissions is dramatically decreased and the for the carbon footprint of my project plumets as a cause and affect of the gas boiler. This is an advantage because it helps the marketing of the boiler since it is more environmentally friendly and in the modern age environmentally friendly products in engineering are highly desired. This means that you can make the boiler cost more since it is in high demand there for driving more profit out of your customers.

# Task 1 - Resources

## PVC vs PEX

- One advantage of using PEX is that it is flexible and easy to manipulate which is where PVC fails. PEX can be bended and folded while maintaining a closed loop system which is why it is perfect for the underground heat exchange for the domesticated housing floor. However, PEX is not as rough as PVC since PVC has more toughness than PEX this is a disadvantage of PEX because it won't be able to take as much wear as PVC. However, one advantage of PEX is that it is freeze resistant which is good for this project because if the water in the pipes freeze and expand the pipe until it breaks PVC won't be a suitable choice for my project. This is because PVC doesn't have a lot of elasticity and will break under compressive loads. However, Because of PEX's high elasticity it can block pathways by folding or constricting flow of water by being push by an external object outside the closed loop. In conclusion I think PVC has its positives but for the Floor heat exchange I need a flexible material with high elasticity, so I have to chose PEX. Even though it is weaker than PVC it can be protected by floorboards and hidden away while providing heat.

## HDPE vs LDPE

- One advantage of using HDPE is that is a thermoset, this term refers to its ability to be heated and re-moulded into any shape you want. This is an advantage because it can be re-heated and recycled if somehow the pip was damaged while being in a borehole. This version of polyethylene takes a more holistic approach in terms of materials choice because LDPE doesn't have high density and there for cannot withstand as much damage as HDPE which is an advantage of HDPE. This relates to my project because I can use HDPE for the bore holes to reduce cost in maintenance due to its toughness and have a low carbon footprint since the HDPE is 100% recyclable. One disadvantage of using HDPE is that it can be harder to work with due to its increased density compared to LDPE, but this can be avoided by using heat to mould the pipe into the angle you want it to go. One advantage of LDPE is that it is easier to work with since it doesn't have the density that HDPE has this makes it easier to bend and manipulate for manufacturing and implementation. However, one disadvantage of LDPE is that is not very eco-friendly since it can be degraded over time due to its density and release microplastics into its surroundings. This is a disadvantage because those microplastic will affect the biodiversity of the soil around it and affect the organisms near it. This relates to my project because if I used LDPE pipes for the bore holes then microplastics would have been released into the soil over time and affect the micro-organisms and the biodiversity of that land. In conclusion I think the right choice for my bore hole pipe material is HDPE because of its clear advantages over LDPE and cost benefits also low maintenance.

# Task 1 - Annotated sketch justification

## Vertical radiator approach

- For my first draft I chose the Vertical radiator approach where bore holes will dig deep into the ground in search for heat which you can use to radiate heat into Bore hole pipes that are connected to a closed loop underground heat source pump heating system for domestic house use you can see this on the annotated sketch, I produced on page 2. One advantage of this approach is that the water will heat up fast in the underground heat since the heat has no where else to go other than the cold water. This is a beneficial key factor because the water will there for be ready to deploy into the home heating system much faster. Also, in colder seasons the user will have a higher demand for hot water compared to hotter seasons since the house will cool down much faster. This design approach can supply the high hot water demand in these seasons since the heat is trapped underground it won't be absorbed by the cold surface. This there for makes this design more holistic since it can provide a steady on demand heat in all seasons there for taking all factors into consideration in terms of hot water supply and demand in varying seasons. However, one disadvantage of the vertical radiator approach is that the bore holes can be expensive to construct because you must do a ground analysis to make sure you're not hitting any infrastructure like pipes or wires that could potentially stop supplying a network of grids. Although this is a disadvantage it is worth the extra expense since the supply of hot water is high and ready on demand.

## Horizontal radiator approach

- Another approach I tried instead of the vertical radiator is the horizontal radiator approach. This approach capitalizes on the excess thermal energy that the sun produces normally. You can see the annotated sketch I have produced on page three; the bore holes will be drilled horizontally so that the bore hole pipes can run along just underneath the surface. The reason the bore hole pipes are placed in a horizontal configuration is so that the surface area of the pipes is maximised. This is so the pipes can absorb as much thermal energy from the sun as they can since the increased surface area allows the sun to hit the pipes more compared to the vertical approach where the surface area is smaller. One advantage of using the horizontal approach is that during hotter seasons the supply of hot water on demand is increased dramatically since the suns thermal energy output has increased there for the rate of thermal energy absorption through the pipes has increased in turn. One disadvantage of the horizontal radiator approach is that during colder seasons the suns thermal energy will be absorbed by the cold surface and the waters rate of heat absorption would be decreased dramatically. This is a disadvantage because the user won't be able to have on demand hot water ready to heat up the house. This means that the user will have to use gas boilers until the thermal output from the sun is suitable enough so that the horizontal approach can be used. This makes the Horizontal approach reductionistic because it doesn't consider that the sun can't always output a continuous stream of thermal energy. There are cloudy days and foggy days where the suns pathway to the bore hole pipes will be reduced there for making the supply of hot water reduced in turn.

## Horizontal vs Vertical

- One disadvantage of using the vertical radiator approach is that the bore holes are harder to achieve compared to the bore holes on the horizontal approach. This is an advantage for the horizontal approach because the vertical approach's bore holes need to be deeper underground than the horizontal ones. The reason this is a disadvantage is because the surface will need to be analysed for infrastructure and hard materials such as rocks. Whereas the horizontal approach digs much lower compared to the vertical approach. Although this is an advantage for the vertical approach the horizontal approach does have many disadvantages. One disadvantage of the horizontal approach is that it capitalizes on the sun's thermal energy and the sun can't be hot all the time. This is a problem for the horizontal approach because once the sun isn't out the bore hole pipes can't absorb a lot of thermal energy there for making the water colder. And the only way to heat it up would be using a gas boiler which is what our employer is trying not to use so the design is flawed. Also, if we must rely on gas boilers to heat up the water during times with no sun in the UK, we'd be relying on the boiler to heat up the water a lot. This is also a disadvantage because the carbon emissions will increase because of the gas boiler, and that is what we are trying to reduce. This is why the horizontal approach is more reductionistic compared to the vertical approach since it can only work at its fullest during sunny seasons. However, the vertical approach is more holistic compared to the horizontal approach because it can work in all seasons because it relies on the heat underground. And the heat underground isn't going anywhere so it's a constant reliable source of heat throughout the year. This is an advantage for the vertical approach since the heat source is reliable and constant throughout the year. This relates to my project because I need a reliable source of heat ready on demand so the user can avoid using a gas boiler to heat up the water, so carbon emissions are reduced as much as possible. So, in conclusion I think the Vertical approach is the design I'm going to be using in my project because it has a reliable source of heat ready on demand for all seasons hot or cold. Which is positive for the user and my company because it avoids the need for a gas boiler.

## Task 1 - Virtual model justification

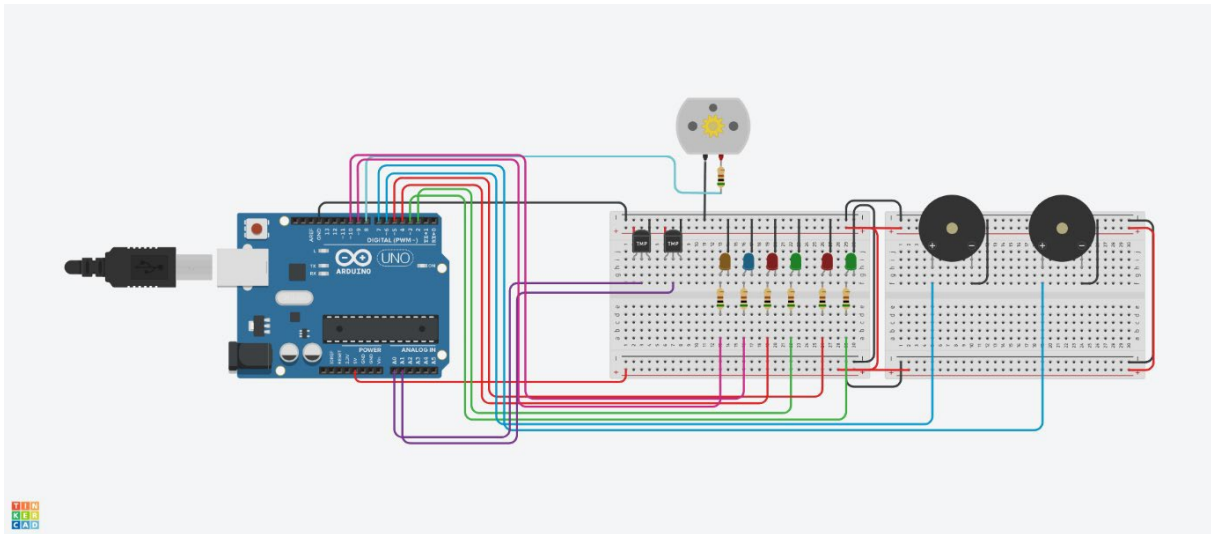

My tinker cad model design for my project is as shown, I have used various components I have listed on the BOM sheet. This model is for the electrical housing unit in the Vertical radiator underground heat source pump system. It will be housed within the EHU protected from the water and insulated. One disadvantage of my design is that it doesn't have a flow rate sensor. This is because tinker cad software does not have the flow rate sensor available. So, I used a TMP to simulate an analogue signal going into the Arduino to regulate the motor to spin when flow is low. The various coloured LEDs are used to represent different purposes. One section of the LED's is used for good/bad temperature readings, they are the red and green LEDs on the left. The red and green LEDs on the right are used to express good/bad flow rate. These are the visual representations in real time the company wants so it fits within the project brief. This is an advantage because it shows my design approach is valid and that I am working within the project parameters. The orange LED is to let the user know that the boiler is cooling down. Whereas the blue LED is to let the user know that the boiler is defrosting and heating up. The speaker on the left is used to let the user know from a distance that the boiler is not working within its temperature parameters and is either cooling down or heating up. This is why the colour coded LED's there to let the user know. The speaker on the right is used for letting the user know that there is not enough or no flow within the pump, so the system is going to start pumping water.

One advantage of using the colour coded LEDs to let the user know that the boiler is heating up or cooling down is that it is much easier to fix than an LCD display and easier to code in if the Arduino is broken. Another advantage of using colour coded LEDs is that it is much simpler to interpret compared to an LCD screen that will have loads of data that the user will need to break down to understand what the boiler is trying to tell the user. However, one disadvantage of my design model is that the use of a LCD display would give a more modern look to the boiler and be more aesthetic, most boilers in the modern world have displays to relay information to the user about the boiler. My design does not have this feature since it is a lot simpler compared to modern displays. Another disadvantage of my virtual design is that it does not have a flow rate sensor, this is a disadvantage because the use of an actual flow rate sensor can 100% prove that my

design works. The use of a substitute analogue input could potentially change the way the design works because flow rate and temperature devices work in different principles. However, this can be resulted by the fact that tinker cad did not have a flow rate sensor that I could use since tinker cad do not have the software for a flow rate sensor. Although it is a disadvantage the use of a substitute still shows that my virtual model still works, and my design is valid. This relates to my project because my project brief requires a working virtual model of the product which is what my virtual model has achieved. This there for makes my virtual model validated and also my justification relevant.

**Tinker cad wiring diagram**

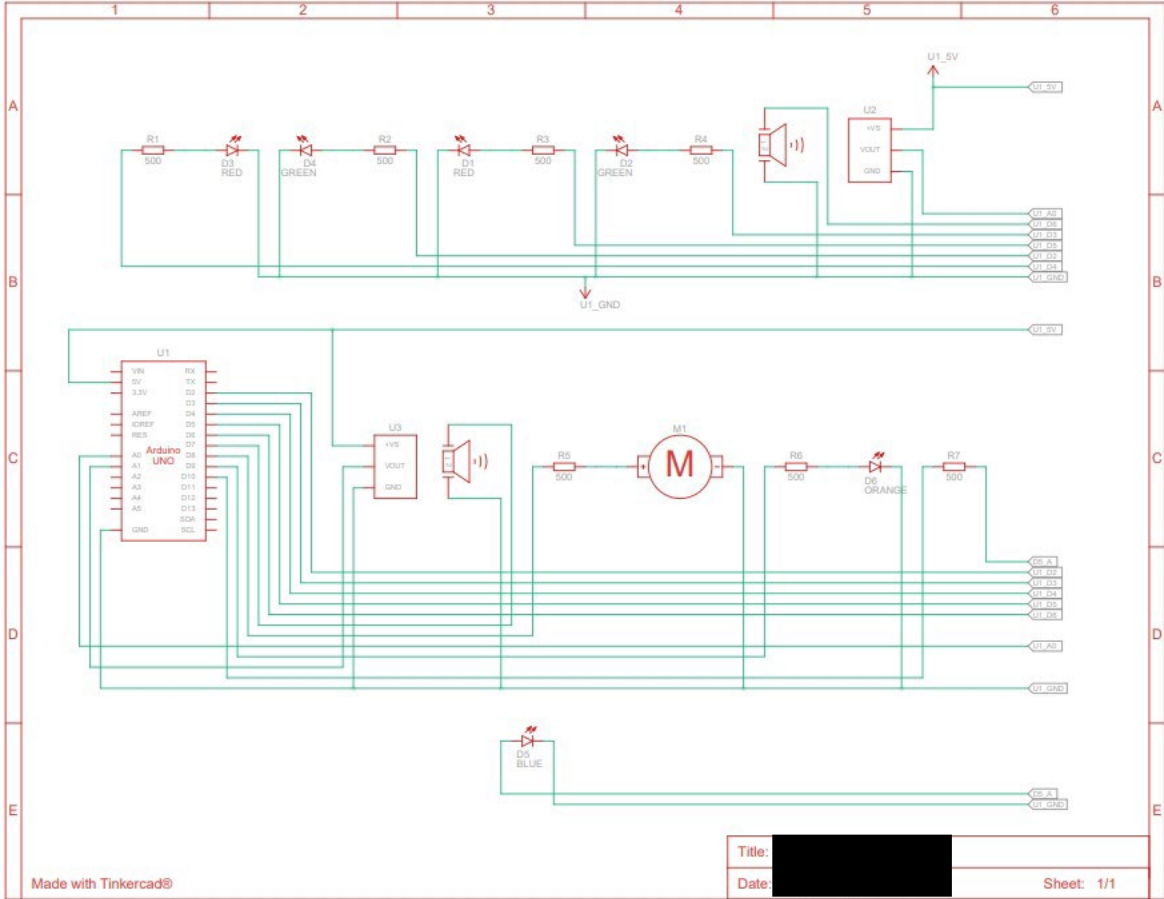

# Task 1 - Control system Justification

## Arduino UNO

- The control system I am going to be using for this project is an Arduino UNO, this device is a programmable logic computer that can be connected to inputs and outputs. Unlike a PLC an Arduino has an open-source code based library through a website called tinkercad. This is an advantage of using an Arduino because if you have a very simple project you want to complete the chances of the code being uploaded onto the Open-source IDE is very high. Arduinos are also very easy to use and are readily available they are cheap and easy to get your hands onto. One other advantage of using Arduino's is that they are easy to operate maintenance on since they just use wires connect to the output or input devices and all the engineers must do is disconnect the wire and replace the device or reconnect the wire. However, one disadvantage of Arduinos is that they cannot output a high voltage like PLC's can, Arduinos can only output a digital 5V from each pin and the Arduino can't handle outputting high currents over a long time since it will burn the Arduinos internals from overheating. Although this is a disadvantage of Arduinos, it can be easily counter acted using external PSU's and what I mean by that is batteries and transistors to amplify the current or voltage. This is great for our purpose because we can use an Arduino which is easy you use and operate on while being able to have a high voltage and current output to operate bigger outputs while keeping the Arduino protected. One other advantage of Arduinos is that they are perfect for prototyping a design since they can connect to breadboards and moved around easily and be stored in small boxes. This is why I am using an Arduino in my project because they can fit in small boxes such as the Electrical housing unit where the Motor pump will be stored.

## PLC

- PLC's stand for programmable logic computers, they are like Arduinos but use a completely different coding system which is not open source. Although, they work on the same theory of inputs and outputs. PLCs are mainly used in industrial operations, but they can be used in boilers since most motors work of 24V DC. One advantage of using PLC's is that they can output a higher voltage and current than Arduino's without the need for a transistor and an external PSU to amplify the voltage. This is an advantage for PLC's because it reduces the cost of having to buy transistors and batteries to help facilitate the voltage required to turn on the outputs. Although, one disadvantage of using PLC's is that they are expensive and bulky, PLCs aren't good for prototyping since they are used for finalised products in industrial buildings. This is because PLCs are bulky and durable while also easy to code since they use ladder logic diagrams (LLD). Another disadvantage of using PLC's is that maintaining a PLC can be troublesome since the components are bulky and much bigger than Arduinos which will take more time. More time means more downtime for the product which doesn't support TIMWOOD's waist reduction acronym because waist is being produced by not having the product working. To reduce time on maintaining the boilers operating system in the case of a fault occurrence use an Arduino.

## PLC vs Arduino

- One advantage of using PLC's is that they are robust and strong while being easy to code. This is an advantage because if you were trying to implement a new piece of hardware onto the boiler system the software wouldn't take too long to implement since the PLC uses Ladder logic diagram (LLD). However, one disadvantage of using PLCs is that they are big and bulky, and this would compromise the shape of the electrical housing unit because the PLC's size is much bigger in comparison to the Arduino. This is a disadvantage of PLCs because it means the EHU will need to be re-designed since we originally wanted to use an Arduino. One advantage of using an Arduino however is that it is small and compact, and its code is open source and easy to operate. This is an advantage because if you're trying to implement a new part of hardware into the boilers system you can find the code available online. This saves the operator time, and this supports the TIMWOOD model since the amount of time wasted creating your own software for the hardware is reduce by simply finding it online there for reducing time wasted. However, one disadvantage of using Arduinos is that they cannot supply a high voltage like PLCs can since they have a small PSU. This is a disadvantage for Arduinos since the output devices I am using for this project requires higher voltage than the Arduino can supply. To counter act this, I am going to being externa PSU's and transistors to amplify the voltage, although this will cost extra to buy, I think it is worth it because. Another advantage of using Arduinos is that they are good for prototyping products since they are light and easy to carry and can be stored easily. The Arduino can be connected to breadboards for prototyping new products such as mine. In conclusion I think I am going to be using the Arduino UNO for my control system and operating system for my projects prototyping since it is lightweight and can be stored easily. The Arduino UNO's code is also easy to create making the software development phase faster, this is a positive because the product can be designed faster and there for sold faster. Although the Arduino UNO cannot supply a high voltage, we can bypass this by using external PSUs and transistors so that the Arduino still has full control over the whole circuit.

## Task 1 – Calculations

-The Arduino will be outputting a steady 10 milli amps, this is a safe amount of current for the Arduino to output since Arduino themselves recommend about 20 milli amps.

- The drop voltages for my LED's

- RED = 1.8V

- Green = 3.5V

- Yellow = 2.3V

- Blue = 3.6V

TMP parameters:

Attribute	Value
Sensor Function	Temperature
Output Type	Voltage
Interface Type	Analogue
Accuracy	±0.2°C
Mounting Type	Through Hole
Pin Count	3
Minimum Operating Temperature	-40 °C
Operating Temperature Range	-40 to +110 °C
Maximum Operating Temperature	+110 °C
Minimum Operating Supply Voltage	4 V
Maximum Operating Supply Voltage	30 V
Package Type	TO-92
Length	5.2mm
Height	5.2mm
Width	4.19mm
Dimensions	5.2 x 4.19 x 5.2mm
Sensor Gain	10mV/°C

### Motor pump calculations:

Attribute	Value
Maximum Flow Rate	500 → 1000ml
Supply Voltage	6 → 12V
Input Connection	5.5mm Hose Barb
Maximum Head	3.5m
Maximum Working Pressure	340mbar
Body Material	Aluminium
Coupling Type	Direct
Input Power	1.5/6.7W @ 6/12V
Maximum Fluid Temperature	60°C
Input Connection Size	3.2mm
Output Connection Size	3.2mm
Wetted Materials	Anodised 6000 series aluminium, 316 Stainless steel, FKM, Polyacetal,  Materials typical to a brushless motor
Pump Type	Centrifugal
IP Rating	IP45

---

### Speaker calculations:

Attribute	Value
Coil Resistance	8Ω
Sound Level	104dB
Tone Type	Sine Wave
Rated Power	1W
Dimensions	36 (Dia.) x 4.8mm
Diameter	36mm
Height	4.8mm

## Flow rate sensor calculations:

Attribute	Value
Media Monitored	Liquid
Device Type	Turbine
Minimum Flow Rate	1 L/min
Maximum Flow Rate	25 L/min
Supply Voltage	5 → 24 V dc
Pipe Diameter Range	3/8 in
Connection Type	3/8 BSP
Maximum Pressure	200psi
Material	Nylon 12
Minimum Operating Temperature	-20°C
Maximum Operating Temperature	+100°C
Series	FT-110

## Task 1 – BOM list

- 1 TMP (LM35CAZ/NOPB | Texas Instruments Temperature Sensor, Voltage Output, Through Hole Mount, Analogue,  $\pm 0.2^{\circ}\text{C}$ , 3 Pins | RS)
- Water motor pump (RS PRO 6 → 12V 340mbar Direct Coupling Centrifugal Water Pump, 500 → 1000ml | RS)
- Arduino UNO (A000066 | Arduino Uno Rev 3 | RS)
- 9V Battery for Arduino (RS PRO Alkaline 9V Batteries PP3 | RS)
- Mixed LED's (AUKENIEN 500pcs 5MM LED Diodes Light Emitting Diode Assortment Kit 5 Colors Red Blue Yellow Green White Round LED Lighting Bulb Lamp Components for Electronics : Amazon.co.uk: Business, Industry & Science)
- Speaker 2X (RS PRO 8Ω 1W Miniature Speaker 36mm Dia. , 150mm Lead Length, 36 (Dia.) x 4.6mm | RS)
- Flow rate sensor (173940-C | Gems Sensors FT-110SeriesTurbineFlowSensor for Liquid, 1 L/min Min,25 L/min Max | RS)
- Wires(MIKROE-512, 150mm Insulated Breadboard Jumper Wire in Black, Blue,Brown, Green, Grey, Orange, Purple, Red, White, | RS)
- Bread boards 2x (SKU00089 | Monk MakesBreadboard forPico | RS)
- 500 ohm resistors (TE Connectivity 500Ω MetalFilmResistor 0.5W±0.1%UPF50B500RV|RS)

## Task 1 - References

I will be using Havard referencing in my Ref page:

- LDPE ([Is Polyethylene ecofriendly - Search](#), 27<sup>th</sup> March 2025)
- HDPE ([is HDPE eco-friendly - Search](#), 27<sup>th</sup> March 2025)
- Is HDPE a thermoplastic? ([Is HDPE is thermoplastic - Search](#), 27<sup>th</sup> March 2025)
- Is LDPE a thermoplastic? ([Is LDPE is thermoplastic - Search](#), 27<sup>th</sup> March 2025)
- Is HDPE a popular choice for recycling? ([Is HDPE a popular choice for recycling - Search](#), 27<sup>th</sup> March 2025)
- Underground heat exchanger ([Ground Source Heat Pumps in the UK: A Complete Guide \(2025\)](#), 27<sup>th</sup> March 2025)
- Are PVC pipes eco-friendly ([Are PVC eco-friendly - Search](#), 27<sup>th</sup> March 2025)
- Is chlorine toxic to plants? ([is Chloring toxic to plants - Search](#), 27<sup>th</sup> March 2025)
- Is PVC a thermoplastic? ([Is PVC a thermoplastic - Search](#), 27<sup>th</sup> March 2025)
- Does PVC release harmful gas when heated? ([Does PVC release harmful gases when heated - Search](#), 27<sup>th</sup> March 2025)
- Are PEX pipes eco-friendly ([Are PEX pipes eco-friendly - Search](#), 27<sup>th</sup> March 2025)
- Sun heated ground source heat pump ([sun heated ground source heat pump - Search](#), 28<sup>th</sup> March 2025)
- Drop voltages for coloured LEDs ([the drop voltage for coloured LEDs - Search Images](#), 31<sup>st</sup> March 2025)

## Task 1 – Code

```
void setup() //Setting up the pins and integers
{
  Serial.begin(9600); //Starting the serial communication language

  pinMode(2, OUTPUT); //Setting up which wires are connected to which pins
  pinMode(3, OUTPUT);

  pinMode(4, OUTPUT);

  pinMode(5, OUTPUT);

  pinMode(6, OUTPUT);

  pinMode(7, OUTPUT);

  pinMode(8, OUTPUT);

  pinMode(A0, INPUT);

  pinMode(9, OUTPUT);

  pinMode(10,
  OUTPUT);

  int sensor_value = analogRead(A0) ; //Storing analog data into this int
}
void loop() //Anything in this loop will repeated infintely
{
  int sensor_value = analogRead(A0);
  Serial.print("Sensor value =");
  Serial.print(" ");
  Serial.println(sensor_value);

  int Flow_value = analogRead(A1);
  Serial.print("Flow value ="); //Showing which value is which to make interpretation
  easier
  Serial.print(" "); //Creating space between the serial messages

  Serial.println(Flow_value); //Printing the analog data int

  {
  if (sensor_value > 102) //Decision making if statements to set up margins
```

```

    digitalWrite(2, HIGH);
else if (sensor_value < 142)
digitalWrite(2, HIGH);
}
{
if (sensor_value <
    102) digitalWrite(2,
    LOW);
else if (sensor_value > 142)
    digitalWrite(2, LOW);
}
{
if (sensor_value <
    102) digitalWrite(4,
    HIGH);
else if (sensor_value > 142)
    digitalWrite(4, HIGH);
}
{
if (sensor_value <
    102) digitalWrite(4,
    LOW);
else if (sensor_value > 142)
    digitalWrite(4, LOW);
}

```

```
}  
  
{  
if (sensor_value <  
    102) digitalWrite(6,  
    HIGH);  
else if (sensor_value > 142)  
    digitalWrite(6, HIGH);  
}  
  
{  
if (sensor_value <  
    102) digitalWrite(6,  
    LOW);  
else if (sensor_value > 142)  
    digitalWrite(6, LOW);  
}  
  
{  
if (Flow_value > 102)  
    digitalWrite(3, HIGH);  
}  
  
{  
if (Flow_value < 102)
```

```
digitalWrite(3, LOW);
}

{
if (Flow_value < 102)
    digitalWrite(5, HIGH);
}

{
if (Flow_value > 102)
    digitalWrite(5, LOW);
}

{
if (Flow_value < 102)
    digitalWrite(7, HIGH);
}

{
if (Flow_value > 102)
    digitalWrite(7, LOW);
}

{
if (sensor_value > 102)
    digitalWrite(8, LOW);
else if (sensor_value < 142)
    digitalWrite(8, LOW);
}

{
if (sensor_value < 102)
    digitalWrite(8, HIGH);
else if (sensor_value > 142)
    digitalWrite(8, HIGH);
}

{
```

```
if (Flow_value < 102)
digitalWrite(8, HIGH);
else if (Flow_value >
102) digitalWrite(8,
LOW);
}
{
if (sensor_value < 102)
digitalWrite(10, HIGH); else if
(sensor_value > 102)
digitalWrite(10, LOW);
}
{
if (sensor_value > 142)
digitalWrite(9, HIGH);
else if (sensor_value < 142)
digitalWrite(9, LOW);
}
}
```

# Task 1 – Diagrams and notes

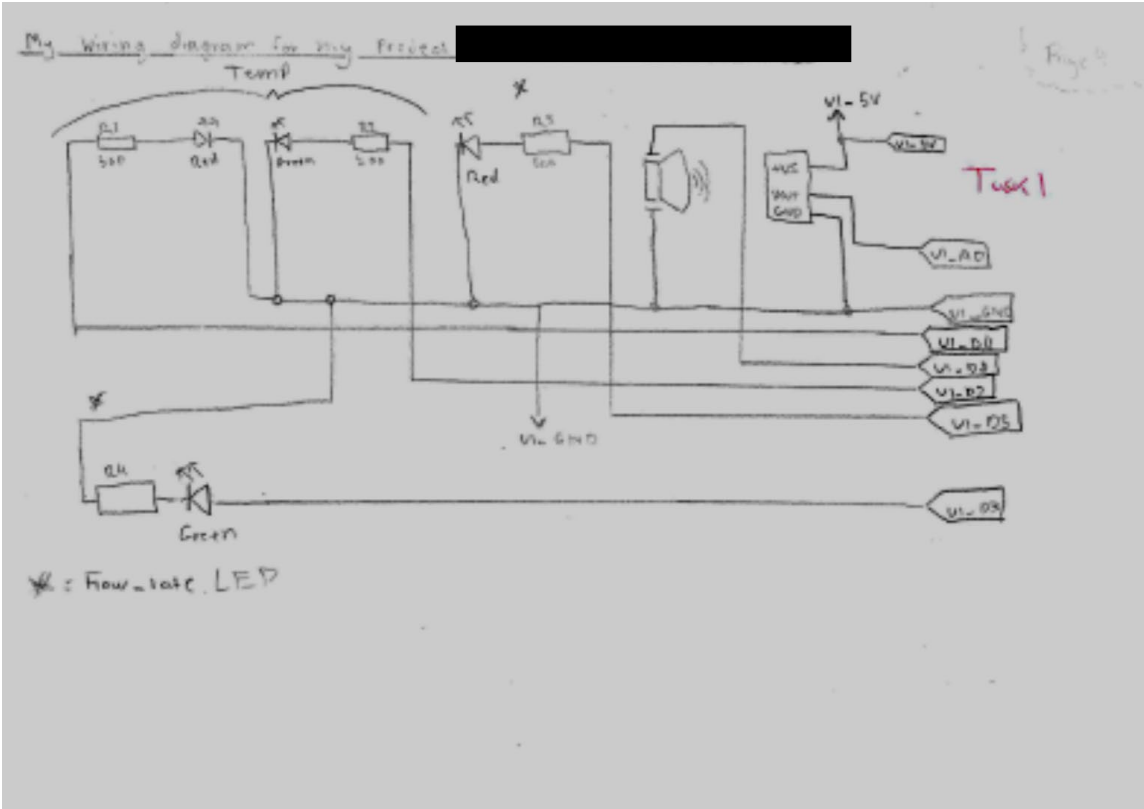
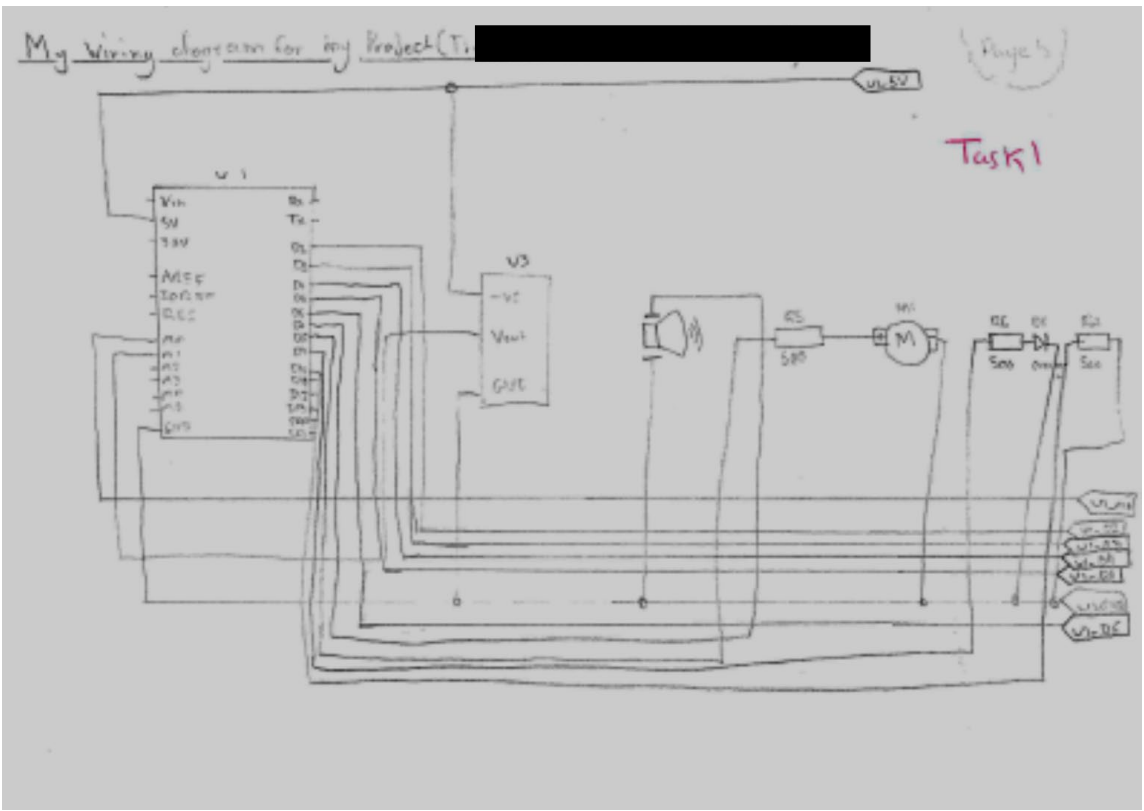

# Annotated sketch of my design Draft 2

Page base

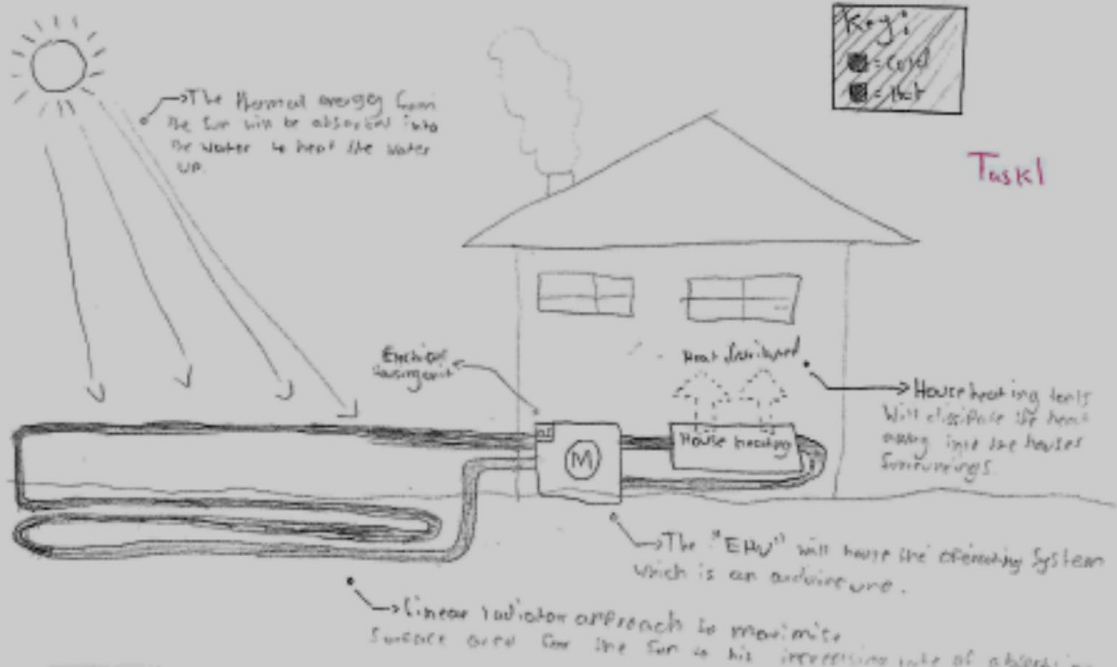

# Annotated sketch of my design Draft 1

Task1

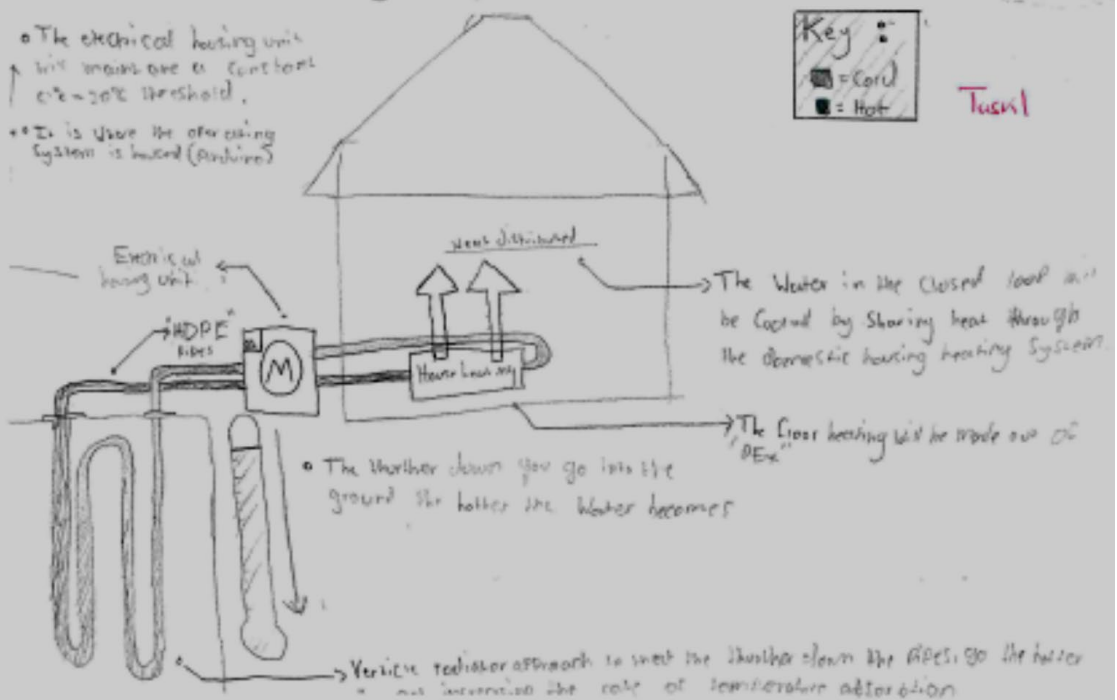

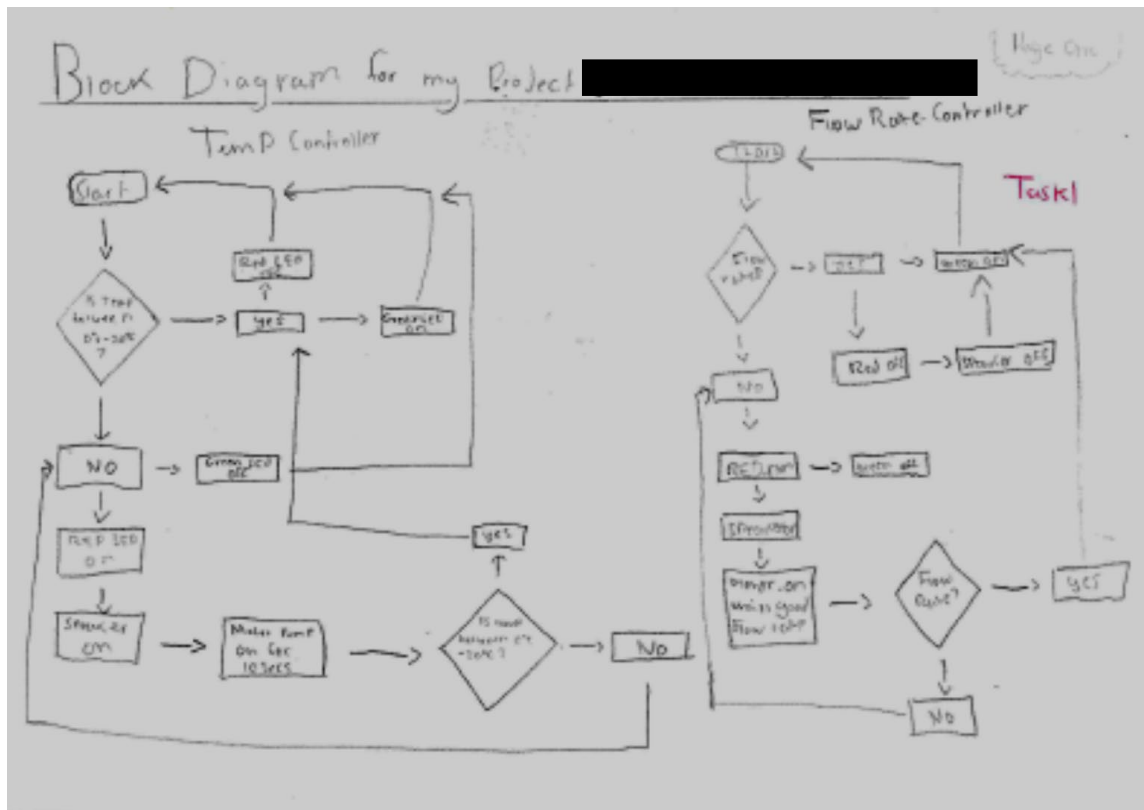

Phase one: [REDACTED]

Phase two: Page one, Task 2

- Drop voltage resistor calculations on 5mA

Red:

$$\frac{5 - 1.8}{5 \times 10^{-3}} = 640 \Omega (PF = 680 \Omega)$$

Green:

$$\frac{5 - 3.5}{5 \times 10^{-3}} = 300 \Omega (PF = 330 \Omega)$$

Yellow:

$$\frac{5 - 2.3}{5 \times 10^{-3}} = 540 \Omega (PF = 560 \Omega)$$

Blue:

$$\frac{5 - 3.6}{5 \times 10^{-3}} = 240 \Omega (PF = 270 \Omega)$$

Risk assessment:

- Prototype does work and is operating according to the design brief

## Task 2 Manufacture and test

<b>Assessment number (eg 1234-033)</b>	8714-323
<b>Assessment title</b>	Control and Instrumentation Occupational Specialism

<b>Candidate name</b>	<first name> <surname>
<b>City &amp; Guilds candidate No.</b>	ABC1234

<b>Provider name</b>	<provider name>
<b>City &amp; Guilds provider No.</b>	999999a

<b>Task(s)</b>	2
<b>Evidence title / description</b>	Completed risk assessment Photographic evidence Practical observation form
<b>Date submitted by candidate</b>	DD/MM/YY

## Task 2

### Assessment themes:

- Health and Safety
- Manufacturing
- Reports

You must:

- produce and complete a risk assessment for the manufacture of the prototype
- use a permanent manufacturing method to produce the prototype
- test and verify the operation of the completed prototype, recording your findings.

### Additional evidence of your performance that must be captured for marking:

- assessor observations:
  - manufacturing of the prototype
  - testing and verification.
- photographic evidence which shows:
  - sequence of photos during the manufacturing of the prototype to include:
  - result of tool selection and usage
  - wiring – dressing of cables and cable connections
  - control hardware
  - interfaces
  - sub-assemblies
  - final prototype.

# Candidate evidence

## Task 2 – Completed risk assessment

### Safety

- To ensure safety and abide the rules and regulations set out by the HSE organisation I am going to be using PPE in my manufacturing phase. This supports the health and safety at work etc act 1974, Me using PPE decreases the chance of a severe injury occurring. The PPE I am going to be using will be goggles and insulated tools to prevent electrical shock. All wires will be heat shrink and insulated to prevent any conductive material from being exposed. This is so there is no chance of electrical harm by accident. Risk assessments will be done to ensure the implementation process has little risk as much as possible to reduce potential harm during the manufacturing phase. Visual management tools such as warning signs and hazard stickers will be used to ensure the user doesn't harm themselves when maintaining their boiler. This helps reduce the risk of potential harm and serious injuries. This can also increase the lifespan of the boiler since the user won't be messing around with the equipment. To ensure the user doesn't maintenance our product without a professional we will form of non-value-added warranty and state within the contract if the user performs maintenance without calling us this will breach the warranty contract making it Null. This action will encourage the user to call the manufacturer before performing un-professional maintenance on the boiler

Risk	Likelihood	Severity	Protection	prevention
Electrical harm	Low	Low	Insulated tools	Test for voltage before you touch.
Stabs and jabs	Medium	High	gloves	Don't rush the manufacturing and wear gloves at all times
Slips and falls	Low	High	Anti-slip boots	Wear the PPE to reduce this risk and if the floor is wet grab a tissue paper and dry it off to reduce chances of slipping
Cuts and bleed	Low	High	Plasters and gloves	Make sure you know where the first aid kit is at all times and wear gloves to prevent cuts and wear plasters on open wounds to reduce chance of infection and bleeds

### Risk assessment for my manufacturing process of my prototype

Hazard	severity	likelihood	total	prevention	Aid
Cuts and jabs	2	1	2	gloves	Bandages and plasters
Electrical harm	3	2	6	Insulated tools and gloves	First aid equipment
Burns and scolds	4	1	4	Fire extinguisher and wet cloths	First aid and hospital facility
Slips and falls	3	2	6	Anti-slip boots and mats	Medical care and medical check ups
Injection injury	5	1	5	Tightened hose pipes with tape and zip ties	Medical facility and first aid equipment

## **Task 2 - Permanent manufacturing method for my Prototype**

- The prototype will be manufactured in a factory using pick and place robots or humans to pick and place the components using a construction sheet given by the company. The factory won't be owned it will be rented to do our work for us since building a factory just for one product one be a economically viable option. The product will then be tested using the ISO 9001 certification process to make sure our product has good quality. To make sure our product is up to date the product will also have to be test using the BSI quality standards as well. This is an advantage for my products profitability since the factory will be rented and not bought. This will save the company money and time in building a factory, The product will be more profitable because the cost is smaller in comparison to buying the factory out right.

## Task 2 – Photographic evidence

### Tool selection and usage



### Wiring – dressing of cables

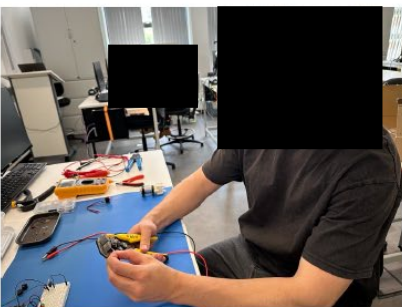
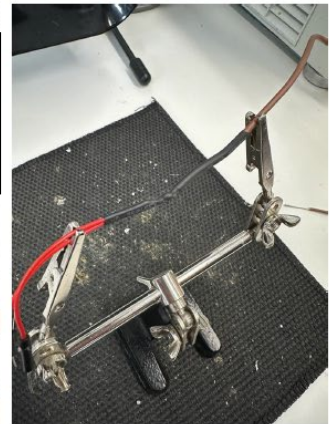
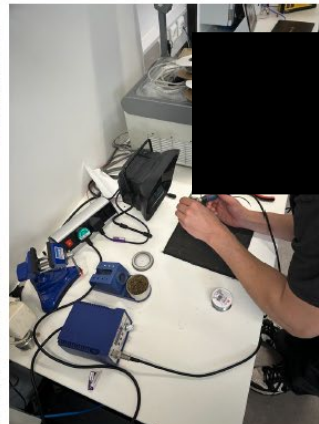

**Control hardware**

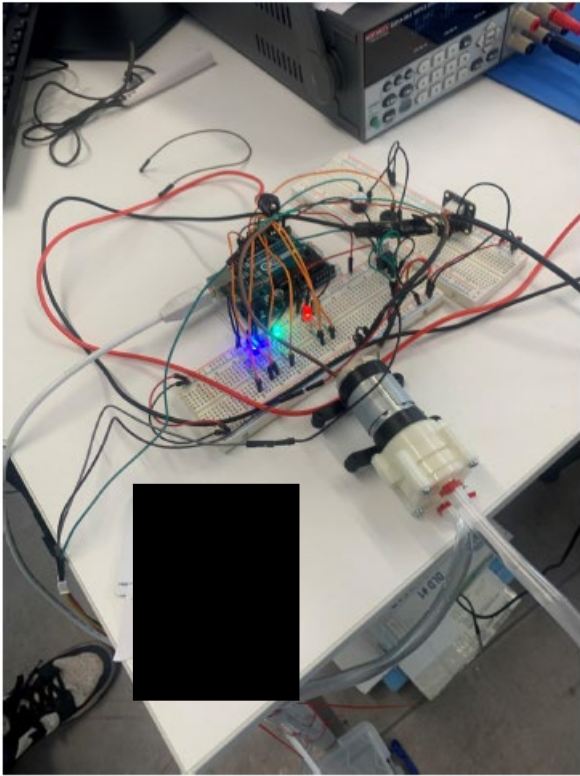
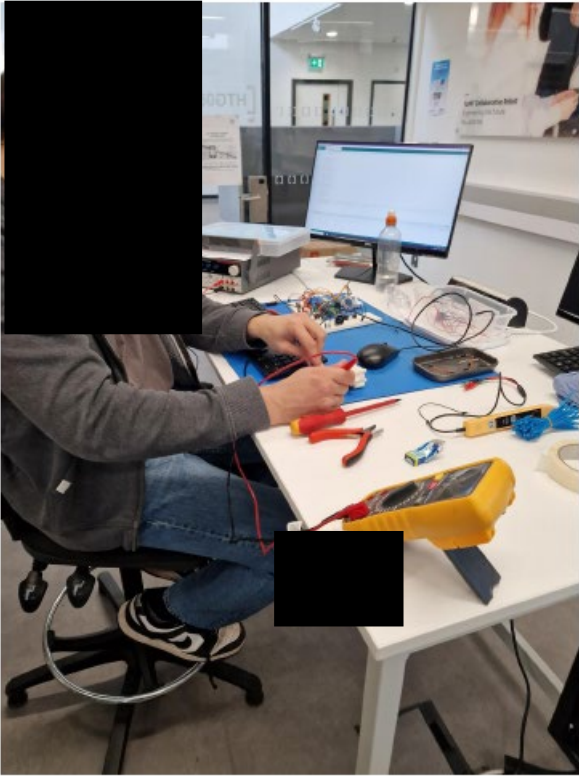

**Interfaces**

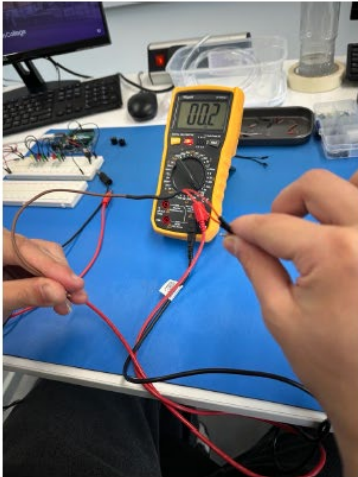
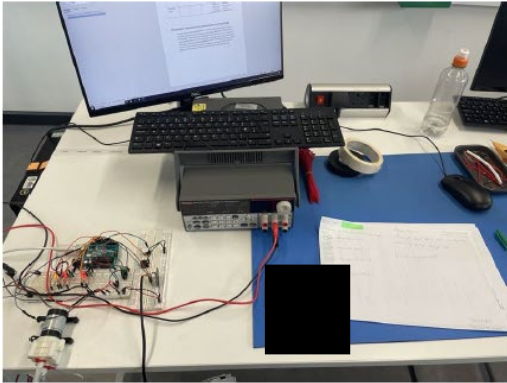

Sub-assemblies

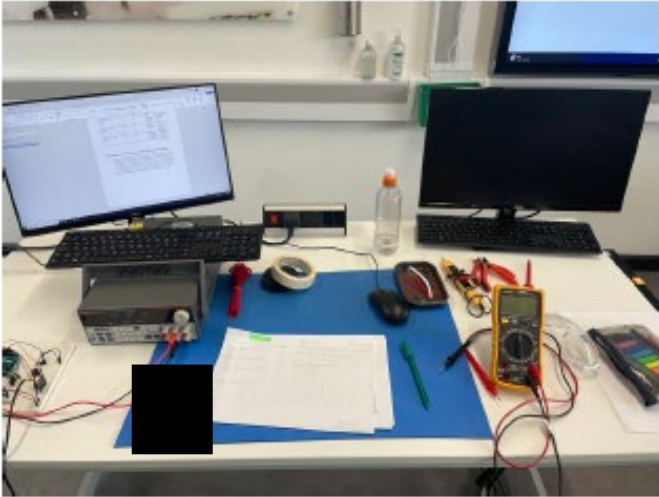
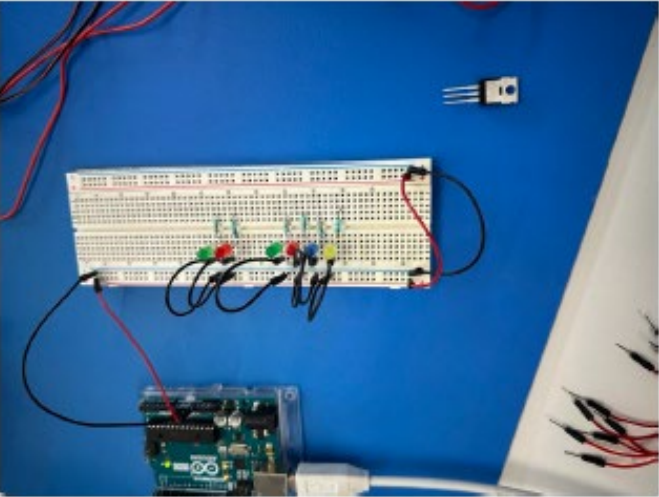
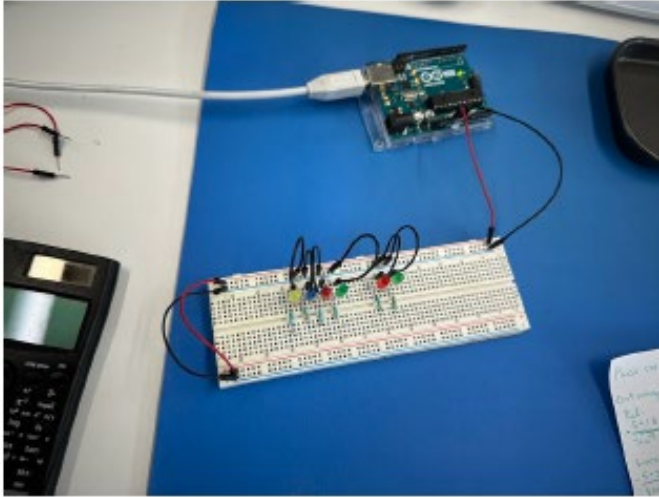

**Final Prototype**

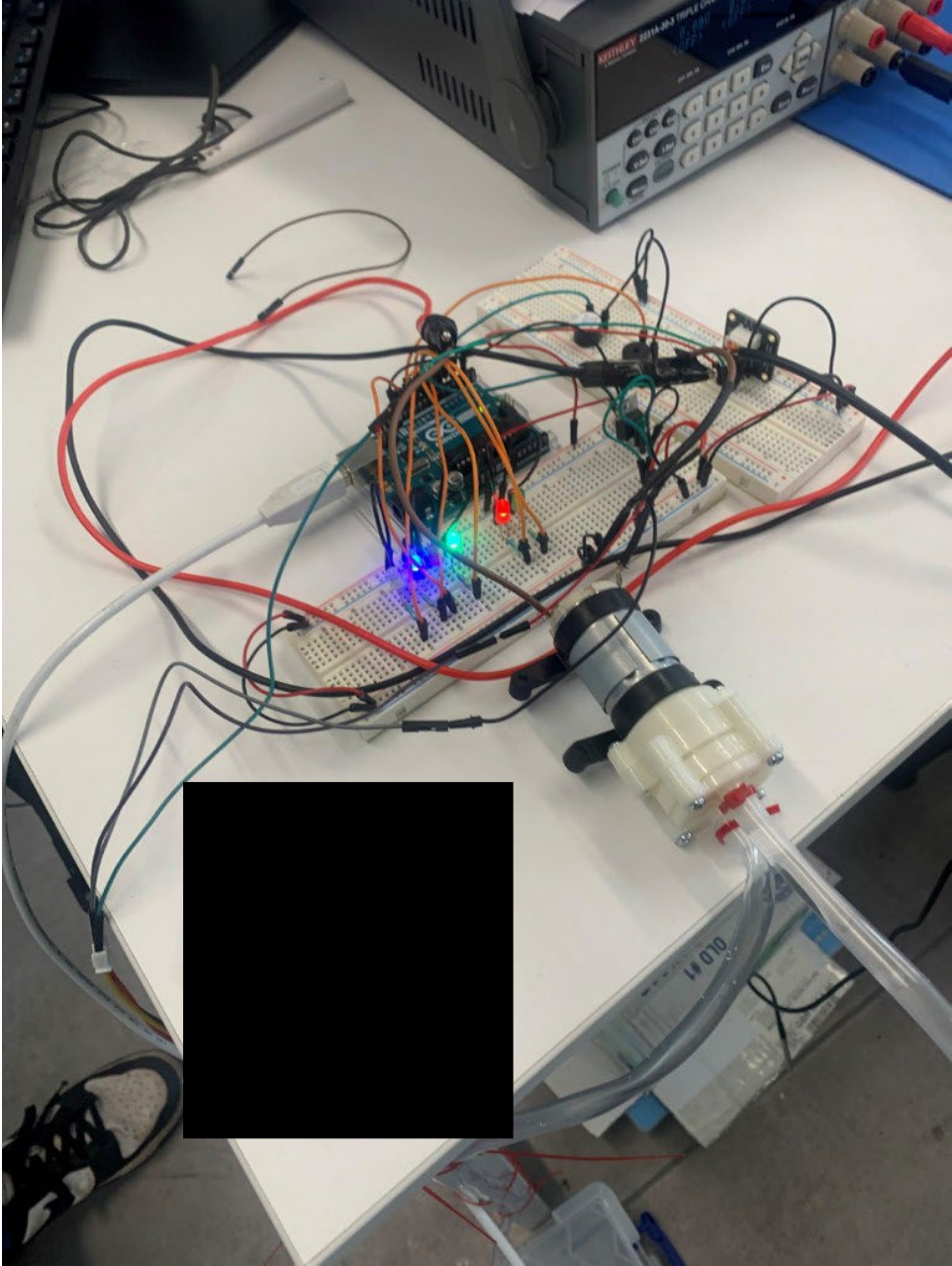

## Task 2 Practical observation form

8714-323 Design and Development: Control & Instrumentation - Summer 2025

<b>Candidate name</b>	<b>Candidate number</b>
<candidate>	ABC1234
<b>Provider name</b>	<b>Date</b>
<provider>	dd/mm/yy

Complete the table below referring to the relevant marking grid, found in the assessment pack.

**Do not** allocate marks at this stage.

This observation must cover	Assessor observation should include:	Assessment Themes
Manufacture and test	<ul style="list-style-type: none"> <li>• manufacturing of the prototype</li> <li>• testing and verification</li> </ul>	<ul style="list-style-type: none"> <li>• Health and Safety</li> <li>• Manufacturing</li> </ul>

**Notes** – detailed, accurate and differentiating notes which identify areas of strength and weakness are necessary to distinguish between different qualities of performance and to facilitate accurate allocation of marks once all evidence has been submitted.

**The manufacturing of the prototype:**

**Strengths:**

The candidate prepared the work area, with a clear and logical sequencing of tools and equipment on an electrostatic discharge (ESD) mat, technical documentation positioned to hand but not interfering with the workstation. Organisational boxes were used for effective assembly and a tidy working area (as shown in photographic evidence '*Tool selection and usage*' and '*Sub-assemblies*'). This is set in an electronics lab where the Health and Safety signage is already in place and appropriate. The candidate made a good selection of tools and test equipment needed to aid in completing the task. Manufacturing of the prototype was conducted in a safe manner, observing relevant health & safety regulations. The candidate worked neatly with good observance of keeping the workspace tidy and returning unused tools and equipment to the correct place. Excellent observance of ESD practices throughout. Good cable preparation skills were demonstrated, using correct tooling. Good soldering techniques were demonstrated and the candidate created a heat sleeved soldered joint. Wiring of input/output devices, subassemblies and interfaces was functional. The candidate could have made cabling neater, however, components were well laid out on breadboard. The candidate demonstrated a good approach to testing and verification testing the correct operation of each section of the design/interface devices individually before moving on and they used test equipment, such as a multimeter, to aid in testing various parts of the prototype.

**Weakness:**

The candidate left a tool behind at the solder station. They spent a long time testing the continuity of a cable with the multimeter set incorrectly, however, they worked the problem out for themselves. The candidate seemed to run out of time at the end which led to poor termination of some final connections.

**The testing and verification of the prototype:**

The candidate was able to demonstrate a working prototype, which was observed by the assessor, however, they did not provide a verbal explanation of the operation of the prototype with their final video.

Internal assessor signature	Date
X	dd/mm/yy

If completing electronically, double-click next to the 'X' to add an electronic signature once the record is **finalised**.

## Task 3 Peer review

<b>Assessment number (eg 1234-033)</b>	8714-323
<b>Assessment title</b>	Control and Instrumentation Occupational specialism

<b>Candidate name</b>	<first name> <surname>
<b>City &amp; Guilds candidate No.</b>	ABC1234

<b>Provider name</b>	<provider name>
<b>City &amp; Guilds provider No.</b>	999999a

<b>Task(s)</b>	3
<b>Evidence title / description</b>	completed feedback record form completed peer review feedback form.
<b>Date submitted by candidate</b>	DD/MM/YY

## Task 3

### Assessment themes:

- Reports

You must:

- a) prepare to present your design verbally using annotated sketches and diagrams
- b) present and explain the design
- c) peer reviewers will now have time to reflect on the design
- d) discuss feedback from the group on the design presented in part b)
- e) peer reviewers will now complete the peer review feedback form.

### Additional evidence of your performance that must be captured for marking:

None

## Candidate evidence

### Task 3 – Completed Feedback Record Form

<b>Assessment ID</b>	<b>Qualification number</b>
	8714-323
<b>Candidate name</b>	<b>Candidate number</b>
<candidate>	ABC1234
<b>Provider name</b>	<b>Provider number</b>
<provider>	
<b>Date</b>	<b>Series</b>
dd/mm/yy	Summer 25

<b>Candidate's notes</b>
<p>Is there a better way to visually display the temperature and flow rate from the sensors to the Viewer? I could have used an LCD display screen but it would overcomplicate the wiring management, however it does give the design a much more modern aesthetic.</p> <p>Is there a better way to display the circuit diagram to make it more approachable in terms on interpretation so that during presentation viewers can make more justified opinions. I could have used a more simpler circuit diagram approach so that the circuit diagram is more transparent.</p> <p>During the presentation I didn't turn on my circuit not because it wasn't operational it was because the conditions of the room in terms of temperature weren't correct for the circuit. If I did turn on the circuit one out would be displayed in terms of visual display which wouldn't prove my circuit is working at its fullest extent.</p> <p>During the manufacturing phase I chose not to use solder on the mounting points of the motor because if I did make a mistake, It would waste time in my manufacturing phase. And for the flow rate sensor hanging off the table I chose to use zip ties instead of brackets simply because it's a much less invasive mounting approach compared to zip ties.</p> <p>In my presentation I didn't place the circuit on the ESD protection mat since the circuit had ESD protection already. This is because I wanted to use the large surface area as a display area for my circuit diagrams and block diagrams so that the viewers can understand how I got to this conclusion of my design.</p> <p>If I were to make changes to my code, I would add more comments so that the code is easier to interpret when viewing the code or changing it. This would give the viewers more understanding of what my code does and there for giving them the opportunity to ask more questions since they now know how my code is laid out</p> <p>On my circuit the cable management wasn't the best and if I were to change this fact, I would add more zip ties and sturdy wires so that they can be strictly manipulated so that they are much neater and tidier so that they look more aesthetically pleasing and easier to interpret there for increasing its transparency.</p>

## Task 3 – Completed peer review form

<b>Assessment ID</b>	<b>Qualification number</b>
	8714-323
<b>Candidate name</b>	<b>Candidate number</b>
<candidate>	ABC1234
<b>Provider name</b>	<b>Provider number</b>
<provider>	
<b>Date</b>	<b>Series</b>
dd/mm/yy	Summer 25

<b>Question</b>	<b>Feedback</b>
Explain how well the diagrams/drawings meet the design criteria.	Drawings were efficient and displayed effectively and conformed to standards. The drawings also related to the criteria since they have drafts of the design approaches relating to the brief.
Explain how well the diagrams/drawings meet the specification criteria.	All the drawings were detailed and annotated very well and were relevant to the criteria.
Explain how well the diagrams/drawings conform to the relevant conventions.	Health and safety was shown in a risk assessment which was detailed and informative.
Explain how the system could be optimised/improved.	<p>Are there any other methods that the temperature and flow rate could have been displayed?</p> <p>Could the circuit diagram been less complex so that viewer scan interpret it more?</p> <p>Could you have shown the circuit operating during the presentation.</p> <p>During the manufacturing phase could you have been more proficient with the mounting techniques on the table?</p>

## Task 4 Evaluation and implementation

<b>Assessment number (eg 1234-033)</b>	8714-323
<b>Assessment title</b>	Control and Instrumentation Occupational specialism

<b>Candidate name</b>	<first name> <surname>
<b>City &amp; Guilds candidate No.</b>	ABC1234

<b>Provider name</b>	<provider name>
<b>City &amp; Guilds provider No.</b>	999999a

<b>Task(s)</b>	4
<b>Evidence title / description</b>	outcomes of virtual modelling revision control document evaluation and implementation report
<b>Date submitted by candidate</b>	DD/MM/YY

## Task 4

### Assessment themes:

- Health and Safety
- Design and Planning
- Reports

### You must:

- update the virtual model of your final design solution using appropriate software to incorporate any changes made and research completed in response to feedback or as a result of manufacturing and testing
- produce a revision control document or report that is typically 500 words, justifying why changes were made or not made as a result of the peer review feedback
- produce a report evaluating the design and development work completed. The report should typically be 800 words. This must include:
  - an explanation of the test methods used, reasons for your use and your limitations
  - an evaluation of the fitness for purpose of the design proposal and its conformance to the design criteria and specification
  - the information necessary for a third party to implement their design, including commissioning procedures and health and safety considerations
  - any further improvements or adaptations to the design including any reasoning, and justifications if adaptations or improvements are not required.

### Additional evidence of your performance that must be captured for marking:

None

## Candidate evidence

### Task 4 - Outcomes of virtual modelling

#### Virtual model for my design

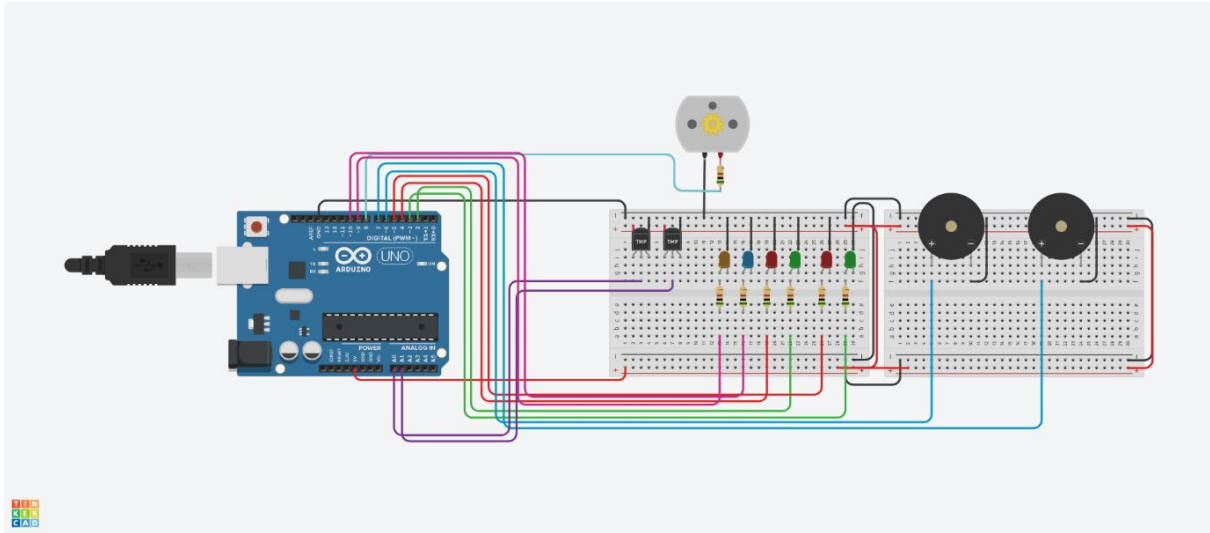

- I have not made any changes to my design in the virtual model because Tinker cad does not have the correct temperature sensor, nor does it have the Flow rate sensor so I'm going to continue using the TMP's as a demonstration of how the sensor would affect the circuits outputs if they were to change values. One strength on using the same design is that it allows me to save time on reconstructing a new design that better fits my manufactured design since the manufactured design uses different sensors. However, although this may be an advantage it is also a disadvantage since I cannot show the actual components on tinker cad since the website does not have the software for the components in my design. The reason this is a disadvantage is because I cannot show my virtual model of my design working with the actual components, I used there for making my virtual model invalid compared to my actual model which reduces its external validity to the real model. This is because the manufactured model uses the valid components needed to work in the real life setting whereas the virtual model wouldn't work on the outside because it has to temperature sensors mimicking the actions of the sensors I have used. This is a big disadvantage; however, it can be justified since tinker cad does not have the software I require.

Following on my feedback record form one of my peers said that there could be a better way of displaying the temperature readings and flow rate readings. I agreed with them and said that I could have used an LCD display screen to make my design more aesthetically pleasing in terms of modernity. But I also followed up with a point saying that the LCD display would over complicate my design and add an unnecessary number of wires to my circuit making it less interpretable. One advantage of not using an LCD display is that my LED's require much less wiring than an LCD display and relay the same information. This is an advantage because if my design requires less wiring to run it is there for more efficient because it requires less material to manufacture. Therefore TIMWOOD supports this design since it follows lean manufacturing techniques of using less material. Another advantage of using LED's is that LEDs are easy to maintain and fix since they only have one electrical pathway to check for continuity and can be easily connected to a circuit because they only have two

pins. This makes the implementation process faster and the maintenance easier making this product a lot more desirable to companies since the maintenance will be cheap and the parts to fix it will be cheap also. This is an advantage because companies will look for competitive prices on products with low maintenance since they want to increase profits and reduce deductions. Although, one disadvantage of not using an LCD display is that it will reduce the aesthetics of my design which will there for reduce the asking price of the product since other boilers will have a much more modern aesthetic since they have display screens. This is a disadvantage of my design since other boilers will have a higher chance of creating a market share in the boiler industry compared to my product since they have a much more desirable aesthetic than my boiler.

During my presentation I played out some circuit diagrams I drew out, these circuit diagrams followed electrical engineering standards and most of the class were mechanical engineering students. This then led to questions of the complexity of my circuit diagram and if there was a way to make them more transparent so that my peers can make more justified opinion on the design of my circuit diagram. One change I would implement onto my design diagrams would be a simpler circuit diagram so that my design is more interpretable. In hindsight it is my fault for producing industry standard circuit diagrams when I understood the fact that mechanical engineers will also be looking at my work.

### **Was there a better way to display the circuit diagram?**

Another point to add about my presentation was that I didn't turn on the circuit during the presentation, and one of my peers picked up on this and asked me why I didn't turn it on. This was because my circuit runs of temperature readings and flow rate readings. I couldn't show the temperature sensor working because the room was already at 18 degrees Celsius which meant only one part of my circuit will turn on. This doesn't prove that my circuit is working at its fullest extent since one operation of my circuit is being presented. I didn't have any set conditions such as Hot water Room temperature water and Cold water on standby to test all conditions. This is what led me to the conclusion of not showing my circuit during operations. However, I could have presented the flowrate sensor working and I am ashamed I didn't come to this conclusion because I could have shown three operations of my circuit with the flow rate sensor which would show my circuits flow rate system working at its fullest. One change I would have made during my presentation would have been demonstrating that my flowrate sensor does have an impact on my circuits outputs and that they are all correct.

### **Could you have been more proficient with mounting your pipes and wires to the table legs during manufacturing?**

- I replied to this question with the following, I used zip ties to mount the wiring and tubes to the table legs during the manufacturing phase since it is a much less invasive approach compared to using mounting brackets. The use of brackets for a prototype is unjustified since I am not building a permanent product and it destroys the table that is used for learning. I think the use of zip ties was more efficient since it can be taken of with clippers and doesn't destroy the table whatsoever.

### **ESD protection to the Arduino?**

- During my presentation a peer asked why my Arduino isn't placed on the ESD matt when I was presenting, I replied with the following. The Arduino has a plastic ESD cover on the bottom so that it is protected without the use of a ESD matt, also the breadboard will protect the mosfet from ESD harm since the breadboard material has an insulated cover on the

bottom protecting all components on it from ESD harm. The reason I didn't place my components on the ESD matt during presentation was because I was using it as a display form. for all my diagrams and drawings so my peers can understand how I got to my design and the following steps I made to get to this conclusion. Although the components were protected it didn't look neat to have them on the side of the table during my presentation. Because of this question were asked on why my circuit was not turned on or place on the ESD matt. So, one change I would have made during my presentation was finding the space to place the Circuit on the ESD matt ready for operation and my diagrams orbiting the circuit so that this question can be avoided, and further questions can be expanded upon.

**On the prototype could you have managed your wiring a little better?**

- One my peers asked me this question so I replied with the following, I could have managed the wiring a lot better if I had the given time to do it. One change I would have made if I had the time was to make the wires all managed in rows together in there colours so that it looked very neat for the presentation, but I did not have time for that since most of my time was spent on the code itself. And because of the time I spent on the code I was unable to make the wiring neater there for question were arrested from that mistake I made of which I am ashamed for.

## Task 4 - Revision control document

- One change I would have made on my design was the use of a LCD display screen this is because one of my peers pointed out if there was a better way to display the sensor readings. This is because it looks more complex and gives my design a more modern look which makes it more desirable. One change I didn't make to my design was moving the circuit onto the ESD matt, this is because the components already had ESD protection in the beginning which is why I used the ESD matt as a display area for my design and what choices I made to get to my concluded design. This is justified by the fact that my components already had ESD protection so placing it on the matt wouldn't be justified but using it as a display area is since my peers can gather around my diagrams easier if there all spread out which is why I didn't place my circuit on the ESD matt.

- Another justified action I chose was to use zip ties to mount my tubes and wiring to the table legs so that my tubes can reach the floor during testing. This is because there was a jug of water with a control temperature so that my circuit can operate within a closed loop during testing so no external variables and affect the reliability of my results and the validity of my testing method. One of my peers asked if I can have used a more proficient mounting method and, I replied with the following. I chose to use zip ties since they are a lot less destructive compared to mounting brackets since brackets require drilled holes to mount onto structures. Therefore, that's why I think the use of zip ties is justified within my prototype design. Zip ties are also easy to take off and replace which is a strength for my design in its prototype phase since I need to make quick changes to reduce time and increase efficiency compared to brackets that require a lot more time to take apart and replace and take more time to mount onto a structure compared to a zip tie. This is also why I think zip ties are a more justified option compared to mounting brackets.

- One change I would have liked to make to my prototype is tinning the motors electrical mounts to the wires so that they have a stronger connection the chances of them being ripped apart are dramatically reduced. The reason I didn't tin them during my manufacturing phase was because I wanted to make sure I could take the wire apart from the motor if made a mistake with the wiring. This was a strength during the manufacturing phase however, once I got the wires to the motor connected, I should have tinned the wires to the motor, so the wire connection is more permanent. That's why my choice to make a change to the tinning of the wire connection to the motor is justified because it is safer, and a much more permanent secure wiring connection compared to knotting it.

## Task 4 - Evaluation and implementation report

### Evaluating Testing methods

- To test my circuit worked I used 3 conditions that were relevant to the brief One of the conditions were hot water that would be cycled through the circuit to demonstrate what the circuit will output if the circuit was hot. One advantage of this approach is that is high internal validity because the circuit runs of a closed loop system there for increasing internal validity. However, one disadvantage of this testing method is that it lacks high external validity because the water isn't contaminated and in a real life setting the water could have other contaminants affect the specific heat capacity of the water there for taking either shorter or longer amounts of time to cool down the water. The reason this is a disadvantage is because we can't guarantee how fast the water will cool down or heat up since we don't know the specific heat capacity of the water in that area since it could have different contaminants. However, having low external validity is a disadvantage. It can also be an advantage because having high internal validity in the testing method reduces external validity dramatically and increases the reliability of the results while also increasing the validity of the results there for making the testing method not only reliable but controlled and validated.

The second condition was room temperature water which ran through the system in a closed loop system like condition one. These conditions are used to satisfy the brief and show that my circuit meets the specifications in terms of visual and audio outputs in certain parameters such as room temperature in condition one. One advantage of using room temperature water for condition two is that it relates to the brief there for making it relevant but it also increases the accuracy of my testing method since the water will be at room temperature so the testing method should have no external variables interfering with the results which make the results high in validity and reliability. For the data format of the results, we gathered I took a holistic approach since I used quantitative and qualitative data to show empirical proof that my circuit does work. The data is qualitative because a video was taken during all three conditions during operation to show that the circuit is working in real time. The data is also quantitative because the serial format in my code displays the flow rate of the water within the closed loop and the temperature of the water within the closed loop ever half second. This is an advantage because my data format takes a holistic approach to gathering data there for showing all potential causes of interference and increasing the accuracy of my data since all potential variables have been taken into consideration within my data gathered. However, one disadvantage of using a holistic approach to gathering data is that it takes more time to gather and takes more time to sort and store since all variables are being considered. However, this is justified because the data gathered there for can show more empirical evidence that my circuit works.

For the third condition I used cold water to demonstrate how my circuit will react If cold water is brought into the closed loop system. The use of cold will show empirical evidence that my circuit does work will cold water also, because cold water was introduced and recorded in real time to see what my circuit does.

### Conformity to the specification evaluation

My design conforms to the specifications of the brief perfectly since it runs on a closed loop with visual and audio displays on when the circuit is working within or out of bounds in terms of temperature and flow rate. My design also displays temperature and flow rate values within the serial code itself for maintenance. One advantage of my design is that it displays temperature, and this is an advantage because it conforms to the specifications set by the brief there for making the temperature display valid. Another advantage of my design is that it

can display the flow rate value through the use of 2 LEDs, one for flow\_rate\_positve and another for flow\_rate\_negative the values will let the user know if there is flow rate within the closed loop or not which is an advantage for my design because it conforms to the projects specifications given out the brief there for making my flow rate sensor LEDs valid. Although, one disadvantage of my design is that I could have used an LCD display screen to show both flow rate and temperature within the same component rather than having 4 LEDs. This is a disadvantage because the use of an LCD display is more aesthetically pleasing in terms of modernity and more efficient at housing more sensor values compared to using 4 LEDs. Another advantage of my design is that I have a visual display of when the circuit is heating up or cooling the water, 2 LEDs do this job, and this gives the user the ability to interpret when the water is colling down and the water is heating up. This is an advantage because it conforms to the specifications set by the brief and informs the user when the circuit is heating up or colling down there for making the colling down and heating up LEDs valid.

### **Health and safety evaluation**

- In my design phase I constructed a risk assessment for implementation for my prototype for when it becomes a product. One advantage of this is that follow industry standards set by HSE regulations and conforms to the specification set by the brief there for making the risk assessment valid. One other advantage of my implementation phases safety standards is that the workers will be using insulated tools to protect themselves from electrical harm. This is an advantage because not only does it conform to HSE rules and regulations on the health and safety at work act, but it also protects our workers while giving them the correct tools to finish the job effectively and safely.

## Principal Moderator Commentary

The candidate used basic CAD tools to produce diagrams that showed the system layout. While functional, the diagrams lacked detailed annotation, and some symbols were not industry standard. The evidence shows the candidate could operate the software but only to a basic level.

The prototype was assembled and functioned broadly as intended, but connections were not always secure and required minor correction by the assessor to meet specification. The candidate followed the method statement but with occasional inefficiencies, showing developing but limited technical skill.

The candidate demonstrated a developing knowledge and understanding of testing processes by carrying out basic continuity and voltage tests, recording values on the test sheet. However, not all parameters were measured, and tolerances were sometimes left uncalculated. The prototype was checked against key criteria (power restored, HMI display active), but some aspects (e.g. calibration of sensor output) were less rigorously tested.

The candidate produced a method statement that was sequential but lacked full justifications. The risk assessment identified the main hazards (electric shock, slips, tool handling) but mitigations were generic. During practical work, the candidate followed safe isolation correctly and wore PPE throughout, demonstrating acceptable standards of safety.

The candidate understood the need for safe isolation and component replacement, applying design knowledge at a basic level. For example, the candidate replaced the fuse and transmitter to restore system function, but they did not extend their analysis to future preventative measures or alternative design solutions.

The candidate demonstrated an understanding and suitable level of awareness in the preparation and application of processes, choosing and handling tools and components safely and appropriately, selecting the correct screwdriver, crimping tools, and meter. Minor errors were observed — such as a loose termination that had to be re-secured — but overall, the work was safe and acceptable for a pass standard.

The candidate used many technical terms correctly in their written report, such as isolation, calibration, continuity check, though occasionally terminology was vague (e.g. “the wire thing was replaced” instead of “conductor terminated”). During the handover, the candidate’s communication was generally clear, with some imprecise phrasing that limited professionalism but remained understandable.

## Get in touch

The City & Guilds Quality team are here to answer any queries you may have regarding your T Level Technical Qualification delivery.

Should you require assistance, please contact us using the details below:

Monday - Friday | 08:30 - 17:00 GMT

T: 0300 303 53 52

E: [technicals.quality@cityandguilds.com](mailto:technicals.quality@cityandguilds.com)

W: <http://www.cityandguilds.com/tlevels>

Web chat available [here](#).

The T Level is a qualification approved and managed by the Institute for Apprenticeships and Technical Education.

Copyright in this document belongs to, and is used under licence from, the Institute for Apprenticeships and Technical Education, © 2025. 'T-LEVELS' is a registered trade mark of the Department for Education. 'T Level' is a registered trade mark of the Institute for Apprenticeships and Technical Education. 'Institute for Apprenticeships & Technical Education' and logo are registered trade marks of the Institute for Apprenticeships and Technical Education.

We make every effort to ensure that the information contained in this publication is true and correct at the time of going to press. However, City & Guilds' products and services are subject to continuous development and improvement, and the right is reserved to change products and services from time to time. City & Guilds cannot accept responsibility for any loss or damage arising from the use of information in this publication.

City & Guilds is a trade mark of City & Guilds Limited (Reg No 16513878). City & Guilds, Giltspur House, 5–6 Giltspur Street, London, EC1A 9DE.