



HM Government

T-LEVELS

**T Level Technical Qualification in
Design and Development for
Engineering and Manufacturing
(8714-33)**

**Occupational Specialism in
Control and Instrumentation
Engineering (323)**

**Guide Standard
Exemplification Material
Distinction**

**City
& Guilds**

eal

First teaching from September 2022

Version 1.2

Version and date	Change detail	Section
1.1 January 2023	Formatting of Task 1 evidence requirements	Task 1
1.2 March 2026	Minor amendment to first paragraph	Introduction

Contents

Introduction	3
Grade descriptors	4
Task 1 – Design	5
1a) <i>Design specification</i>	6
1b i) <i>Annotated sketches, block and wiring diagrams</i>	8
1b ii-iii) <i>Options for the sensors and pre alarm temperatures with justifications, and calculations</i>	10
1c) <i>Outcomes of the virtual modelling</i>	15
1d) <i>Bill of materials</i>	17
Task 2 – Manufacture and test	20
2a) <i>Risk assessment</i>	21
2b) <i>Manufacture of the prototype</i>	23
2c) <i>Testing and verification</i>	29
Task 3 – Peer review	33
<i>Peer review feedback form</i>	34
Task 4 – Evaluation and implementation	35
4a) <i>Outcomes of virtual modelling</i>	36
4b) <i>Revision control document</i>	37
4c) <i>Evaluation and implementation report</i>	40

Introduction

The Guide Standard Exemplification Material within this document refers to the T Level Technical Qualification in Design and Development for Engineering and Manufacturing - Occupational Specialism in Control and Instrumentation Engineering sample assignment. The aim of these materials is to provide centres with examples of knowledge, skills and understanding that attest to distinction competence. In this document all exemplar evidence attests as examples of performance at the distinction grade boundary. The examples provided do not reflect all evidence from the sample assignment as the focus of this material is the quality and standards that need to be achieved rather than the volume of exemplar evidence provided. However, the examples provided are representative of all tasks in the sample assignment. The evidence presented here has been developed to reflect a distinction grade within each task but is not necessarily intended to reflect the work of a single candidate. It is important to note that in live assessments a candidate's performance is very likely to exhibit a spikey profile and standard of performance will vary across tasks. A distinction grade will be based on a synoptic mark across all tasks.

The materials in this Guide Standard Exemplification Material (GSEM) are separated into three sections as described below. Materials are presented against a number of tasks from the assignment.

Task

This section details the tasks that the candidate has been asked to carry out, what needs to be submitted for marking and any additional evidence required including any photographic evidence. Also referenced in this section are the assessment themes the candidates will be marked against when completing the tasks within it. In addition, candidate evidence that has been included or not been included in this GSEM has been identified within this section.

In this GSEM there is candidate evidence from:

Task 1

Task 2

Task 3

Task 4

Candidate evidence

This section includes exemplars of candidate work, photographs of the work in production (or completed) and practical observation records of the assessment completed by centre assessors. This will be exemplar evidence that was captured as part of the assessment and then internally marked by the centre assessor.

Commentary

This section includes detailed comments to demonstrate how the candidate evidence attests to the standard of distinction competence by directly correlating to the grade descriptors for this occupational area. Centres can compare the evidence against the performance indicators in the marking grid descriptors within the assessor packs, to provide guidance on the standard of knowledge, skills and understanding that need to be met for distinction competence.

It is important to note that the commentary section is not part of the evidence or assessment but are evaluative statements on how and why that piece of evidence meets a particular standard.

Grade descriptors

To achieve a distinction, a candidate will typically be able to:

Demonstrate a comprehensive use of software / technologies to model, evaluate and produce engineering diagrams and simulations that meets the requirements of the brief.

Demonstrate excellent technical skills when developing models and prototypes, resulting in a model that is fully functional.

Apply comprehensive knowledge and understanding of testing processes, resulting in a model that has been tested against all of the design criteria.

Critically interpret information to plan, assess risk, follow safe working practices and apply the technical skills to practical tasks and procedures to an exemplary standard in response to the requirements of the brief, producing an excellent quality of work.

Apply comprehensive knowledge and understanding of the design principles required for control and instrumentation resulting in proposals and solutions that meet all requirements of the brief.

Work safely and make well founded and informed decisions on the selection and appropriate use of tools, materials and equipment within the environments that they are working in, resulting in tasks that are carried out to a high degree of accuracy.

Use accurate industry and technical terminology consistently in both written and verbal contexts.

Task 1 – Design

(Assessment themes: Health and safety, Design and planning)

For task 1, candidates need to produce the following pieces of evidence:

- a) design specification
- b)
 - i) annotated sketches, block and wiring diagrams
 - ii) design options for the sensors with justifications, and calculations
 - iii) selection of appropriate pre alarm temperatures with justifications and calculations, including all workings
- c) outcomes of the virtual modelling of the proposed system design, either as screen captures or printouts
- d) bill of materials.

For Task 1, the following additional evidence may also be submitted:

- any notes produced of research undertaken including citation of sources and internet search history.

1a) Design specification

Candidate evidence

Design requirements:	How the requirements will be met:
<i>Automatic monitoring and regulation of temperature and lighting within the process.</i>	By implementation of a system using a PID (proportional, integral, derivative) controller, the requirements can be met. The PID controller will use the information from the sensors to maintain the setpoints. The PID will automatically calculate the error, feeding back the measurement and allowing the smart sensors to alter as required when connected to the heating and cooling system. I therefore believe that the use of a PID controller supports a high degree of accuracy that supports a high level of confidence in identifying issues and therefore supports a greater level of system stability.
<i>Temperature control system must not exceed three overshoots on first switching on from a 30°C start.</i>	The PID controller aids with overshoot issues and the reduction of overshoot through derivative control. The controller will automatically calculate and adjust the proportional and integral as required.
<i>Temperature alarm when range limits are nearing.</i>	Sirens/sounders to be installed into a control panel and alarm when the range limits are approaching. This will be calculated to ensure sufficient notice is given to users that the system is reaching the upper/lower temperature limits. This will allow for problems and issues with the process to be addressed before the actual alarm limits are reached. Lights will also be introduced to illuminate at the same time as the alarm sounds. This will allow for visual indication as well as audio indication, should the sounders fail at any point, thereby providing a fail-safe to support control of the system.
<i>Visual display of the lighting and temperature levels in real time.</i>	VDU (Visual Display Unit) to be installed onto the panel. The VDU will allow for the state of the control system to be displayed and any error messages or faults to be presented. The VDU will allow for the constant display of the measurements in real time, as readings from the sensors will be constantly sent. The VDU may also enable access to the parameters and set points. The VDU will accommodate remote monitoring and evaluation of the process should the user wish.
<i>Recording of the parameters.</i>	Depending on the selected user interface, the parameters of the system can be stored and accessed. It is important that a method of recording parameters is utilised so that all historic readings and parameters can be obtained and analysed as required. The parameters will need to be accessed for system performance reasons and maintenance requirements.
<i>Changing of set points for different applications and processes.</i>	Selecting the PID controller as the design solution allows for the setpoints to be easily changed and calculated which will enable the system to be changed as per the process for the future requirements.

<p><i>Detection of light level below 10,000 lux.</i></p>	<p>The sensor that is selected must have a range that will allow for the 10,000 lux limit to be detected when light levels drop under this value.</p> <p>The sensor chosen must have the capacity to be controlled by the automatic system and PID controller.</p>
<p><i>Health and safety</i></p>	<p>Health and safety will be a consideration throughout and will be managed by having thorough risk assessments and following the manufacturer's instructions when using the different tools, equipment and components.</p> <p>Health and safety regulatory requirements to be adhered to include, Health and Safety at Work Act, Provision and Use of Work Equipment Regulations, Personal Protective Equipment Regulations and Electricity at Work Regulations.</p>

Commentary

The candidate has produced a comprehensive and thorough design specification, which covers all points of the design criteria and a range of additional points, such as providing some relevant health and safety regulations that will be adhered to. Most points have been elaborated on in detail, for example the explanation of the visual display unit includes details on how the system will be able to display outputs of measurements in real time and allow access and viewing of the parameters and set points. The candidate has demonstrated additional benefits, such as the VDU being accessible remotely – which would be beneficial when users are not present on-site.

The candidate's knowledge and understanding for each element of the design is demonstrated through the detailed justifications of the selected components and equipment, for example providing details on how the chosen components will meet the requirements for the design specification, such as the integration of sirens and sounders to indicate when the pre-alarms and alarms have been reached.

The candidate shows a detailed knowledge and understanding of the process, including a range of relevant areas and additional factors, such as how the PID (proportional, integral, derivative) controller will calculate errors using the desired setpoint and measured variable. To develop the response even further, the candidate could have explained that this value is then used to calculate the overshoot.

Candidate evidence

1b i) Annotated sketches, block and wiring diagrams

Annotated sketches

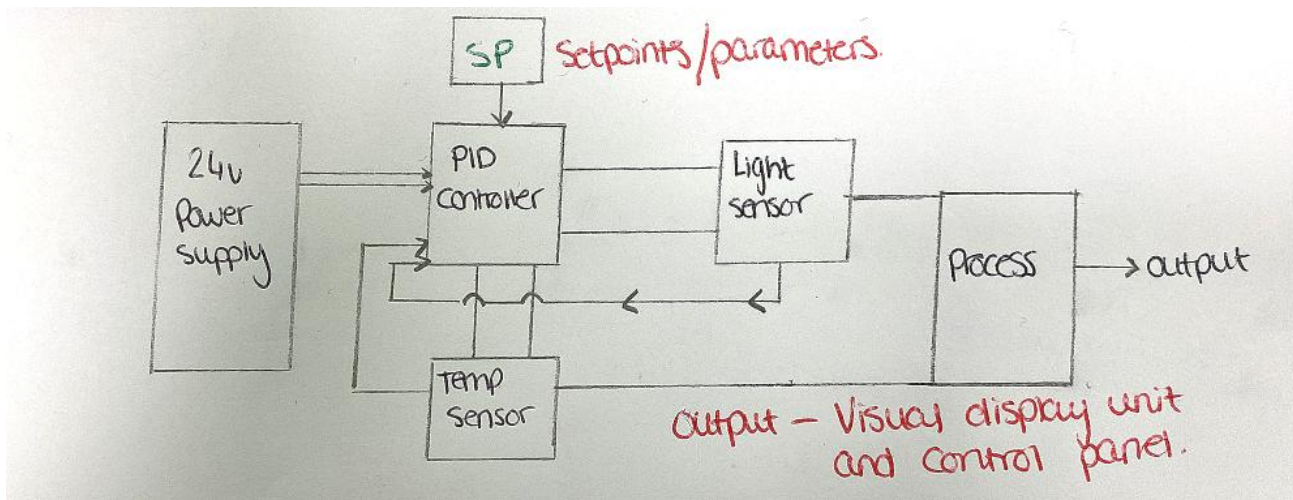
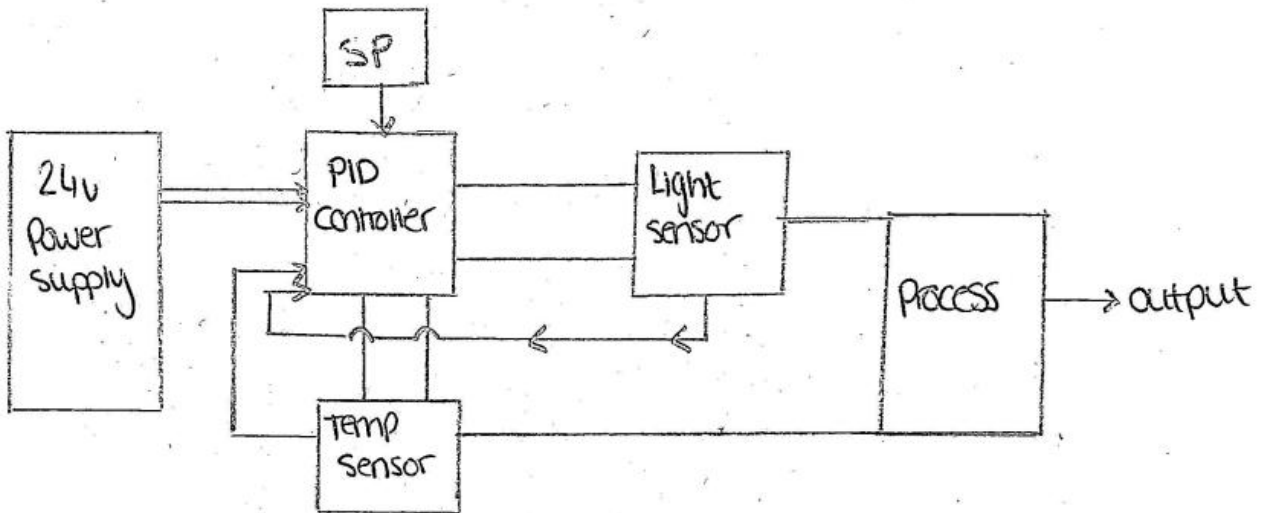

Block diagram

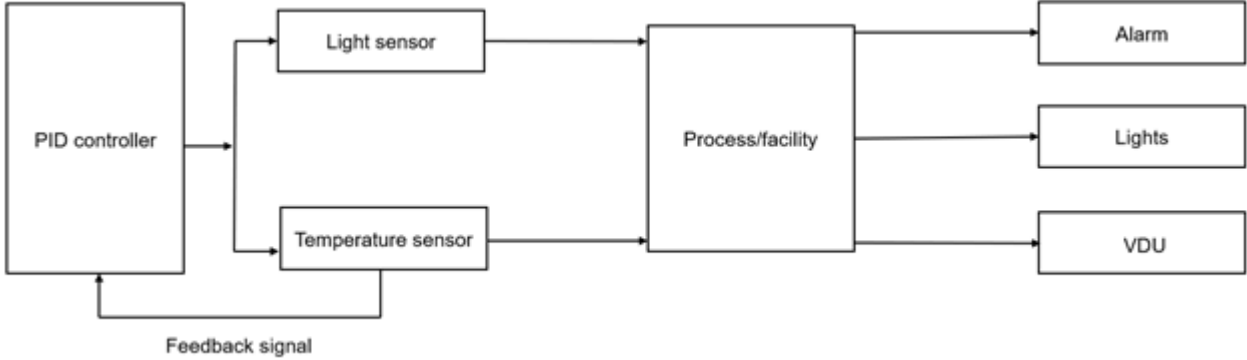

Wiring diagram

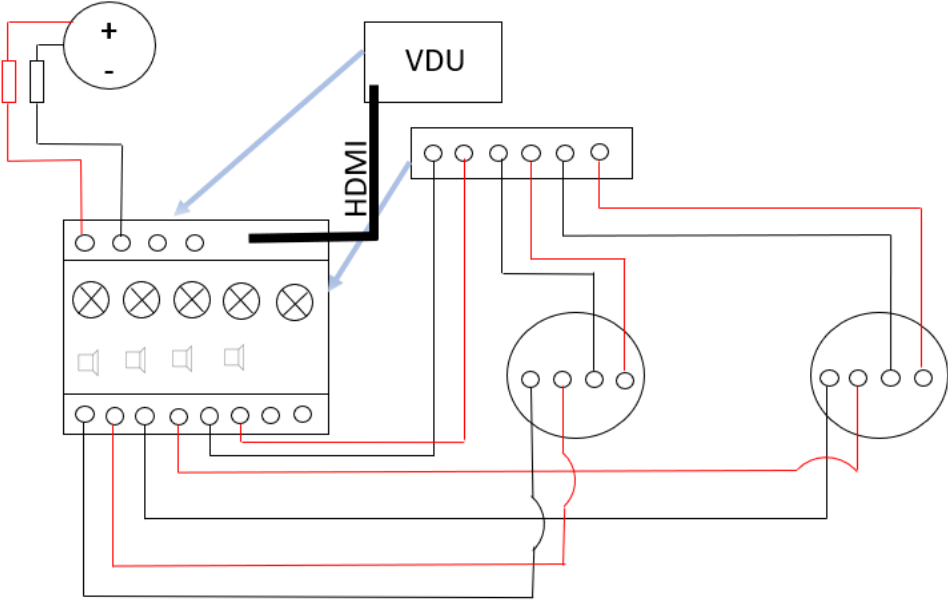

1b ii-iii) Options for the sensors and pre alarm temperatures with justifications, and calculations

Light sensor: LXT-TRM

Specification

www.pce-instruments.com/english/measuring-instruments/test-meters/light-meter-pce-instruments-light-meter-lxt-trm-det_387204.htm



Description

- Transmitter unit
- Measuring range 0-500,000 lux
- 4-20mA output and control relay

Calculations

The datasheet for this sensor shows that it has a tolerance of +/- 3% for the measurements taken.

For example, for a reading of 10,000 lux:

Maximum possible value = $10,000 + (10,000 \times 0.03) = 10,300$ lux

Minimum possible value = $10,000 - (10,000 \times 0.03) = 9,700$ lux

Benefits

Can be mounted in the area for constant monitoring of the light levels due to the capabilities of measuring light across sufficient distances.

The measurement range will allow for the adjusting of the different processes and different limits to be set depending on the process.

The sensor has a long measuring probe which will allow for the position of the sensor to be moved if required.

The sensor is approved for facilities such as the environment and process discussed in the assessment brief.

Justification

Overall, the sensor provides an ideal option for the design solution.

Reviewing the calculations and expected parameters, whilst it is not ideal that an exact measurement cannot always be made, this sensor provides a very reasonable level of tolerance given the requirements of the brief, i.e. when the sensor detects the light levels have dropped below 10,000 lux. Even at the minimum lux value of 9,700 it is very unlikely that any damage would be caused to the produce before the issue is reported.

Additionally, the wide measurement range provided by this sensor means that, if different parameters need to be set for different produce, then this sensor will be able to be reconfigured to support that change in parameters. This makes it a versatile option for the facility – and wouldn't need to be replaced if the light tolerances need to be altered.

The sensor is also recognised as being approved for a facility where food production is occurring. This is important as it means that it contains no parts that can fall off or be dislodged, that may become a contaminant for the produce.

Temperature sensor: TES PT1000

Specification

SN1.06-Tes.fm (syxthsense.com)



Product sheet **SN1.06**

Sensor type **TES**

Sauna Temperature Sensors

for HVAC & refrigeration systems

TES temperature sensors are designed for automatic HVAC and refrigeration systems, especially for demanding conditions such as saunas, cold-rooms, freezers and stores.

Housing is made of weather-proof aluminium, IP 67, which also ensures good mechanical durability for the sensor.

Temperature is detected by a range of thermistors and resistive elements with nominal resistances (see table overleaf). Thermistor is outside the housing.



Description

- Measuring range of -50°C to 120°C
- Mechanically durable which suits the environment of the facility
- Suitable for the application

Calculations

The resistances at the maximum and minimum temperature regulation range values given in the design criteria are calculated as follows:

At 18°C:

$$t_1 = 18 + 273.15 = 291.15^\circ\text{C}$$

$$t_2 = 25 + 273.15 = 298.15^\circ\text{C}$$

$$3455 = \ln (R_2 / R_1) \times (t_2 \times t_1) / (t_1 - t_2)$$

$$3455 = \ln (10000 / R_1) \times (298.15 \times 291.15) / (291.15 - 298.15)$$

$$3455 = \ln (10000 / R_1) \times -12401$$

$$e^{[3455 / -12401]} = 10000 / R_1$$

$$\text{So } R_1 = 10000 / e^{-0.279}$$

$$R_1 = 13213 \, \Omega, \text{ or } 13.2 \, \text{k}\Omega \text{ at } 18^\circ\text{C}$$

At 24°C:

$$t_1 = 24 + 273.15 = 297.15^\circ\text{C}$$

$$t_2 = 25 + 273.15 = 298.15^\circ\text{C}$$

$$3455 = \ln (R_2 / R_1) \times (t_2 \times t_1) / (t_1 - t_2)$$

$$3455 = \ln (10000 / R_1) \times (298.15 \times 297.15) / (297.15 - 298.15)$$

$$3455 = \ln (10000 / R_1) \times -88595$$

$$e^{[3455 / -88595]} = 10000 / R_1$$

$$\text{So } R_1 = 10000 / e^{-0.039}$$

$$R_1 = 10398 \, \Omega, \text{ or } 10.4 \, \text{k}\Omega \text{ at } 24^\circ\text{C}$$

Benefits

The measuring range of the sensor is outside the requirements of the specification in the brief so will therefore function efficiently on the setpoints provided.

The measuring range is wide so will allow for process changes and setpoint changes.

External thermistors so the sensor can be mounted above the process and will continuously measure the temperatures.

Justification

This sensor is a very good option for the requirements of the design.

The chosen temperature sensor makes use of 10 k Ω at 25°C negative temperature coefficient (NTC) thermistors within the main sensor element. The specified B (beta) value is 3455 for this type of thermistor.

The calculated values can be measured against during testing of the functionality of the finished system. The increase in resistance vs the decrease in temperature (and vice versa) can clearly be seen in the calculations at the two temperature points.

Additionally, the wide temperature measurement range that this sensor is capable of means that, if different parameters need to be set for different types of produce, then this sensor will be able to be reconfigured to support that change in parameters. This makes it a versatile option for the facility – and, like the light sensor, it wouldn't need to be replaced if the temperature tolerances need to be altered.

Pre-alarm temperatures: Piezo Siren SP6210

Specification

www.jprelec.co.uk/categories/electro-mechanical/speakers-sounders/piezo-siren-sp6210/product/piezo-siren-sp6210/400-010~400-010



Description

- Output: 105 dB
- Temperature range: -20°C to +60°C

Benefits

A piezo siren, such as the one pictured, will be used to provide the audible output for the pre-alarm. This specific siren has been selected because it provides a loud output, which would be heard in the manufacturing area.

This siren also has a suitable working temperature range for the environment in which it will be used, which means it can be used for other applications should the process requirements change in the future.

When the set pre-alarm temperature is reached, the LED/bulbs will illuminate to indicate the setpoints are almost reached.

The visual indication/warning will allow for the process to be addressed before the audio alarms sound.

Commentary

The block diagram produced shows a detailed overview of the system with the individual subsystems and how they connect. The signal flow and feedback loop are shown using the correct conventions. This results in a clear visual representation of the proposed design.

The wiring diagram produced is clear and provides details of how the components are connected to each other. The candidate has considered almost all the requirements for the circuit, for example included the power supply, fuses and HDMI (High-Definition Multimedia Interface) cable for the connection of the VDU (Visual Display Unit). The candidate has indicated clearly that the VDU and controller will be located within the panel. To develop the response even further, the candidate could have produced a specific wiring diagram for the pre alarm and alarm circuit, although they have considered these and indicated their position within the panel. The candidate has used the correct industry coloured wiring for control and instrumentation processes, to represent the connections.

Appropriate sensors have been selected, described, and justified with reasoning that shows how each sensor meets the requirements of the brief and specification. The candidate has included technical data, for example the ranges that the sensors work within. They have also included links for the data sheets which demonstrates they have viewed and analysed the information. The candidate's response includes detailed justifications that reflect how the features of each sensor would be advantageous for the design solution. For example, recognition that the sensor range will ensure that tolerances can be identified, and also changed as and when needed.

The candidate has undertaken a range of thorough calculations to determine the required ranges for both the temperature and light sensors, to meet the design criteria. The calculations are detailed and accurate, displaying clear use of the correct methodology.

1c) Outcomes of the virtual modelling

Candidate evidence

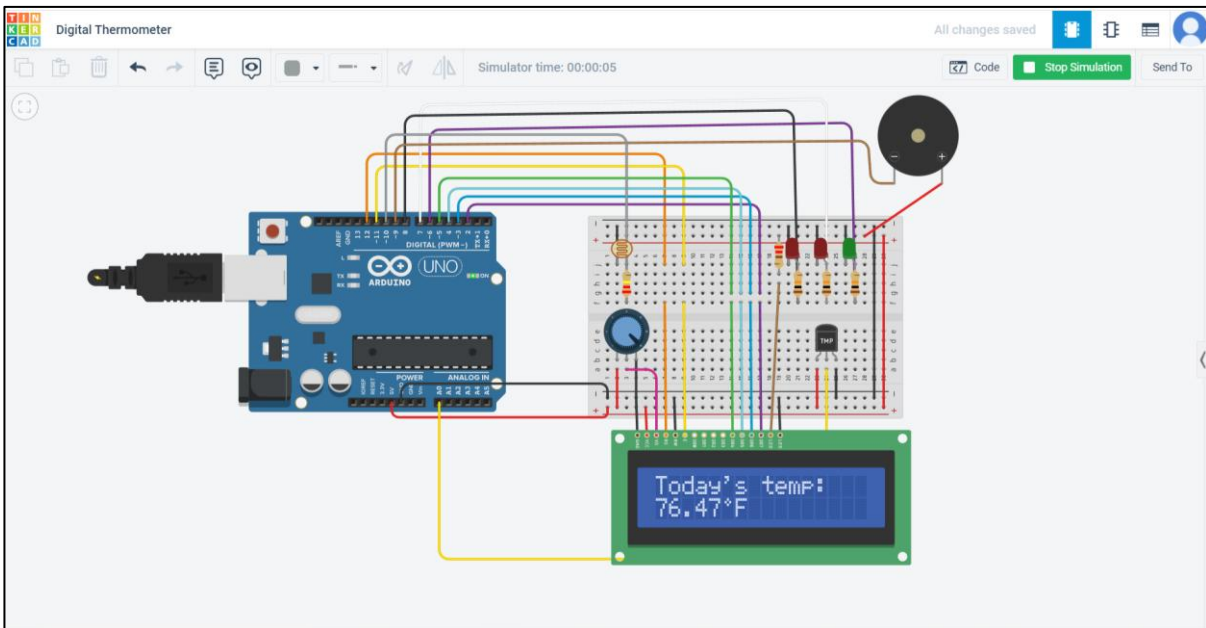
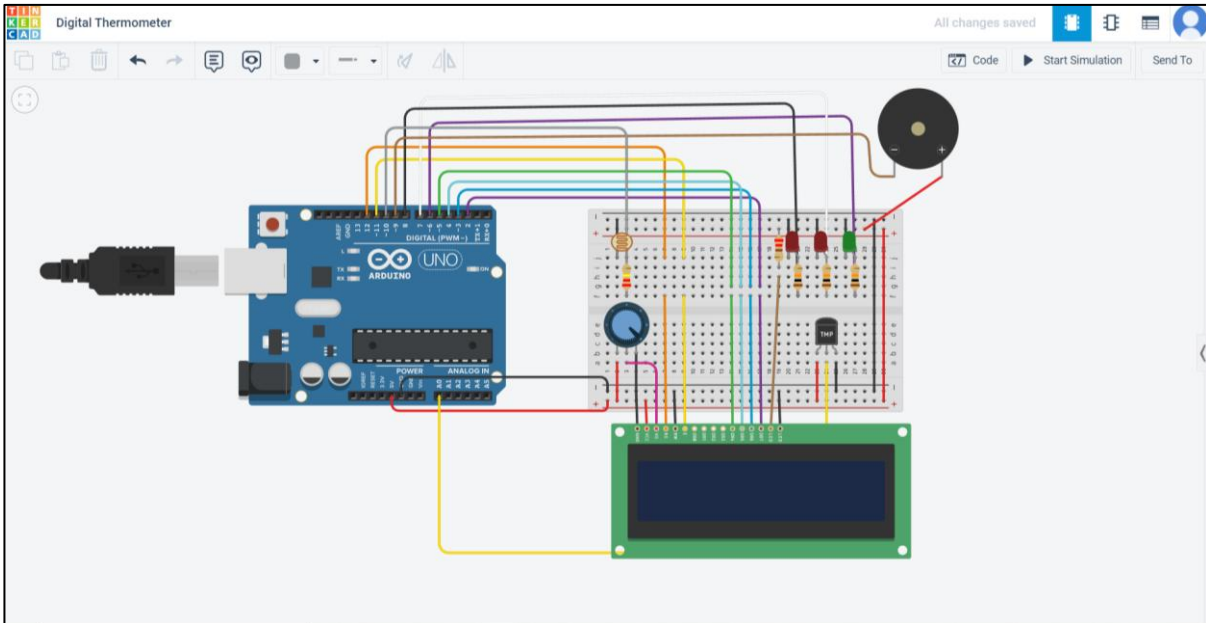

Commentary

The candidate has produced a detailed and functional virtual model, demonstrating thorough knowledge of a range of virtual modelling tools, including simple drawing, simulation and use of virtual instruments.

It shows how the overall system, as well as all subsystem blocks, work to achieve all of the required outcomes. The virtual model meets all of the requirements of the design criteria in the brief.

All the required changes and modifications that are required as a result of the model are listed.

All the wires have been well routed and appropriately colour-coded. The model is programmed so the potentiometer can be moved to replicate the light/lumens. The temperature sensor takes real-world temperatures, and this is displayed on the LCD monitor. The coding is appropriate and is functional in the virtual setting.

1d) Bill of materials

Candidate evidence

Equipment	Quantity/details	Justification
<p>Hand tools and equipment</p> <p>Hand tools to include:</p> <ul style="list-style-type: none"> • Wire cutters • Pliers • Screwdrivers (various) • Crimping tool • Level • Tape measure • Metre ruler and pencil for marking <p>Equipment to include:</p> <ul style="list-style-type: none"> • Power drill • Calibrated test equipment (multimeter, voltage indicator, proving unit) • Cable identification markers 	1 of each type of tool	<p>All hand tools selected to aid with the installation of the prototype. Hand tools including the wire cutters, pliers, crimping tool and screwdrivers will allow for wiring of the control panel to be completed efficiently.</p> <p>The level, tape measure and metre ruler will aid with marking up the where the panel is to be installed and ensuring that the panel is level.</p> <p>The test equipment will be used to ensure that connections are sound, as well as used for performing any isolations that may be required and checking for dead.</p> <p>All tools and equipment to be in good working condition as per PUWER regulations, and electrical test equipment to be calibrated and checked for electrical safety under the GS38 guidance.</p>
Light sensor LXT - TRM	1	Help with the set-up and installation of the light sensor.
Temperature sensor TES PT1000	1	Help with the set up and installation of the temperature sensor.
Power supply/power source	24VDC power source	Provide power to the system so the prototype can be function checked.

LED control panel indicator lights	9	<p>9 lights chosen as per specification.</p> <p>1x power on.</p> <p>1x Nearing operating limit lower range lighting.</p> <p>1x Reached operating limit lower range lighting.</p> <p>1x Nearing operating limits higher range lighting.</p> <p>1x Reached operating limits higher range lighting.</p> <p>1x Nearing operating limit lower range temperature.</p> <p>1x Reached operating limit lower range temperature.</p> <p>1x Nearing operating limits higher range temperature.</p> <p>1x Reached operating limits higher range temperature.</p>
Alarm sounders (Piezo alarm)	4	<p>4 audio alarms to sound.</p> <p>1x low end operating limit reached lighting.</p> <p>1x high end operating limit reached lighting.</p> <p>1x low end operating limit reached temperature.</p> <p>1x high end operating limit reached temperature.</p>
Wire 1.5mm Black and Red	4m of each	<p>Black wire for the negative wiring.</p> <p>Red wire for the positive wiring.</p>
PID controller	1	<p>Proportional, integral and derivative controller to allow reduction of overshooting and increase system stability.</p>
VDU interface YC – 15 EBT 15.6inch.	1	<p>Appropriately sized VDU as will allow operator or user to clearly see the measurements of the lighting and the temperature.</p>

Technical documentation (Manufacturers' manuals for the sensors and the VDU, sketches produced, risk assessment, design specification and diagrams)	1 copy of each document.	Manual to ensure the sensors are set up as per the manufacturer's recommendations and specifications. Manual for the VDU so it can be set up correctly. Risk assessment required under the HASAWA 74. Design specification and diagrams to be followed throughout to ensure that all steps are completed correctly.
Fastenings and fixings	Wall plugs and screws.	To ensure the control panel and the controller is securely fixed to the wall.
Panel	1 panel which will hold the alarms and the VDU	To seat the components and wiring.
Wire for VDU	1m of HDMI wire	To connect the VDU to the system.

Commentary

The candidate has presented a detailed and extensive bill of materials, having considered the different aspects of the design, laying the materials list out neatly and clearly in a table.

The bill of materials shows details and quantities of all tools, equipment and consumables required to complete the installation of the design, for example the amount, size and type of wires required, the sensor types as well as the alarm types. There is also detailed justification on the reasoning of each piece of material or equipment listed, explaining how and why it will be used.

The individual components and consumables are specified and are reflective of the design specification. The candidate has demonstrated that they have shown consideration for whole design and the complete process.

Although the model numbers of the sensors are stated, the candidate could have developed the response even further by detailing the model of the PID controller chosen for the design.

Task 2 – Manufacture and test

(Assessment themes: Health and safety, Manufacturing, Reports)

For task 2, candidates need to produce the following pieces of evidence :

- a) Risk assessment
- b) Prototype
- c) Test and verification records.

- Assessor observation of:
 - Construction of prototype
 - Testing and verification

Photographic evidence which shows:

- Sequence of photos during the construction of the prototype to include:
 - Results of tool selection and usage (photographs 1 & 2)
 - Wiring – dressing of cables (photograph 3)
 - Control hardware (photograph 4)
 - Interfaces (photograph 5)
 - Sub-assemblies (photograph 6)
 - Final prototype (photograph 7)

Video evidence which shows:

- Functionality of the prototype

2a) Risk assessment

Candidate evidence

Hazard	Risk	Control measures	Likelihood	Severity
Working area at all stages of the design, developmental, testing and completion of the control system prototype	Slips, trips and falls.	Ensure area is clean and tidy before beginning the build, during the activity and upon completion. Ensure control measures are in place such as spill kits for any leaking liquid.	2	2
Use of machinery for the development of the prototype of the control system	Entrapment.	Ensure processes are shut down before modifying systems, following the correct isolation procedures. Ensure safety guards and mechanisms are fully functioning before activating or working on any piece of machinery.	3	3
Working live in a system that uses stored energy / temperature through the development stages of the prototype	Burns, scalds.	Follow correct procedures when working on the powered-on system. Allow sensors to cool down before handling.	3	2
Use of hand tools and equipment in the development and testing of the components within the prototype control system	Cuts, abrasions, general hand injury.	Ensure appropriate selection of hand tools for the specific task. Inspect tools and equipment before use to ensure they function correctly. Ensure that the user has completed adequate/required training before being allowed to use tools and equipment. Follow guidelines for PUWER (provision and use of work equipment regulations). Wear correct PPE at all times, depending on the tools and equipment used. Wear gloves when working with hot components and safety glasses to protect from flying debris e.g. when snipping wires.	2	2
Use of live electricity to test the functionality of the designed prototype and its circuitry	Electrocution.	Safe isolation, LOTO and testing for dead, safe release of stored energy. All isolation steps and procedures will be in compliance with the BS7671 wiring regulations.	3	4

Equipment malfunction / faulty components	Issues with system whilst modifying / installing new equipment.	Safe isolation, LOTO and testing for dead. All isolation steps and procedures will be in compliance with the BS7671 wiring regulations. Ensure safety guards and mechanisms are in place and fully functioning in case of any equipment malfunctions.	2	2
---	---	--	---	---

Likelihood		Severity	
1	Very unlikely to happen	1	Minor injury
2	Unlikely to happen	2	Major injury
3	Possible to happen	3	Loss of limb
4	Likely to happen	4	Death of an individual
5	Very likely to happen	5	Multiple deaths

Commentary

The candidate has produced a detailed and clear risk assessment that identifies the main hazards and their associated risks and recommends a variety of appropriate control measures for each hazard and risk. They have fully considered the likelihood and severity of injury caused by each hazard, and they have also provided a chart to explain the likelihood and severity scores.

The hazards listed apply to this specific task of producing the prototype and include reference to handling stored energy, flying debris from cutting wires as well as specific PUWER requirements for using power tools and equipment safely.

The control measures suggested are detailed and appropriate and include reference to specific legislation relevant to the activity, as well as training requirements and inspection of tools, equipment and machinery prior to commencing any work.

2b) Manufacture of the prototype

Photographic/video evidence

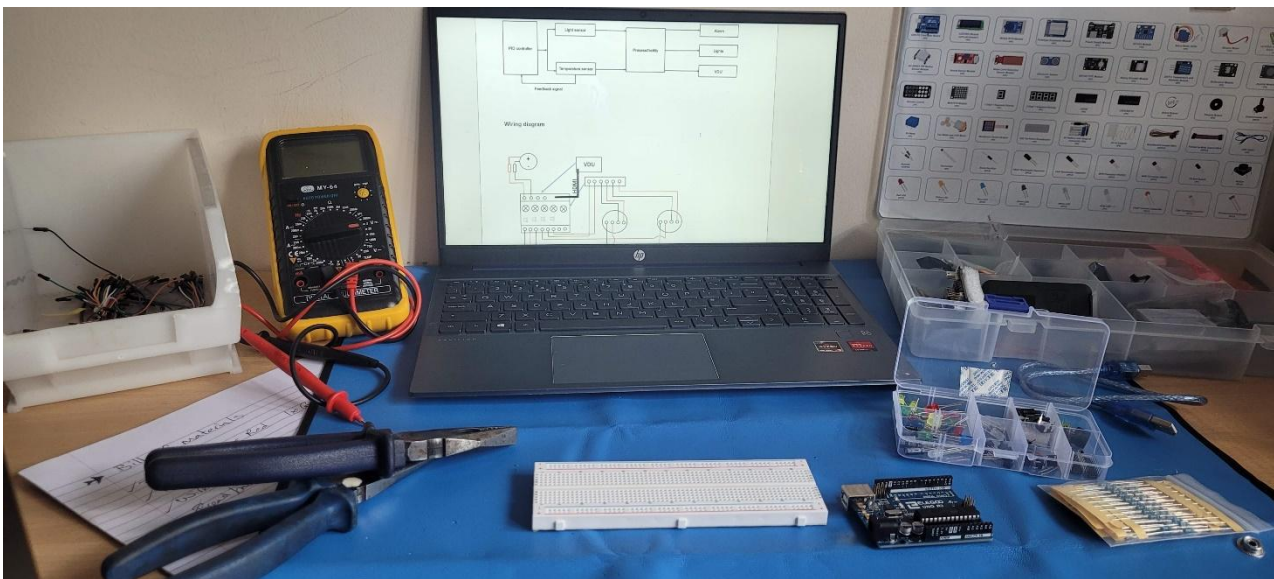

Photographs 1 & 2 show the prepared work area, with a clear and logical sequencing of tools and equipment on an ESD mat, technical documentation positioned to hand, but not interfering with the workstation. The use of organisational boxes for effective assembly and tidy working area. This is set in an electronics lab where the Health and Safety signage is already in place and appropriate.

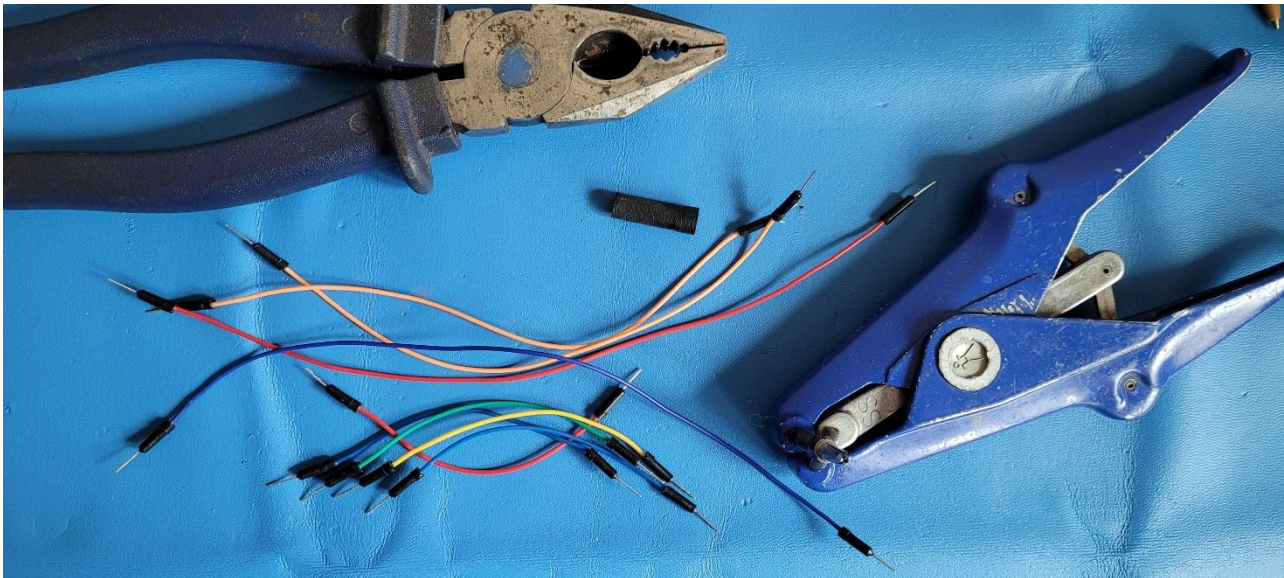

Photograph 3 shows the dressing of cables. The dressing is undertaken with a high degree of accuracy and using appropriate tooling. The finished wires show an excellent quality finish with no exposed wires evident.

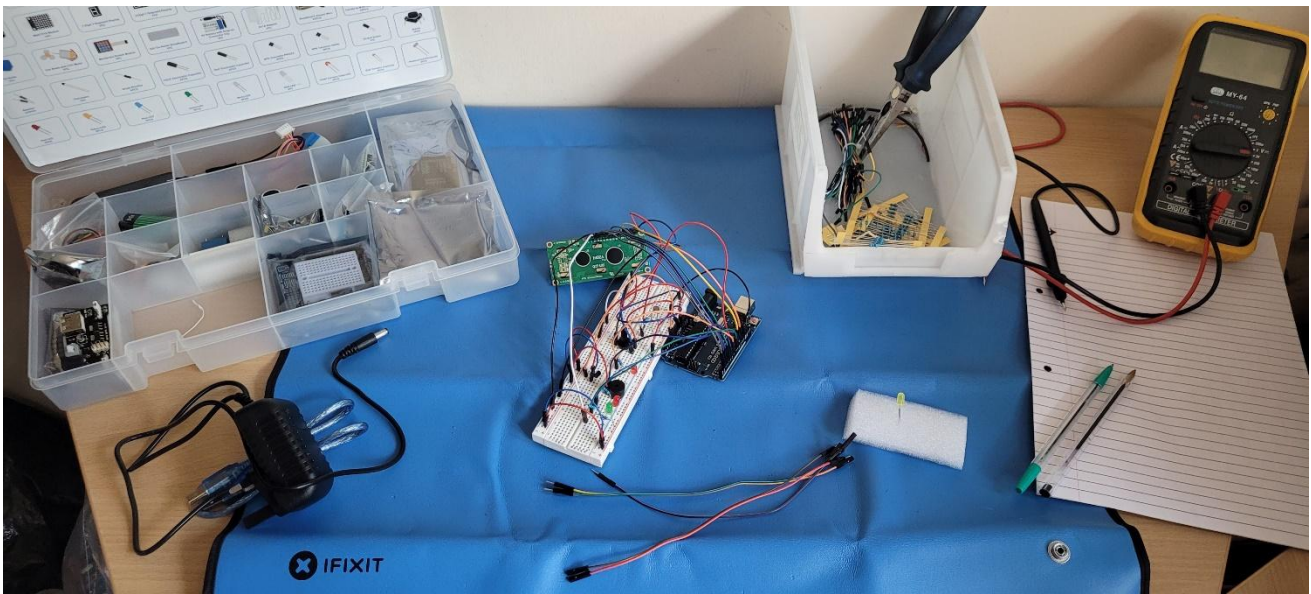

Photograph 4 shows the development of the control hardware. Detailed assembly and methodical working are evident, components are positioned on the breadboard in a logical order with appropriate wire colours. For example, black wire for negative and red wire for positive is consistent throughout the assembly/components.

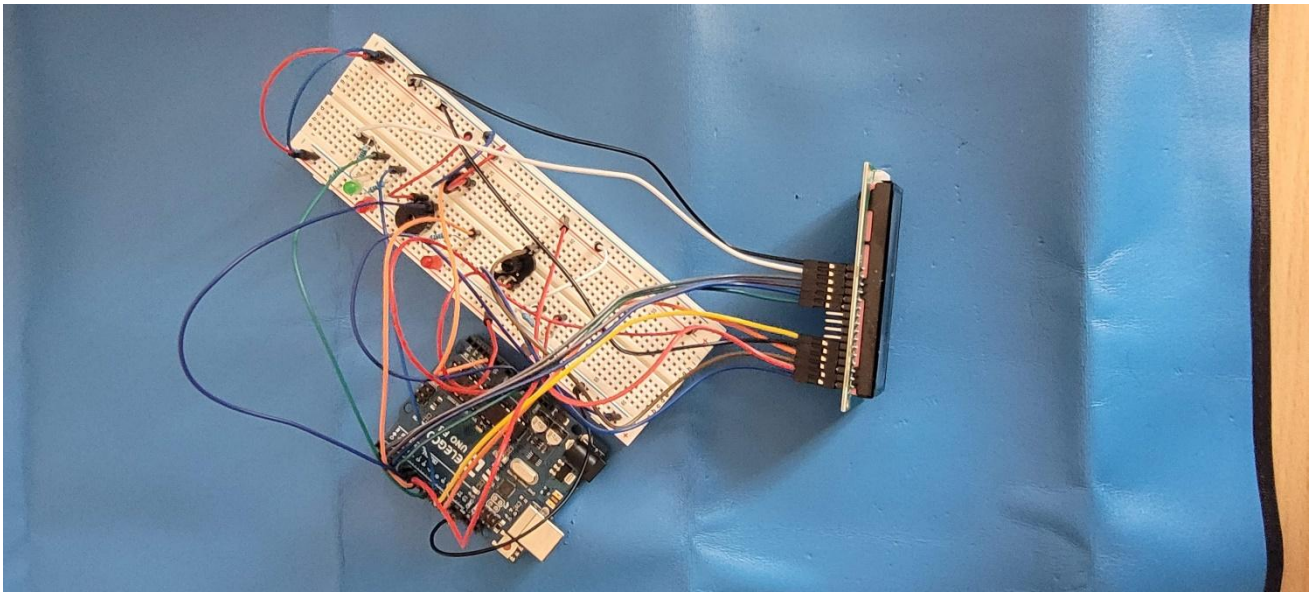

Photograph 5 shows the interfaces using an Arduino uno, breadboard and LCD demonstrating a careful and detailed production and assembly. All wiring to the LCD is accurate, locating the appropriate wire to corresponding connection point.



Photograph 6 shows the positioning of the sub-assemblies. Ordering is accurate and functional. The Arduino coding program is running and the correct connections/interface to the laptop have been used. The coding is accurate for correct operation of the system. The system is laid out to prevent accidental dislodging of wires or components.

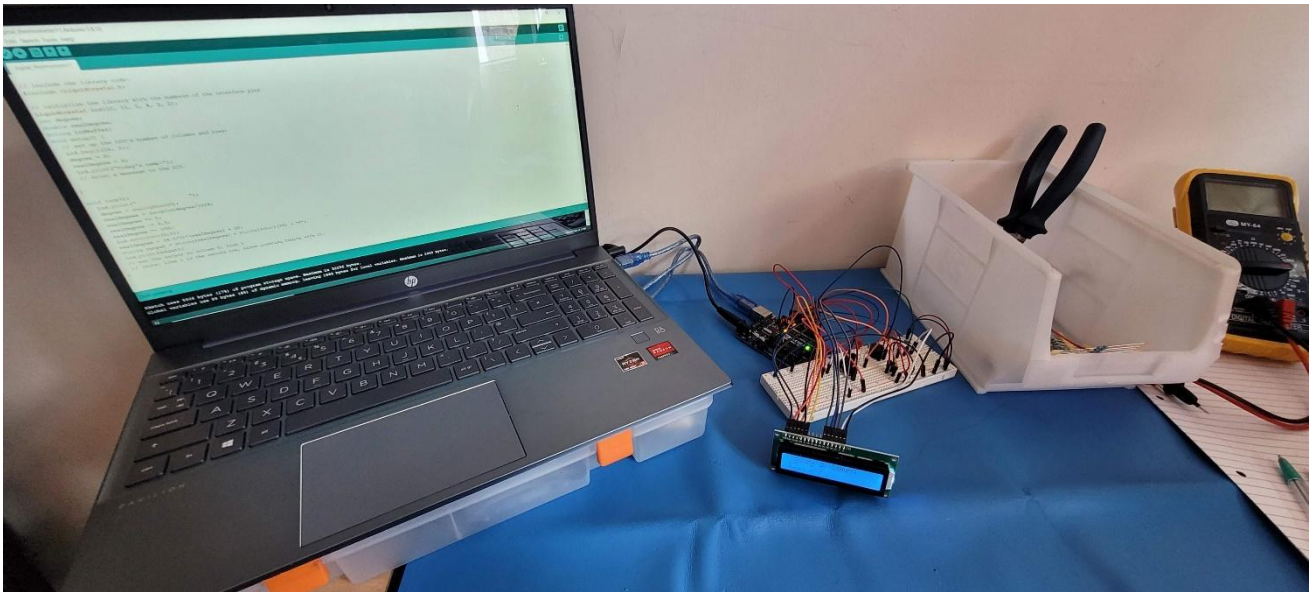

Photograph 7 shows the finished prototype. The prototype shows a quality and accurate finish and operation (using Arduino programming). The display on the LCD is currently showing the temperature and lights flash to indicate tolerances have been met with a buzzer to sound when operation limits are reached.

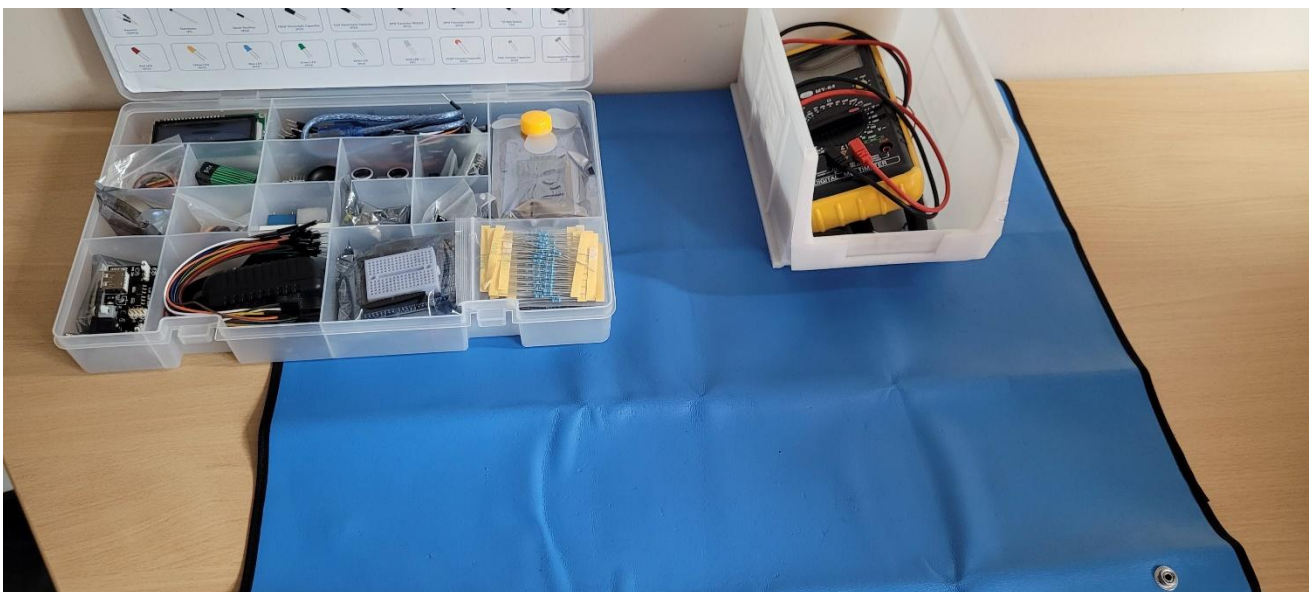

Photograph 8 shows that the candidate has returned all of the tools and resources to the toolbox. This has been left tidy and ready for its next use.

Video showing the functionality of the prototype:



CI D video 1.mp4

Practical observation form – Prototype

Assessment ID	Qualification number
8714-323	8714-33
Candidate name	Candidate number
Candidate A	CG12345
Centre name	Assessment theme
City & Guilds	Health and Safety Manufacturing

Complete the table below referring to the relevant marking grid, found in the assessment pack. **Do not** allocate marks at this stage.

Task	Notes – <i>detailed, accurate and differentiating notes which identify areas of strength and weakness are necessary to distinguish between different qualities of performance and to facilitate accurate allocation of marks once all evidence has been submitted.</i>
Prototype	<p>The candidate used their bill of materials to gather the required tools, equipment and PPE needed for the task. The tools, equipment and systems selected were correct for the task in-hand. Each resource was placed at the workstation in a logical order for intended use. The candidate carefully inspected each piece of equipment to ensure it was in a safe working condition and confirmed the calibration date of each piece. The candidate reviewed the work environment and showed consideration of controls in their risk assessment. This included moving an object in the hallway to a secure place and advising others working nearby that they would be undertaking practical work.</p> <p>The candidate ensured a range of technical information and manufacturer’s datasheets was available to them prior to starting the task. This included their initial design documentation, as well as their risk assessment. These documents were carefully placed within easy reach of the workstation, but out of the way of interfering with any of the task. The candidate rechecked the risk assessment and did further checks of the work area before commencing work on the prototype.</p> <p>The candidate undertook the construction of the prototype, ensuring that they referred regularly to their initial design specification and diagrams. The prototype was assembled correctly with all steps followed concisely.</p> <p>The candidate demonstrated a range of skills, including the interpretation of the requirements, correct use and application of the documentation and good hand skills including correct use of tools and equipment throughout the construction of the prototype. The individual components were carefully and appropriately handled using the correct tools. For instance, the wiring of the light and temperature sensors showed a high degree of skill, and this was affirmed through an excellent finish that showed consideration for quality and accuracy, with no exposed wires and with all connections checked and secured correctly.</p>

Task	Notes – <i>detailed, accurate and differentiating notes which identify areas of strength and weakness are necessary to distinguish between different qualities of performance and to facilitate accurate allocation of marks once all evidence has been submitted.</i>
	<p>The candidate demonstrated a high degree of accuracy when measuring consumables. Wires were measured and cut with precision, and this allowed the components to be assembled correctly without any rework required.</p> <p>The control system was assembled following the design specification. The assembly was accurate, with individual sub-assemblies and system blocks considered and positioned correctly and with precision. The candidate checked each stage of the assembly to confirm that the intended requirement was met, before moving to the next stage. At all times the candidate ensured a high level of finish when working with materials, for instance tightening and re-tightening all screw connections to ensure that they were fastened securely.</p> <p>The candidate made some coherent checks of the final assembled prototype, comparing the output to what had been initially intended. The candidate secured and cleaned the work area and reset ready for testing. On observing the finished prototype, this was found to be appropriately compiled, with a clear and clean finish to all elements.</p> <p>The candidate was conscientious at all times with regard to health and safety of themselves and those around them. Tools and equipment were placed carefully out of the way after use, and the candidate ensured that used consumables and off-cuts were removed and disposed of carefully following correct workplace regulations. The candidate checked tools again before re-use, using a range of senses to ensure that the tool was still functioning correctly. Prior to moving to the testing element, the candidate reset the work area – cleaning down and returning equipment. Equipment was checked prior to return.</p>

Assessor signature	Date
Assessor A	03/04/2022

Commentary

The candidate was observed undertaking the correct and accurate construction of the prototype. The candidate demonstrated a high degree of skill to effectively complete a finished prototype, that fully reflected the initial design intentions. The candidate performed the construction of the prototype with a high regard for health and safety. A range of pre-work checks were undertaken, that were followed by consistent consideration of health and safety throughout the construction of the prototype.

The candidate developed the prototype following a clear, logical and defined sequence. Work was checked after each stage to confirm accuracy and quality of finish, before moving to the next element of the task. This ensured the construction was effective and accurate, and meant that no rework or revisions were required throughout the construction.

The candidate demonstrated excellent use of hand skills when using tools and equipment, that was appropriately reflected in the finish of the prototype that was noted to be clear and clean, without any compromises in final quality.

2c) Testing and verification

Test record

Test requirement	Pass/Fail	Comments
The system powers on	Pass	The system is in receipt of power, as expected. The 'power' button is illuminated, and the VDU and controller are switched on which indicates they have power to them.
The lights illuminate at the required points	Pass	It was visually identified that the correct lights illuminated at the correct times. When the temperature level was reduced the nearing operational light illuminated for the temperature and the lighting element of the process. Once the operating limit had been reached the required bulbs illuminated for both the temperature and the lighting element of the process.
The system is stable and capable of automatically regulating a temperature within a range of 18°C – 24°C	Pass	When the temperature fluctuated and approached the limits of the accepted parameters, the system regulated the temperature to within the acceptable range of 18°C – 24°C. The automated regulation of the system will be done through the PID controller. The PID controller uses the proportional, integral and derivative control to adjust the system automatically. The PID controller calculates and compensates for changes in the values.
The temperature control system does not exceed three overshoots on first switching on from a 30°C start	Pass	This was tested three times by switching on, and in all cases the control system did not go over three overshoots.
A pre alarm sounds when the temperature is nearing the range limits	Pass	The pre alarm indicators illuminated at 19°C and 23°C and the audio alarms sounded at 18°C and 24°C to indicate the limits had been reached.
The system provides a visual output showing the temperature and light level measurements in real time	Pass	The VDU shows the temperature and light level measurements at the time. When these were out of the required parameters due to the testing, a red flashing sign was displayed.
The system records parameters relevant to its operation	Pass	The system has no capability of saving and storing the parameters and readings, however these can be obtained manually by recording the results displayed on the VDU and logged down in paper form.
The system changes the desired temperature range	Pass	The controller allows the user to select a different temperature range from a pre-determined set of ranges.

and light level to suit different produce		
The system detects when the light level, above the produce, is below 10,000 lux	Pass	Tested at light levels of 10,100 lux where there was no warning. Tested again at 9,700 lux above the produce and the drop was detected and flagged.

Practical observation form – Testing of the prototype

Assessment ID	Qualification number
8714-323	8714-33
Candidate name	Candidate number
Candidate A	CG12345
Centre name	Assessment theme
City & Guilds	Health and Safety Manufacturing

Complete the table below referring to the relevant marking grid, found in the assessment pack. **Do not** allocate marks at this stage.

Task	Notes – <i>detailed, accurate and differentiating notes which identify areas of strength and weakness are necessary to distinguish between different qualities of performance and to facilitate accurate allocation of marks once all evidence has been submitted.</i>
Testing of the prototype	<p>Following the development of the prototype, the candidate set the work area up in order to carry out testing. The candidate visually checked the work area to confirm that it was ready for testing. The risk assessment was revisited, and controls re-checked to confirm testing could be undertaken safely.</p> <p>The candidate ensured that they had access to the original design criteria and confirmed the requirements of the prototype prior to starting testing procedures. The test record they created lists all of the criteria in the brief in order to ensure that each criterion is tested separately.</p> <p>The candidate undertook a range of functional tests. The candidate checked that the temperature sensors would sound an alarm when the prototype was subject to temperatures out of the indicated range. The candidate checked that a pre-alarm sounded at below the minimum indicated temperature of 18°C, as well as above the maximum indicated temperature of 24°C.</p> <p>The candidate visually checked that the system could record different parameters relevant to its operation. The candidate was observed checking that the prototype visually displayed a current temperature and light level measurement. They also repeatedly switched on the system in order to test that it does not exceed three overshoots upon switching on.</p> <p>The candidate tested the light sensors by checking when the light level was manually dropped to below 10,000 lux by setting the light level at 9,700 lux and the system correctly flagged the dropped light level. They also tested at an acceptable light level of 10,100 lux.</p> <p>The tests were undertaken using a range of tools and electrical equipment and sensors. The candidate operated all the testing equipment safely and comfortably, noting the results of the test. The results were checked for accuracy, reviewed against the original design criteria and noted on the test record.</p>

Task	Notes – <i>detailed, accurate and differentiating notes which identify areas of strength and weakness are necessary to distinguish between different qualities of performance and to facilitate accurate allocation of marks once all evidence has been submitted.</i>
	When the testing had been completed, the candidate returned equipment correctly to its location in the workspace. A final check of the work area was made to ensure that it was ready for work by others.

Assessor signature	Date
Assessor A	03/04/2022

Commentary

The candidate successfully undertook a range of accurate testing procedures using appropriate tools, testing equipment and various sensors. The testing was undertaken accurately and following clear, logical process steps that follow the order of the design criteria. The candidate has stated whether the test was passed, indicating that all testing steps were successful.

The candidate has described the parameters of each test, for example by including the temperature values at which the alarm ranges were tested and the lux levels at which the light sensors were tested. The candidate explored a range of appropriate parameters. For example, checking that pre-alarm light indicators at 19°C and 23°C were illuminated, as well as checking that the minimum and maximum threshold temperatures of 18°C and 24°C respectively triggered an alarm sound.

The candidate ensured the integrity of the test by checking the readiness and calibration of testing equipment prior to starting each test, ensuring the reliability of the result. They sometimes tested the operation multiple times, such as in the case of the temperature controls on first switching on.

The test results were recorded accurately, interpreting the results against each of the original design criteria.

The candidate worked safely throughout the testing process, by inspecting the work area at the beginning of the process and also revisiting the risk assessment and re-checking the control. The candidate was also observed to be using the testing equipment safely.

Task 3 – Peer review

(Assessment themes: Reports)

For task 3, candidates need to produce the following pieces of evidence:

- Candidate notes on the candidate feedback record form

The candidate notes are not included in this document as the notes will vary from candidate to candidate and are not used to inform any other task.

- peer review feedback form.

This is supporting evidence for assessors to see what feedback the candidate received and how they used it in their review for task 4 and will not be marked.

Peer review feedback form

Candidate evidence

Candidate name	Candidate number
Candidate B	CG01234
Centre name	Centre number
City & Guilds	12345

Question	Feedback
How well does the design meet the requirements in the brief?	<p><i>The design meets the requirements of automatic regulation and monitoring of the lighting and temperature ranges. The design uses visual alarms to indicate when the temperature is nearing the limits and audio alarms to indicate when the range has been reached. The design is detailed and comprehensive and I feel all aspects of the design have been considered.</i></p> <p><i>The candidate has included pictures of the sensors which is a good way to show people what the sensors look like when evaluating the design and how well it will fit in the working environment.</i></p>
How appropriate is the equipment proposed for the design?	<p><i>The selection of the sensors is appropriate to the required ranges specified in the brief. The PID controller allows for the process to be automatically controlled. Implementing a VDU is an efficient way of obtaining parameters, readings and measurements in real time. All of the equipment to be implemented into the new design is appropriate.</i></p> <p><i>I understand why a potentiometer was used in the initial design, however in reality a PIR sensor would be more appropriate.</i></p>
What are the implications to the business of the proposed maintenance schedule?	<p><i>The system optimises the performance of the facility and in turn will save on money and time. However, the design will initially be expensive to purchase and set up, but quality of the process and product will be improved, so will counterbalance the initial costs eventually.</i></p>
How can the design be optimised/ improved?	<p><i>Introducing a remote monitoring system such as IRIS would enable the process to be monitored via a device. This would allow the state of the panel to be observed and controlled remotely. The candidate has briefly discussed the introduction of remote monitoring system however, the design would overall be improved if this was focused on more.</i></p>

Task 4 – Evaluation and implementation

(Assessment themes: Health and safety, Design and planning, Reports)

For task 4, candidates need to produce the following pieces of evidence:

- a) Outcomes of virtual modelling
- b) Revision control document
- c) Evaluation and implementation report.

4a) Outcomes of virtual modelling

Candidate evidence

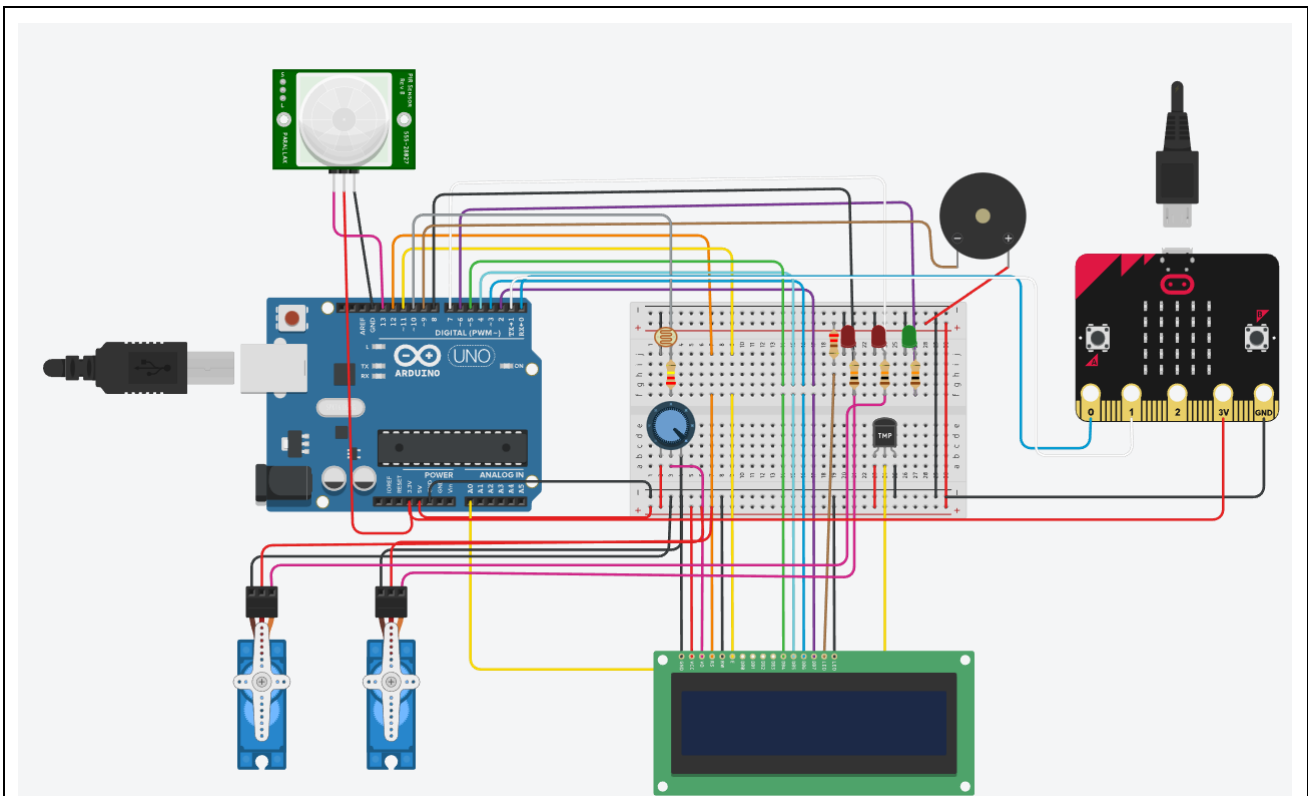

This now has two micro-servos to act as light and temperature units. A module has been added for Wi-Fi (remote monitoring) and a PIR (passive infrared) sensor.

This will make the system more efficient and sufficient for the user to monitor the system remotely with supporting software (app or hand-held computer).

Commentary

The candidate has added the required components as per the peer review and provided a description as the virtual modelling system will only allow a limited number/type of components.

The wiring is neat and of very good quality, with coding that suits the operation of the system. This now provides time, date, temperature and lumens to be displayed on the LCD. A Wi-Fi module has also been added for remote monitoring and this can then be adjusted through supporting software.

4b) Revision control document

System type	Temperature and lighting control system
System TAG number	XXXXXX
Department responsible for equipment	Design and Development department
System designed by:	Candidate A

Design description:

The process has been designed around the specification and requirements that were provided at the beginning of the task. Overall, the system allows for the monitoring of the lighting levels and the temperature levels of the process that is producing the batch product. The system is automatic and has the capability of displaying the real time readings of the process through a visual display unit that will be in situ within the control panel.

As well as the control panel seating the VDU, the control panel will include visual and audio alarms to indicate when each variable is nearing and has reached the operating limits set via the controller. The VDU chosen for the system is a YC – 15 EBT 15.6inch. This allows for easy viewing of the displayed measurements.

The system uses an LXT-TRM lighting sensor and TES PT1000 temperature sensor, which is connected to the PID controller. The PID controller was chosen as this uses derivative control which reduces the likelihood of overshooting as the signals are sent a lot faster.

The system will be powered from a 24vDC power supply.

Changes to existing system:

The process/system will now consist of extra sensor and module which will be fixed to the process.

There are currently no changes to the existing heating and cooling system that is installed. There was not enough information provided on the existing system so it was decided that the new process would be installed separately. In the future the two systems may be integrated. Both systems could be integrated into one control panel to reduce the amount of maintenance required.

The system does allow for any future changes or requirements of the batch process. The peer review feedback details a very valid recommendation of IRIS or similar remote monitoring system. This is something that will be considered for future changes to the process, once the system has been proved to be efficient, cost effective and accurate. At this stage, updating the system would incur extra costs, however the system can easily accommodate a remote monitoring system in the future.

Changes to existing technical documentation:

Maintenance manuals for the following components will need to be kept in house so engineers and operators can easily obtain them, and copies can be provided with the maintenance schedules:

- Visual Display Unit - YC – 15 EBT 15.6inch
- Temperature sensor - TES PT1000
- Lighting sensor - LXT-TRM
- PID controller - Novus N1200-24V

The current maintenance schedule and maintenance instruction will need to be altered as the new design will be on the same maintenance schedule as the pre-existing cooling and heating system as the run time and the importance of each system will be the same, therefore the maintenance steps and instruction can be merged and be maintained as an overall system.

The Risk Assessment requires updating to include the new equipment that has been installed so therefore posing more hazards than before.

Factors to be put into the risk assessment include:

- Overhead equipment i.e. sensors and cabling
- More electrical panels.

Equipment layout drawings will need to be modified to reflect the new installation.

Comments:

New drawings and diagrams will also need to be produced, checked and published including wiring diagram and schematic.

All the suggestions and changes to current documentation will need to be approved and completed prior to the final installation of the system. Once all of the new documents are developed and the changes to existing documentation have been completed, they will need to be reviewed and authorised.

Once all of these steps are completed, the final installation can commence.

Validation performed by:

Assessor 1

Prototype approved by:

Assessor 1

Date:

16/06/2022

Commentary

The candidate has provided a detailed description of the design, inclusive of the types of components and sensors that have been chosen, using some technical information to describe how the components selected will integrate. The candidate has listed the sensors, visual display unit and the PID controller inclusive of the make and model of each.

The candidate has provided an overall description of the design and explained how the design will meet the specifications and requirements. For example, providing an explanation of how the PID controller will help to reduce overshooting in the system.

The candidate has clearly identified the changes to the system, explaining that the sensors will be fixed to the process. The candidate has clearly identified that there are no changes to the pre-existing cooling and heating system with a justification of why this is the case. The candidate has also discussed the peer review feedback and how this has been considered, for example explaining the system could be adapted to meet the recommendation in the future.

The candidate has clearly considered the system use and maintenance requirements which is demonstrated through the consideration of ensuring the manufacturer's manuals are available for not only the installation but future maintenance too. The candidate has provided a list of brands and model types of each component which allows for them to be easily found.

The candidate has demonstrated efficiency through the recommending of the current system and the new design to be integrated with regards to maintenance. The candidate has demonstrated forward thinking and considered that both systems will be running for the same amount of time, therefore will require the same maintenance schedule and maintenance requirements. The candidate has considered the changes to the environment because of the new system, demonstrating good awareness and knowledge for the risk assessment process by requesting that this needs to be updated.

4c) Evaluation and implementation report

Candidate evidence

Implementation	<p>Now that the prototype has been proven and all documents are revised, the implementation of the design can begin.</p> <p>A meeting will need to be held to identify who will be involved with the installation and commissioning of the system.</p> <p>The tasks that need to be completed to successfully implement the design include:</p> <ul style="list-style-type: none">- Planning and preparation, including planning meeting- Obtain the documentation required, including the wiring diagrams, equipment layout diagrams and risk assessment.- Obtain all tools and equipment including checking the condition and calibration.- Obtaining the components and equipment to be installed and performing overall checks- Check all the materials against the bill of materials to ensure everything has been selected and the correct types are selected.- Mark up the location of the panel, controller, and the location of the sensors on the system.- Carry out the fixing of the panel, controller, and the sensors. Use measurement equipment to ensure that the installation is level and positioned correctly.- Fix the VDU and components into the panel, before proceeding to wire up the components. Components to be installed into the panel are the 9X LED's, 4X alarms, PID controller and VDU. All the wiring will be completed as per the BS7671 Wiring Regulations. The power requirements for the system are 24vDC. The wire used will be 1.5mm wire and will be wired as per the wiring diagram. The VDU will be connected through HDMI cable.- All terminations to be crimped with the appropriately sized ferrules and cable identification markers will be attached.- The sensors to be fixed to the process and wired back to the controller.- Visual and movement inspections to be completed before the commissioning stage.- Continuity test to be conducted to ensure that all connections are electrically sound. <p>The system will be commissioned as follows:</p> <ul style="list-style-type: none">• Power to the system – It is important that this step is completed only once the installation is complete and has been inspected and tested.• Visual and sensory checks for any obvious signs of issues once power has been applied. Sensory checks include listening for any out of the ordinary sounds or buzzing, smelling for any apparent electrical burning and visual inspections for any signs of electrical damage such as melting insulation.• Complete checks on the components within the panel, i.e the bulbs and the piezo alarms ensuring they illuminate and sound when required.
-----------------------	--

	<ul style="list-style-type: none"> • Ensure power to the sensors and the sensors are feeding back to the controller. • Ensure correct operating limits are set through the controller. • Complete a period of observation before varying the temperature and light levels, recording, and noting the response at the control panel to ensure working within specification. • Ensure the VDU is lit up and displaying the correct levels of temperature and light. <p>Health and Safety Regulations to be adhered to include:</p> <p>Electricity at Work act 1974</p> <p>Health and Safety at Work Act 1974</p> <p>The Workplace Regulations 1992</p> <p>Personal Protective Equipment Regulations 2002</p> <p>Provision and Use of Work Equipment Regulations 1998</p> <p>Upon completion it is important that all checks and results are recorded and stored for future reference. Any changes or issues must be identified and reported as well as any recommendations or alterations that were made.</p> <p>The installation and commissioning process should take 2 days maximum. All parts ordered will be used, where further stock is required, this can be recorded in a job completion report to manage stock and resources.</p>
<p>Evaluation</p>	<p>Overall, the implementation process is complete and proves the system to be operating as requested.</p> <p>Upon evaluating the preparation stage of the design, it was noted that the Bill of Materials could have included more details. The Bill of Materials did not include the connecting of the VDU, which would have required a HDMI adapter and cable to be integrated.</p> <p>During the testing of the prototype, it was confirmed that the system powered on as there was power to the controller, sensors and the power indicator illuminated, proving that the correct supply voltage, 24vDC, was selected and is appropriate for the process.</p> <p>The system proved to meet the specifications of the design through confirming that the control panel indicated when the setpoints were met. The inputted temperature and lighting levels triggered the expected response through the controller and control panel.</p> <p>The pre-alarms illuminated at 19°C and 23°C.</p> <p>The audio alarms sounded at 18°C and 24°C.</p> <p>This confirms that all the equipment and components selected are appropriate and meet the requirements of the overall task. During the testing performance, it was noted that the alarms should sound at the pre-alarm levels. This would improve the system for the operators as they may not always be looking at the panel.</p> <p>As suggested in the peer review, a remote monitoring system would further improve the efficiency of the system. This would allow for the system to be monitored in the control room so if the process was not manned, the system could still be viewed and issues such as the pre-alarm lighting and temperature levels being reached could be addressed sooner.</p>

	<p>The location of the panel is easily accessible and the implementation of a 15.6-inch display will allow for the readings to be visual to the operators working at the process. The sensors are appropriately located as they are positioned over the top of the process and are consistently taking readings of the temperature and level as they are fixed.</p> <p>To further improve the system overall, the existing heating and control system could be integrated to the new process. This could be achieved by wiring the new process to the existing process. This would provide automatic control of the heating and cooling elements. When the set points are nearing, the heating or cooling element would automatically respond and activate. This would allow for full automated control of the process. It is recommended that this be looked at as a future recommendation.</p> <p>The selected sensors, controller and VDU allow for different parameters and setpoints, therefore meaning the process can be adapted to different types of batch growing with different temperature and lighting requirements.</p> <p>Overall, the design meets the requirements of the brief. All evaluations submitted are for future consideration and at this stage there is no requirement to implement these. Upon confirmation of the new system running and proving successful, the improvements may be added at a later date.</p>
--	---

Commentary

The candidate's implementation and evaluation report is detailed and clear, identifying well, the approach to be taken to the implementation. The candidate has considered the planning and preparation factors that need to be considered before proceeding to install and commission.

The candidate has provided a detailed list of steps that will be completed as part of the implementation process setting them out in a logical order, demonstrating that the candidate has thought about all factors to be considered during installation. The candidate has listed and identified the components that need to be obtained and the amounts. The candidate has included technical detail and referenced clearly to the equipment and component types.

The candidate has demonstrated their awareness for regulatory requirements and available guidance by listing some of the regulations relevant to the implementation process, for example the BS7671 Wiring Regulations. The candidate has demonstrated safe working behaviours by identifying that the installation of the process should be thoroughly checked and inspected before supplying power to the system.

The candidate has demonstrated a good understanding for the evaluation process, providing detailed evaluations of specific parts of the whole process, identifying areas where improvements could be made, justifying how these would be beneficial to the system. For example, considering the remote monitoring system suggested in the peer review feedback and improving the system by wiring up the new design to the pre-existing heating and cooling system.

Copyright in this document belongs to, and is used under licence from the Department for Education, © 2023 - 2026.

'T-LEVELS' and 'T Level' are registered trade marks of the Department for Education.

© City & Guilds Limited is authorised by the Department for Education to develop and deliver this T Level Technical Qualification.

City & Guilds is a registered trade mark of © City & Guilds Limited.