



T Level Technical Qualification in Design and Development for Engineering and Manufacturing (8714-34)

Occupational Specialism in Structural Engineering

Guide Standard Exemplification Material Distinction

| Version and date | Change detail | Section |
|-------------------------|--|----------------|
| 1.1 January 2023 | Formatting of Task 1 evidence requirements | Task 1 |
| 1.2 February 2023 | Evidence requirements updated | Task 1(h) |
| 1.3 March 2026 | Minor amendment to first paragraph | Introduction |

Contents

| | |
|---|-----------|
| Introduction | 3 |
| Grade descriptors | 4 |
| Task 1 – Design | 5 |
| 1a) <i>Design specification</i> | 6 |
| 1b) <i>Annotated sketches</i> | 8 |
| 1c) <i>Justification of the choice of one design for further development.....</i> | 14 |
| 1d) <i>Justification of the selection of the materials and components</i> | 15 |
| 1e) <i>Calculations.....</i> | 16 |
| 1f) <i>Engineering drawings of the proposed design.....</i> | 19 |
| 1g) <i>Outcomes of the virtual modelling of the proposed design.....</i> | 21 |
| 1h) <i>Bill of materials.....</i> | 30 |
| <i>Notes of research undertaken.....</i> | 31 |
| Task 2 – Manufacture and test..... | 32 |
| 2a) <i>Risk assessment.....</i> | 33 |
| 2b) <i>Manufacture of the prototype</i> | 36 |
| 2c) <i>Testing.....</i> | 46 |
| Task 3 – Peer review | 52 |
| <i>Peer review feedback form</i> | 53 |
| Task 4 – Evaluation and implementation..... | 54 |
| 4a) <i>Outcomes of virtual modelling.....</i> | 55 |
| 4b) <i>Revision control document.....</i> | 58 |
| 4c) <i>Evaluation and implementation report</i> | 60 |

Introduction

The Guide Standard Exemplification Material within this document refer to the T Level Technical Qualification in Design and Development for Engineering and Manufacturing - Occupational Specialism in Structural Engineering sample assignment. The aim of these materials is to provide centres with examples of knowledge, skills and understanding that attest to distinction competence. In this document all exemplar evidence attests as examples of performance at the distinction grade boundary. The examples provided do not reflect all evidence from the sample assignment as the focus of this material is the quality and standards that need to be achieved rather than the volume of exemplar evidence provided. However, the examples provided are representative of all tasks in the sample assignment. The evidence presented here has been developed to reflect a distinction grade within each task but is not necessarily intended to reflect the work of a single candidate. It is important to note that in live assessments a candidate's performance is very likely to exhibit a spikey profile and the standard of performance will vary across tasks. A distinction grade will be based on a synoptic mark across all tasks.

The materials in this Guide Standard Exemplification Material (GSEM) are separated into three sections as described below. Materials are presented against a number of tasks from the assignment.

Task

This section details the tasks that the candidate has been asked to carry out, what needs to be submitted for marking and any additional evidence required including any photographic evidence. Also referenced in this section are the assessment themes the candidates will be marked against when completing the tasks within it. In addition, candidate evidence that has been included or not been included in this GSEM has been identified within this section.

In this GSEM there is candidate evidence from:

Task 1

Task 2

Task 3

Task 4

Candidate evidence

This section includes exemplars of candidate work, photographs of the work in production (or completed) and practical observation records of the assessment completed by centre assessors. This will be exemplar evidence that was captured as part of the assessment and then internally marked by the centre assessor.

Commentary

This section includes detailed comments to demonstrate how the candidate evidence attests to the standard of distinction competence by directly correlating to the grade descriptors for this occupational area. Centres can compare the evidence against the performance indicators in the marking grid descriptors within the assessor packs, to provide guidance on the standard of knowledge, skills and understanding that need to be met for distinction competence.

It is important to note that the commentary section is not part of the evidence or assessment but are evaluative statements on how and why that piece of evidence meets a particular standard.

Grade descriptors

To achieve a distinction, a candidate will typically be able to:

Demonstrate a comprehensive use of software/ technologies to model, evaluate and produce structural engineering diagrams and simulations that meets the requirements of the brief.

Demonstrate excellent technical skills when developing models and prototypes, resulting in a model that is fully functional.

Apply comprehensive knowledge and understanding of testing processes, resulting in a model that has been tested against all of the design criteria.

Critically interpret information to plan, assess risk, follow safe working practices and apply the technical skills to practical tasks and procedures to an exemplary standard in response to the requirements of the brief, producing an excellent quality of work.

Apply comprehensive knowledge and understanding of the design principles required for structural engineering resulting in proposals and solutions that meet all requirements of the brief.

Work safely and make well founded and informed decisions on the selection and appropriate use of tools, materials and equipment within the environments that they are working in, resulting in tasks that are carried out to a high degree of accuracy.

Use accurate industry and technical terminology consistently in both written and verbal contexts.

Task 1 – Design

(Assessment themes: Health and safety, Design and planning)

For task 1, candidates need to produce the following pieces of evidence:

- a) design specification
- b) up to three annotated sketches
- c) justification of the choice of one design for further development
- d) justification of the selection of the materials and components
- e) calculations, including all workings
- f) engineering drawings of the proposed design
- g) outcomes of the virtual modelling of the proposed design, either as screen captures or printouts
- h) bill of materials.

For Task 1, the following additional evidence may also be submitted:

- any notes produced of research undertaken including citation of sources and internet search history.

1a) Design specification

Candidate evidence

A new pylon design is required to be developed for an electrical company. The pylon is to be modern in style and to make a limited visual impact on both the urban and rural skyline. The colour and shape of the pylon will need to be carefully considered so that it blends into the horizon. Cesar Pelli one of the most famous skyscraper architects in the world recently covered a building in mirrors to help it merge with its surroundings. Mirrors for pylons might cause problems for birds and other wildlife, with the potential for the mast or arms of the pylon to be struck by fauna. Selecting a light colour that reflects the skyline is more sensible; light grey, light blue or white are suitable. The massing, visual and aesthetic impact of the pylon should be considered in the near, middle and far view. To reduce the visual impact the spacing between pylons can be carefully considered, as greater spacings will reduce the overall number of pylons required. Typically, pylons which carry electricity greater than 100 kilo volts are positioned at 150 m to 300 m (Quora, n.d).

Traditional pylons are manufactured from steel and are usually made from lattice sections. Pylons can be a number of different shapes but 'fir tree', 'barrel', Danube, 'Y' and 'H' types are typical across the world. In the UK, most pylons are of the 'L6' and 'L12' type and were introduced in the 1930s being designed at that time by the Milliken Brothers from America. Little has changed until recently when more modern designs are being introduced using circular hollow sections and more fluid organic shapes like the 'Terna' pylon (Terna, n.d.). To appear modern, it is recommended that the final design of the pylon avoids traditional lattice construction. At present in the UK there are approximately 90,000 pylons and if all of these are to be eventually replaced by the new pylon, then any design selected needs to be able to be manufactured in volume. Consequently, a simpler shape might be beneficial and ultimately more cost effective.

The pylon is to be sustainable and easily repurposed at the end of its life. To meet the requirements of best practice and design standards the pylon is to have a minimum design life of 50 years (European Standard, 1991). Different construction materials have different levels of embodied energy, which is the energy used in producing, transporting, installing, maintaining and disposing of a material. Aluminium has the highest embodied energy, then steel and finally concrete. Concrete would therefore be a more sustainable material from which to manufacture the pylon, however it is heavy and might present difficulties of erection in more rural locations. It might also be possible to use a modern composite material such as those being researched at present for use in pylon construction in Europe (Bystrup, n.d.).

The pylon will be located across the countryside at different sites. It might be necessary to construct a temporary access road or alternatively make use of a helicopter to supply and erect pylon parts. As a consequence, any design solution will need to be transportable in sections with the ability to be erected and assembled using a mobile crane and mobile elevated working platform. Different sections of the pylons might be fitted with lifting point or hooks to facilitate erection. It is likely that the ground conditions will vary at different sites, and to minimise foundation size and depth, as well as ensuring ease of transport/erection, a light structure is desired. Whilst the structure might be light it will also need to be strong. The pylon is to support an imposed load of 600 kN for the electrical catenary and wires at the end of each cross arm. It will also need to support its own self weight and be able to resist wind loading as well as any accidental loading. Wind loading will vary from site to site but can conservatively be taken as 1.2 kN/m². Accidental loading is much harder to predict, it might encompass in practice an impact from a vehicle or might be a much smaller load, such as that applied by cattle leaning on the mast.

A means of access to the pylon needs to be considered for maintenance. If a ladder or other means of access is fixed to the mast, then this will need to be tested at regular intervals under health and safety legislation. Really, it is probably better to limit the maintenance that a pylon will

require by appropriate specification of materials and finishes. For this reason I will not attach a ladder into my design. For example, if steel is used, this might be galvanised, and then polyester powder coated, to limit the requirement for routine maintenance. Typically, in the UK, existing 'L6' or 'L12' steel lattice pylons are repainted every 20 years. However, the painting of the cross arms and some sections of the pylon mast requires the electricity circuits to be switched off, so this is something that would ideally be avoided. Additionally, any routine maintenance due to the often, isolated locations of pylons, would need to be carried out from all terrain or four-wheel drive vehicles. Hence limiting the number of parts in a pylon is sensible, as less parts means less to go wrong.

Finally, as electricity pylons are tall structures often standing alone in a field or other open landscape position, they need to be protected from lightning strikes. There are a number of different methods available to protect a pylon from lightning strike. It is possible to fit the pylon with an air-terminating lightning protection system; this takes the form of a 2 to 8m high tapered metal rod which is connected to an earthing system. Alternatively, and perhaps more usually power lines have one or two grounded wires on top, which act as lightning rods which provide protection from lightning strikes.

Commentary

The candidate has demonstrated the application of comprehensive knowledge and understanding of design principles to prepare a design specification that meets most of the requirements of the project brief. The candidate's written response is structured in paragraphs with coherent points. There is relevant and supportive evidence throughout the written text of research reflected in the use of citations, references or specific examples in the text, e.g. the description of the Milliken Brothers pylon.

The specification has a logical structure between consecutive paragraphs and develops in detail the aspects required by the brief including the visual appearance of the pylon, selection of materials, applied loading, construction sequence, and method to protect the pylon from lightning strike.

The written response makes informed summary recommendations for different aspects of the design, for example providing methods for lightning protect technology such as an air terminating lightning protection system or use of electricity wire to ground the pylon. The candidate mainly uses accurate industry and technical terminology consistently throughout the specification.

1b) Annotated sketches

Candidate evidence

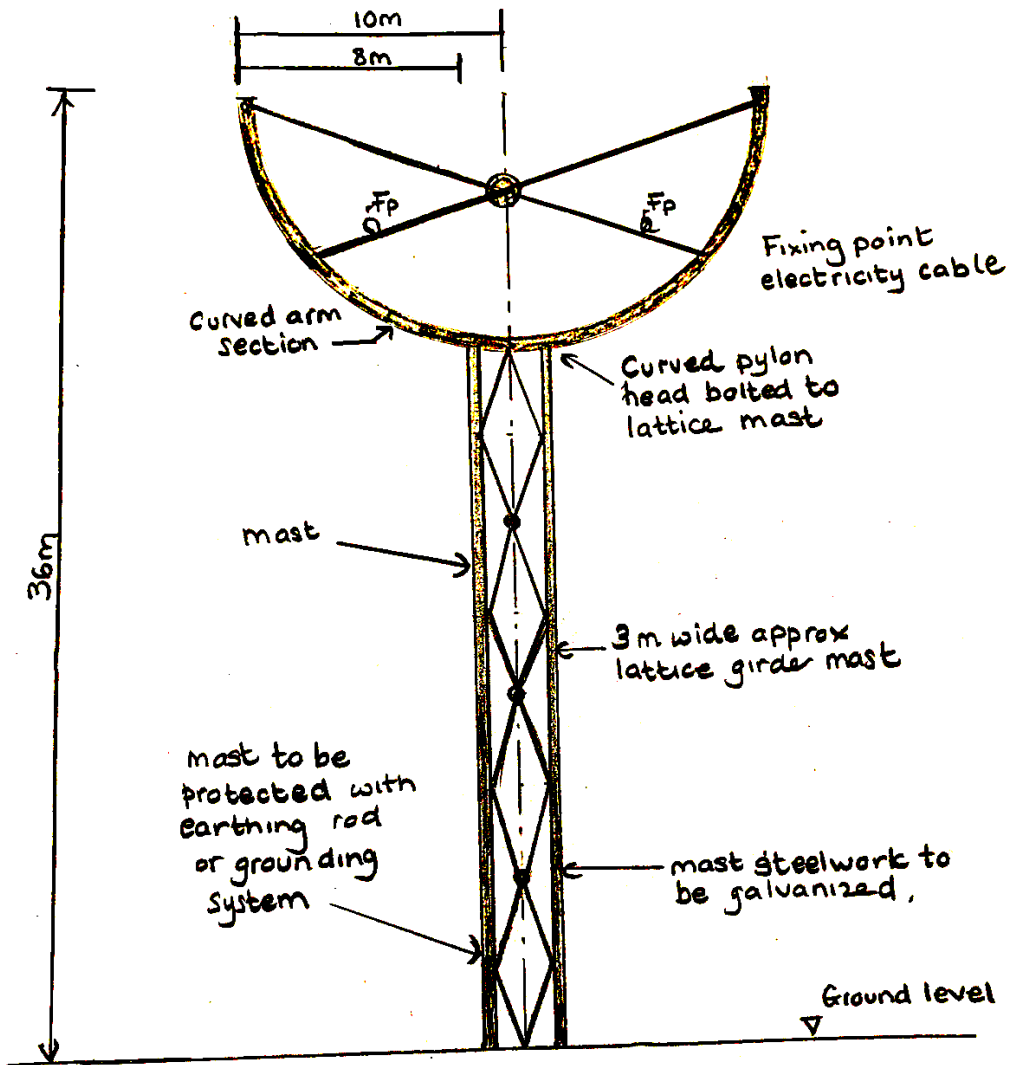

DESIGN ONE ELEVATION (SCALE 1:200)

Pylon lattice construction to be bolted together on site in sections.

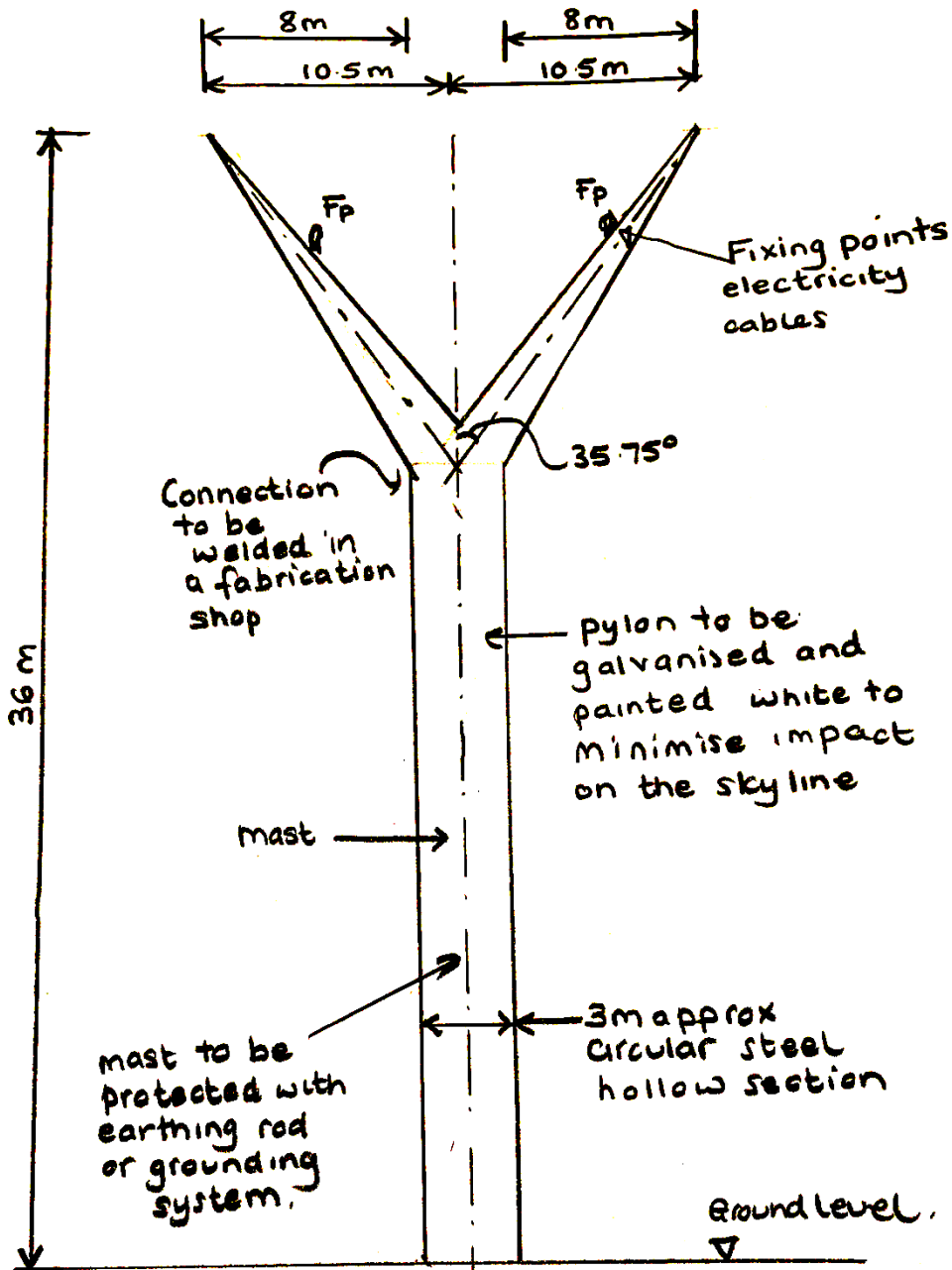

DESIGN TWO ELEVATION (SCALE 1:200)

Pylon to be erected in one section due to the complicated connection, fixing points of electricity cables to double as lifting points.

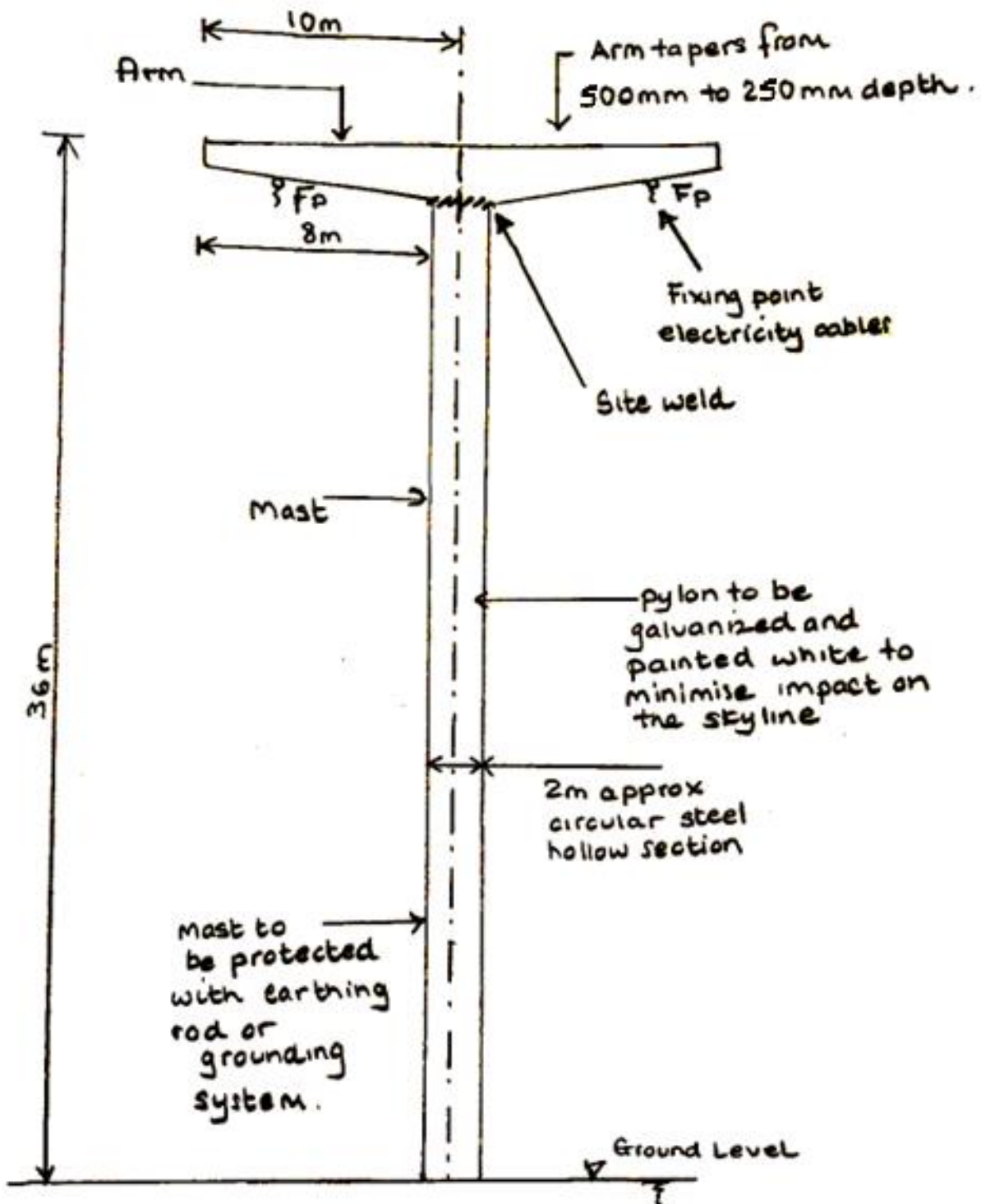

DESIGN THREE ELEVATION (SCALE 1:200)

Pylon to be erected in two sections, with lifting points attached to the mast and arm.

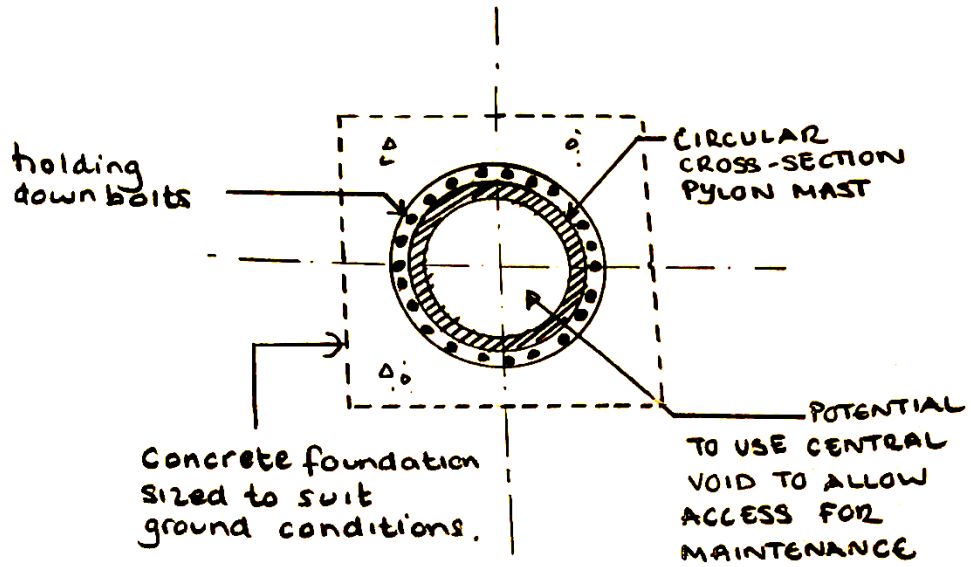

TYPICAL BASE DETAIL DESIGN TWO AND THREE (NOT TO SCALE)

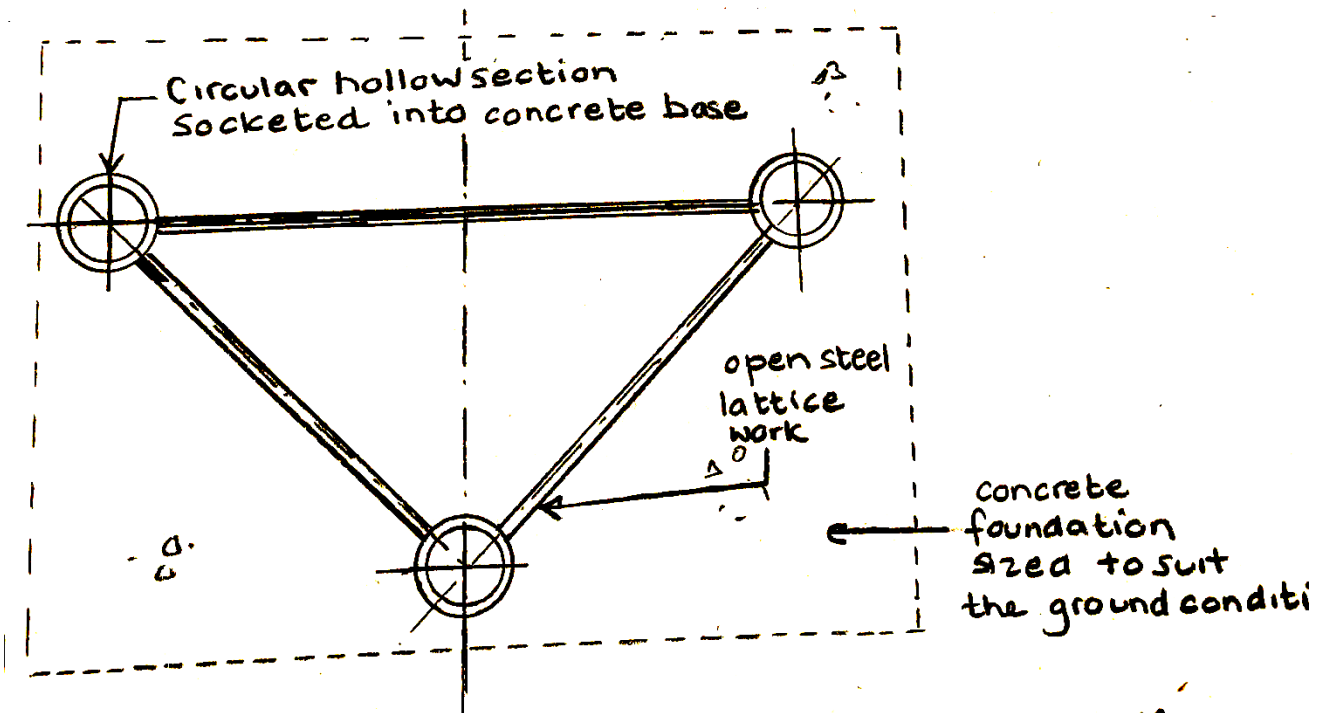

TYPICAL BASE DETAIL DESIGN ONE (NOT TO SCALE)

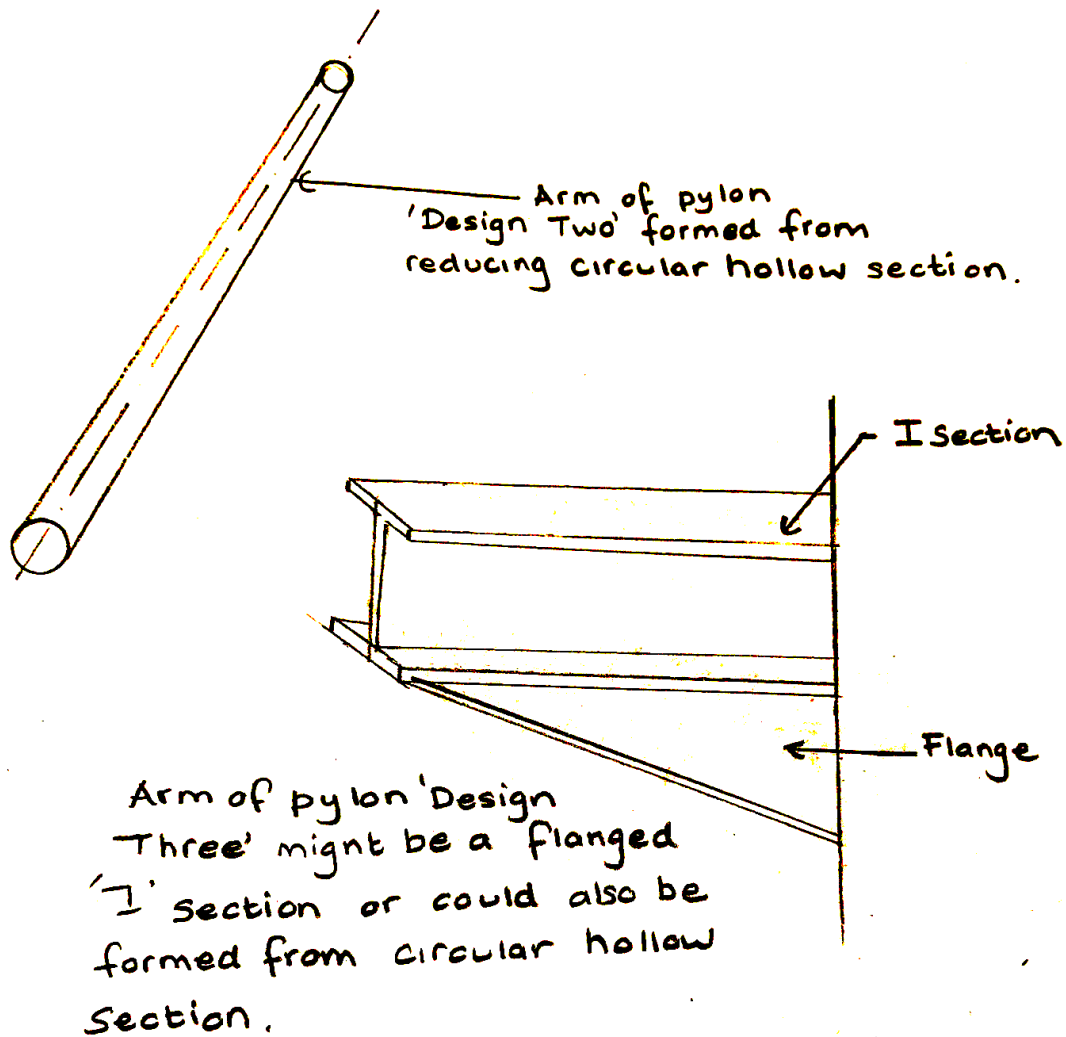

For 'Design One' the arms of the section will be constructed from steel plate.

POTENTIAL PYLON ARM DETAILS
(Not to scale)

Commentary

The candidate has demonstrated an excellent attempt at developing a range of design sketches. The sketches produced show that a range of different concepts have been considered which reflect the requirements of the design criteria.

The sketches are drawn proportionally and include an elevation of the pylon for each design option and base details. There is evidence of the candidate adopting the use of drawing conventions such as the use of a different line types for the centre line of the pylon mast.

The sketches are correctly dimensioned, identify the proposals for key components of the pylon, and provide details of the proposed materials, finishes and lightning protection system.

1c) Justification of the choice of one design for further development

Candidate evidence

After some consideration it is proposed that design three be further developed. The design makes use of steel circular hollow sections which are more modern in appearance, than the lattice mast section proposed for design one. This will make the pylon more aesthetically acceptable than the other options would.

One of the benefits of using a circular hollow section, is that if the diameter is large enough it might be possible to use the inside of the mast to maintain the pylon with the provision of a ladder or steps. The design is essentially a 'T' section and is the simplest to manufacture and install. This advantage will help with keeping the operational maintenance as limited as possible.

Design two also uses circular hollow sections, but the angled arms means that the connection to the mast is more complicated and will really need to be manufactured in one piece in a fabrication shop.

The 'T' section for design three can be erected in two pieces using a mobile crane, which satisfies the design requirement that it must be installed in this way. First the mast can be craned into position onto the foundation, and then the top 'T' section can be fixed into position and welded. The 'T' shape of the top section is symmetrical which helps with craning the element into position as the weight is evenly distributed. It will be possible to use slings around each of the pylon arms; with slings then attached to a lifting bar during erection with a crane.

Commentary

The candidate has prepared a written response in structured paragraphs that compares and contrasts different design options and then makes a clear recommendation for the selection of one option. They have demonstrated thorough understanding of the process by considering the steps that would be required to erect the pylon.

The justification is balanced, well-informed and makes reference to several specific aspects of the project brief and how the selected solution satisfies these options. For example, justifying why design three will be more aesthetically acceptable than the alternatives, or why their selected design will satisfy the requirement to keep the operational maintenance to a minimum. The candidate uses accurate industry language and technical terminology consistently throughout their response.

1d) Justification of the selection of the materials and components

Candidate evidence

It is proposed to use concrete for the foundation of the pylon and steel for the mast and arms. Concrete has low embodied energy, and both the size of the concrete foundation and strength of the concrete mix can be adjusted to accommodate the ground conditions at a particular site. Steel for the superstructure of the pylon has been selected as it is lighter than concrete but also strong; being good in bending it will resist the imposed and wind loading applied to the pylon.

As the pylon will be positioned externally, often in an exposed rural position, it will be necessary to protect the steelwork from corrosion. To minimise maintenance, it is proposed to first galvanise the steelwork of the pylon and then to apply a polyester powder coat in a light grey colour so that the structure merges into the skyline. It is important to limit the number of components used in the pylon as each one added creates a potential requirement for maintenance.

For this reason, it has been decided not to fit the pylon with an air-terminating lightning protection system, but to make use of a grounded wire on top of the pylon which will act as a lightning rod.

Commentary

The candidate has prepared a written response that justifies in detail the selection of specific materials and components for the pylon, explaining validly how these satisfy aspects of the project brief.

The candidate has considered how the selected materials meet the different requirements of the brief, for example to minimise the visual impact of the pylon on the skyline by selecting a light grey colour that blends in with the skyline. They have also recommended galvanising and powder coating the steel used in the mast and arms of the pylon, as this will protect it from corrosion and therefore meeting the brief requirement of limiting the operational maintenance and being resilient to all weather conditions.

The candidate has also demonstrated more thorough knowledge and understanding of material properties by proposing to limit the number of different components used, as this increases the risk of maintenance required in the future.

1e) Calculations

Candidate evidence

| | | |
|---------------------------|--|--|
| Project: 'T' Pylon | | Calculations by: Candidate A |
| | | Date: December 2021 |
| | | Page: 1 of 1 |
| Ref | Calculations | Results |
| EC3 | <p>Initial concept size of cross arm</p> <p>Load applied to cross arm:</p> <p>Imposed point load = 60 kN Dead load is the self-weight of arm (assumed) = 1.5kN/m Factored imposed loads = $60 \times 1.5 = 90$ kN Factored dead load = $1.5 \times 1.35 = 2.025$ kN/m</p> <p>Assume that the cross arm is cantilevering from the mast. Span of the cantilever is 8m. Biggest moment will occur at the point of connection. $B_{\max} = (90 \times 8) + (2.025 \times 8 \times 4) = 720 + 64.8 = 784.8$ kNm</p> <p>Select an initial size for the cross-arm section from the steel design 'blue book' available: https://www.steelforlifebluebook.co.uk</p> <p>Use 500 × 250 × 16 elliptical hollow section maximum bending resistance is 873 kNm in grade 355 steel.</p> <p>Initial concept size of mast</p> <p>As the 'T' shaped mast is symmetrical assume that moments applied from cross arms are equal and opposite.</p> <p>Height of mast = 36 m Assumed self-weight of steel mast section = 2 kN/m</p> <p>Axial imposed load applied to the mast from the cross arms $= 2 \times 60 = 120$ kN</p> | <p>Initial size of the crossarm is 500 × 250 × 16 elliptical hollow section</p> |

Axial dead load applied to the mast from the cross arms
= $1.5 \times 8 \times 2 = 24$ kN

Axial dead load self-weight of the mast
= $2 \times 36 = 72$ kN

Total dead load = $24 + 72$ kN = 96 kN

Total factored axial load
= $(120 \times 1.5) + (96 \times 1.35)$
= $180 + 129.6$
= 309.6 kN say 310 kN

To find an initial concept section size for the mast, model as a slender cantilever member fixed at the base, subject to a critical buckling load.

$$P_{cr} = \frac{\pi^2 EI}{kL^2}$$

E = Young's modulus = assume 210 kN/mm²

P_{cr} = 310 kN

L² = 36000² = 1.296 × 10⁹ mm²

k = 2.1 for a cantilever

Find I

$$I = n \frac{P_{cr} k L^2}{E \pi^2}$$

$$I = \frac{310 \times 2.1 \times 1.296 \times 10^9}{210 \times \pi^2}$$

$$I = \frac{8.43696 \times 10^{11}}{2072.62}$$

I = 407067383.3 mm⁴ or 40706.74 cm⁴ say 41 cm⁴

Select an initial size for the cross-arm section from the steel design 'blue book' available:

<https://www.steelforlifebluebook.co.uk/>

Use 457 × 14.2 Circular Hollow Section with I = 48,500 cm⁴ in grade S355 steel.

The initial size of the mast is 457 × 14.2 circular hollow section.

Commentary

In the calculations, the candidate provides an estimate of the initial concept sizes for the main mast and cross arms of the pylon which is sensible.

The candidate has demonstrated their ability to accurately calculate the applied bending moment at the fixed end of the cantilevering cross arm and the axial compressive load applied to the mast. The candidate has estimated the loading and has followed calculation conventions by using partial factors of safety. The candidate has used the steel 'blue book' to then select appropriate initial members for the pylon structure.

Overall, the calculations are correct and accurate, and the methodology is correctly applied throughout all the calculation steps. The candidate has followed industry standards and conventions and the presentation of the calculations is clear.

1f) Engineering drawings of the proposed design

Candidate evidence

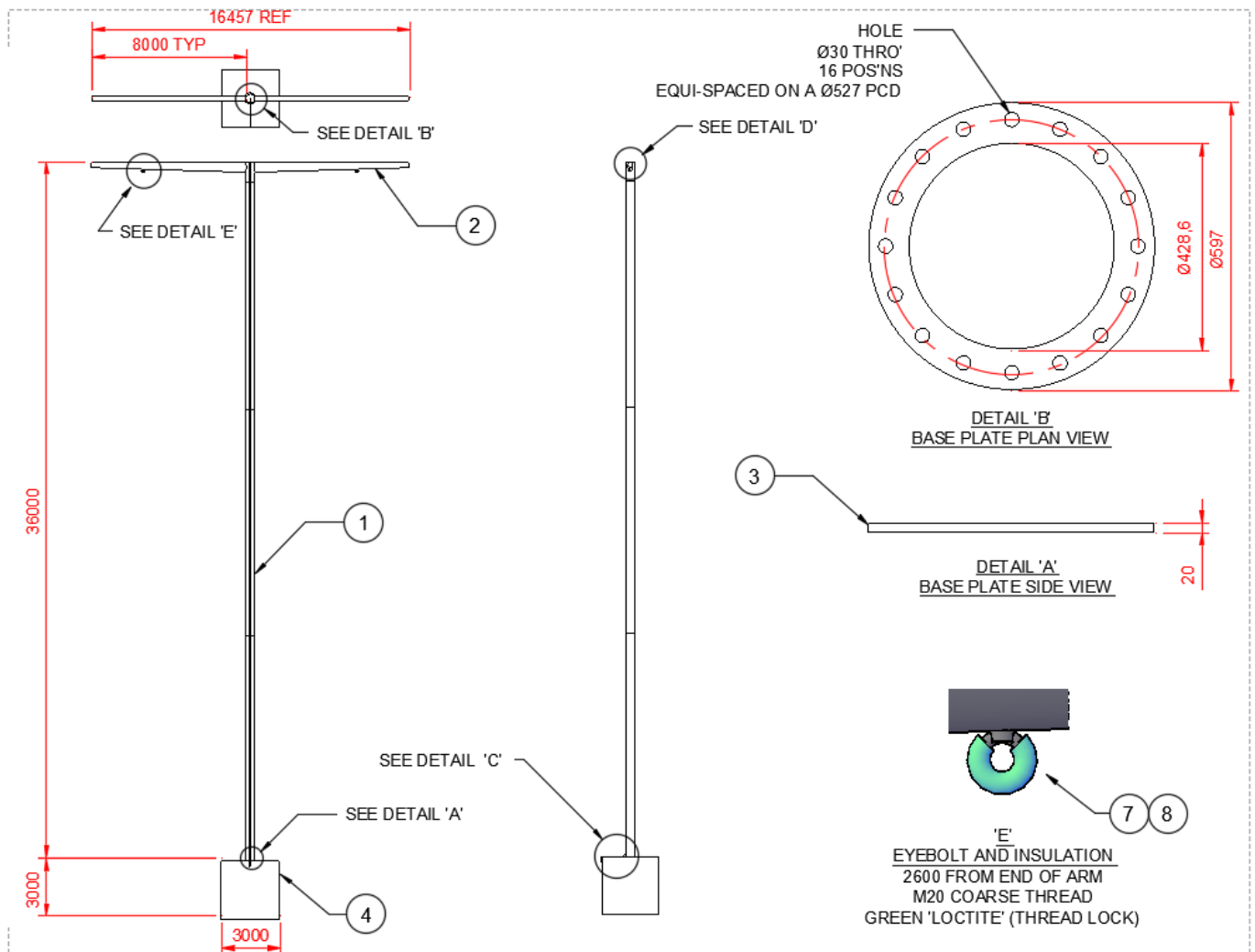

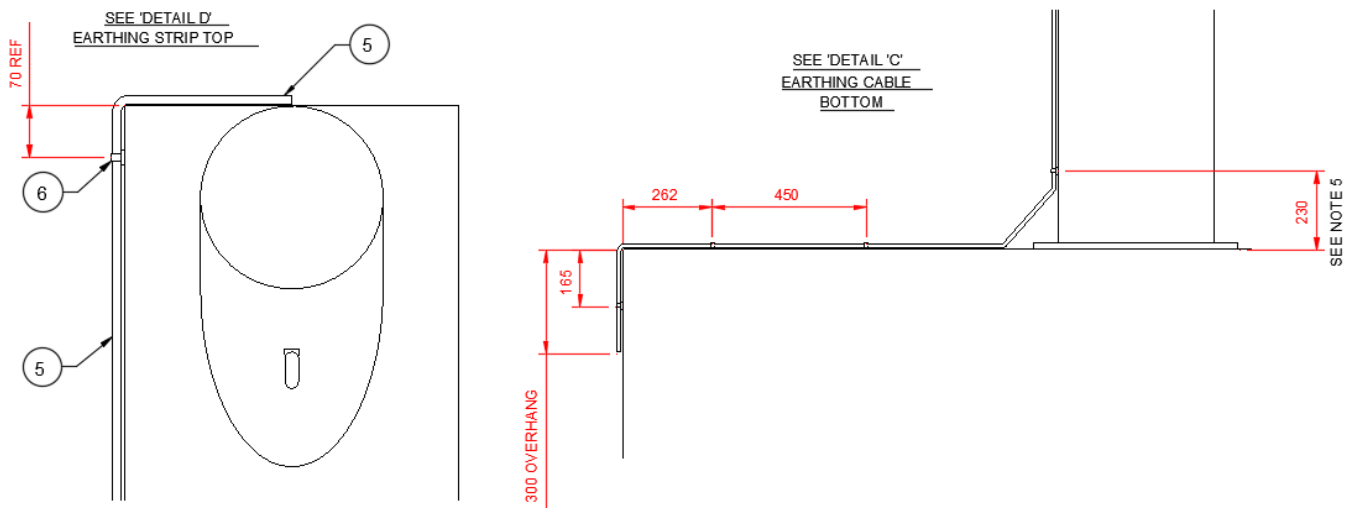

| PARTS LIST | | |
|---------------|---------------|----------|
| BALLON NUMBER | ITEM | QUANTITY |
| 1 | MAST | 1 |
| 2 | CROSS ARM | 2 |
| 3 | BASE PLATE | 1 |
| 4 | CONCRETE BASE | 1 |

| | | |
|---|-----------------------------------|-----|
| 5 | EARTHING CABLE - Ø12mm | 40M |
| 6 | NYLON ADJUSTABLE (>17MM) CLAMP | 11 |
| 7 | EYEBOLT | 2 |
| 8 | INSULATION | 2 |

NOTES:

1. ALL DIMENSIONS ARE IN MM
2. ITEM 1 - MAST: Ø457 x 14.2 CHS
3. ITEM 2 - CROSS ARM: (500 x 250 x 16) TO (Ø250 x 16) ELLIPTICAL TO CIRCULAR CROSS SECTION
4. END OF EARTHING CABLE TO BE WELDED TO THE TOP OF THE MAST ON SITE
5. ITEM 6 TO BE POSITIONED AS SHOWN, THEN IN EQUAL SPACINGS OF 5100MM APART

Commentary

The candidate has prepared scaled drawings of the selected design of the pylon using a CAD package, including an elevation and base plate detail for the selected option.

The drawings have been well-designed and are generally correctly dimensioned and identify the key components of the pylon, providing details of the proposed materials and finishes that are intended to be used. The approach to the drawings means that they are clearly presented in a way that would mean that they could be used by a third party to develop the presented design, without having to require significant additional information.

The drawings have been developed closely following industry drawing drafting standards, for example each has notes, a drawing frame and title block.

1g) Outcomes of the virtual modelling of the proposed design

Candidate evidence

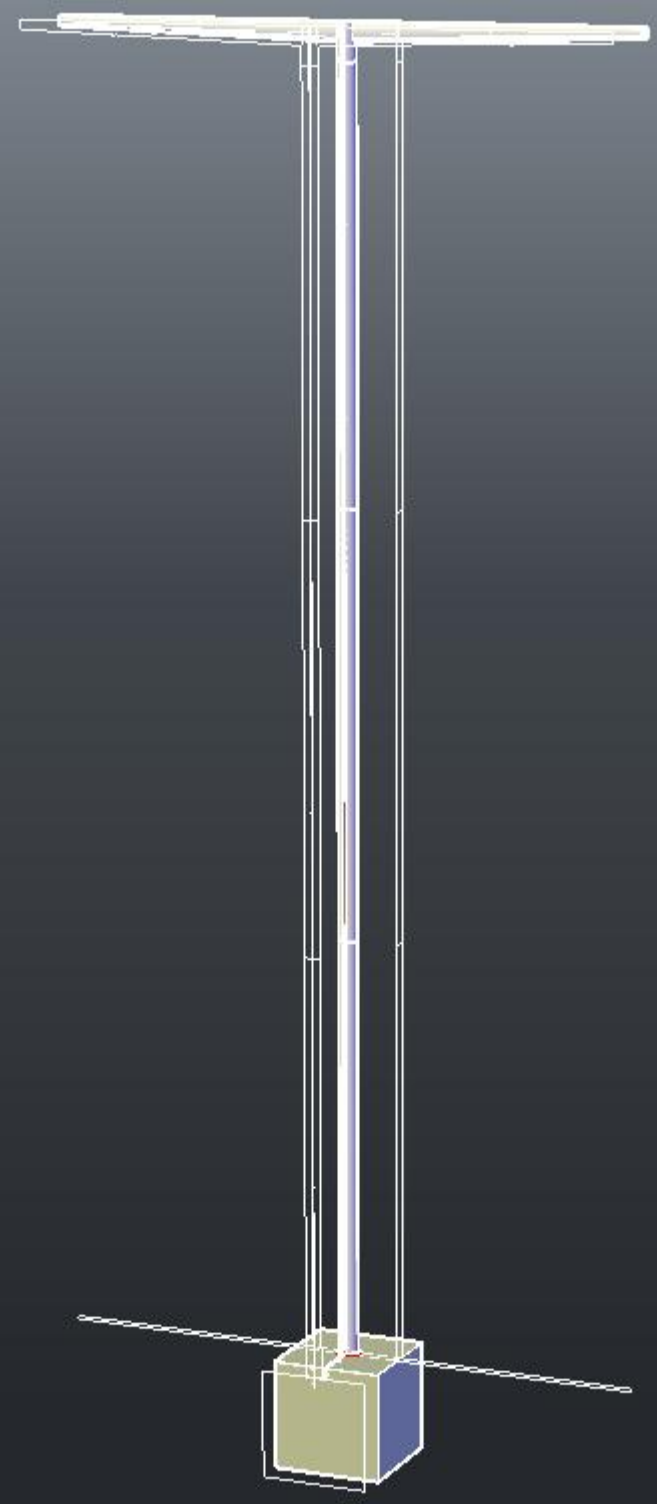

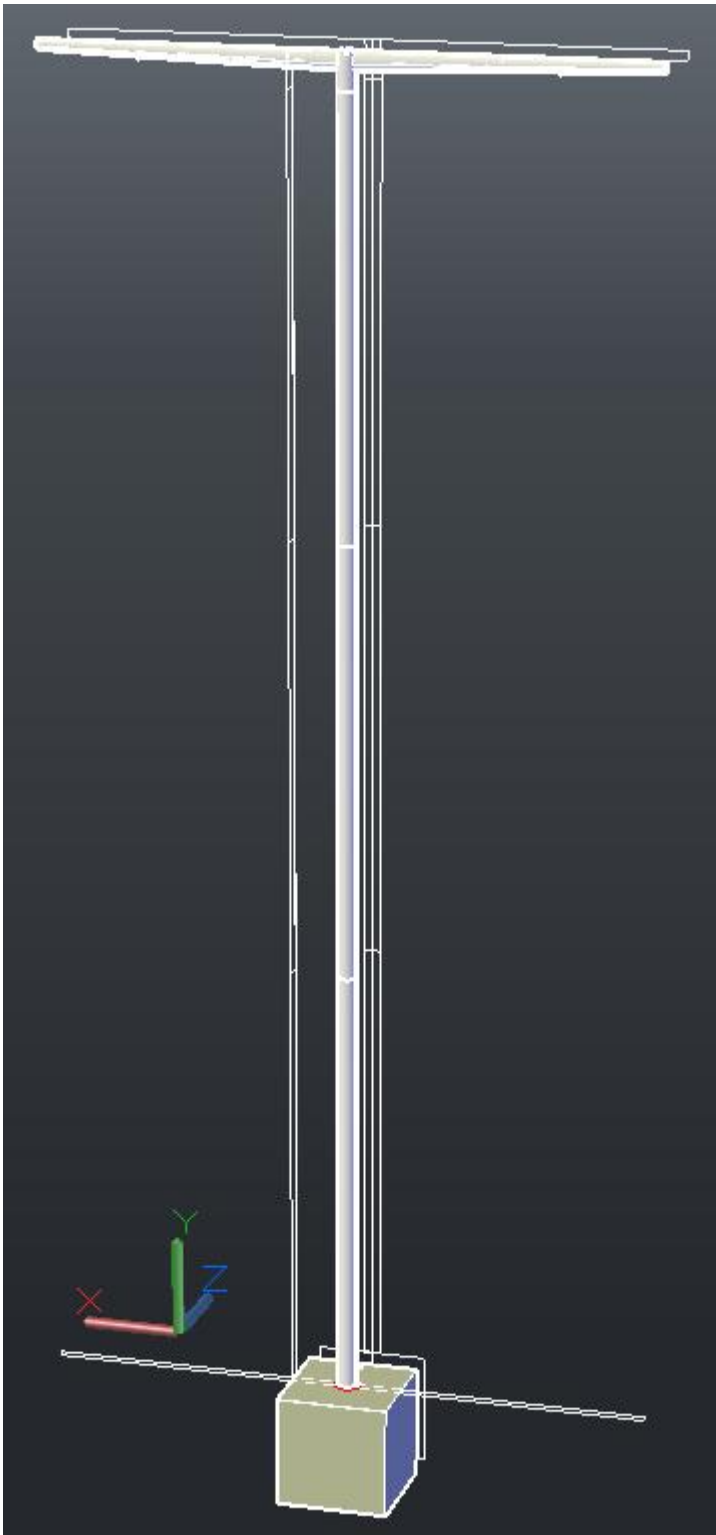

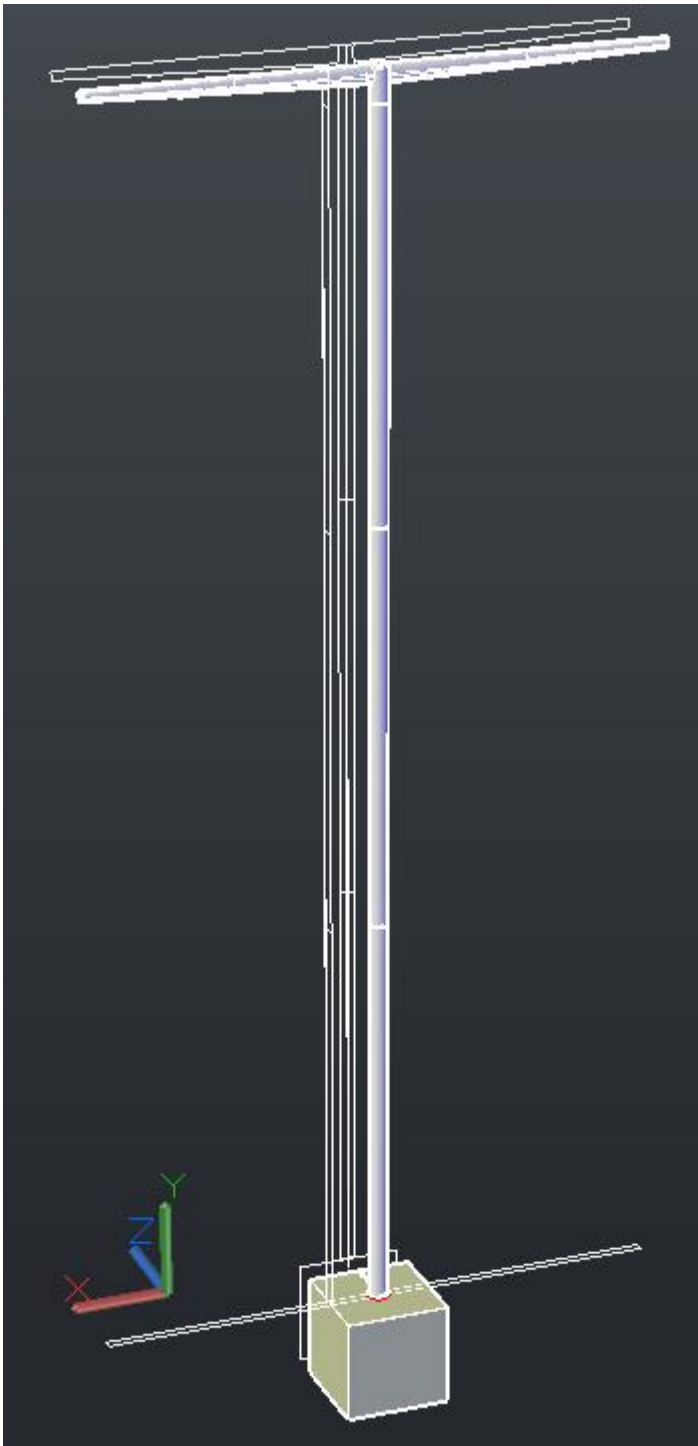

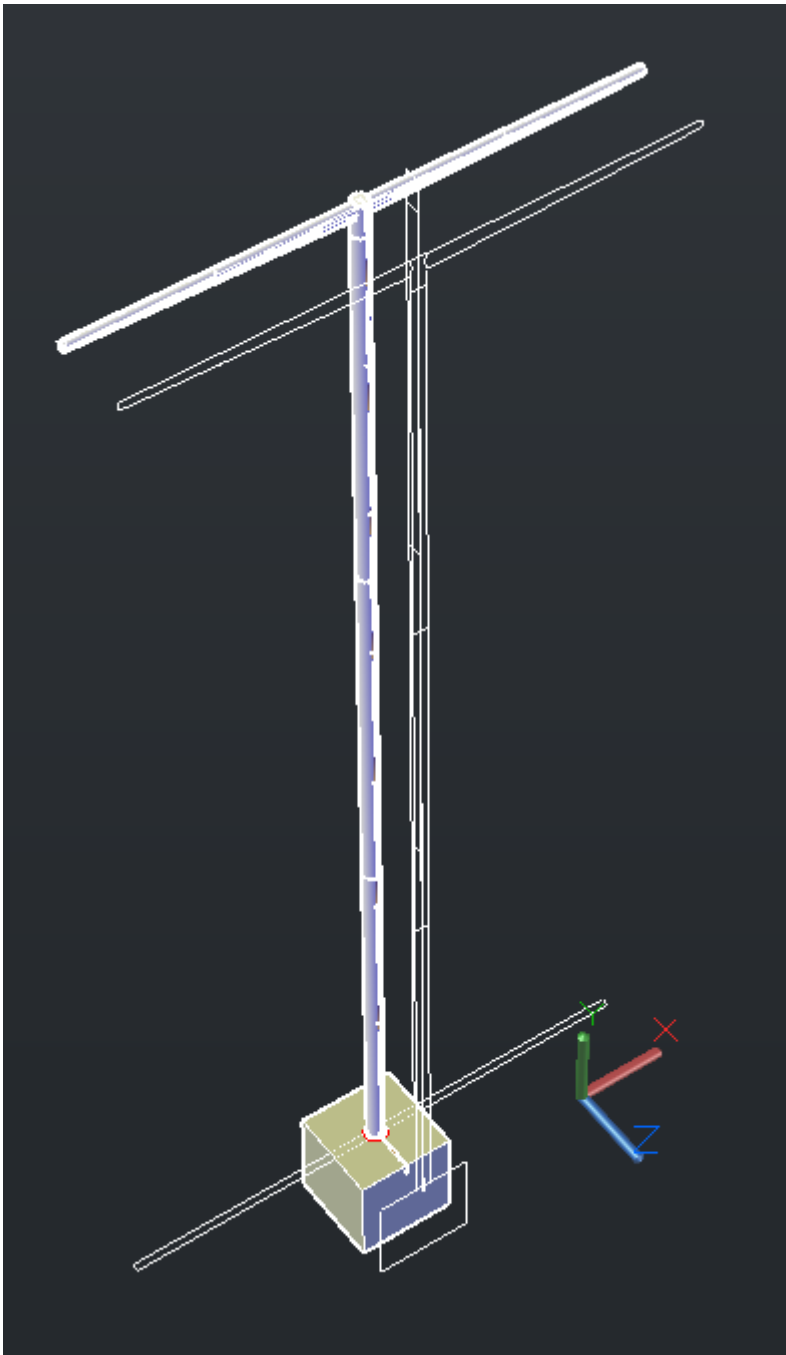

Video showing the 3D model in AutoCAD:



Structural 3D model
Distinction.mp4

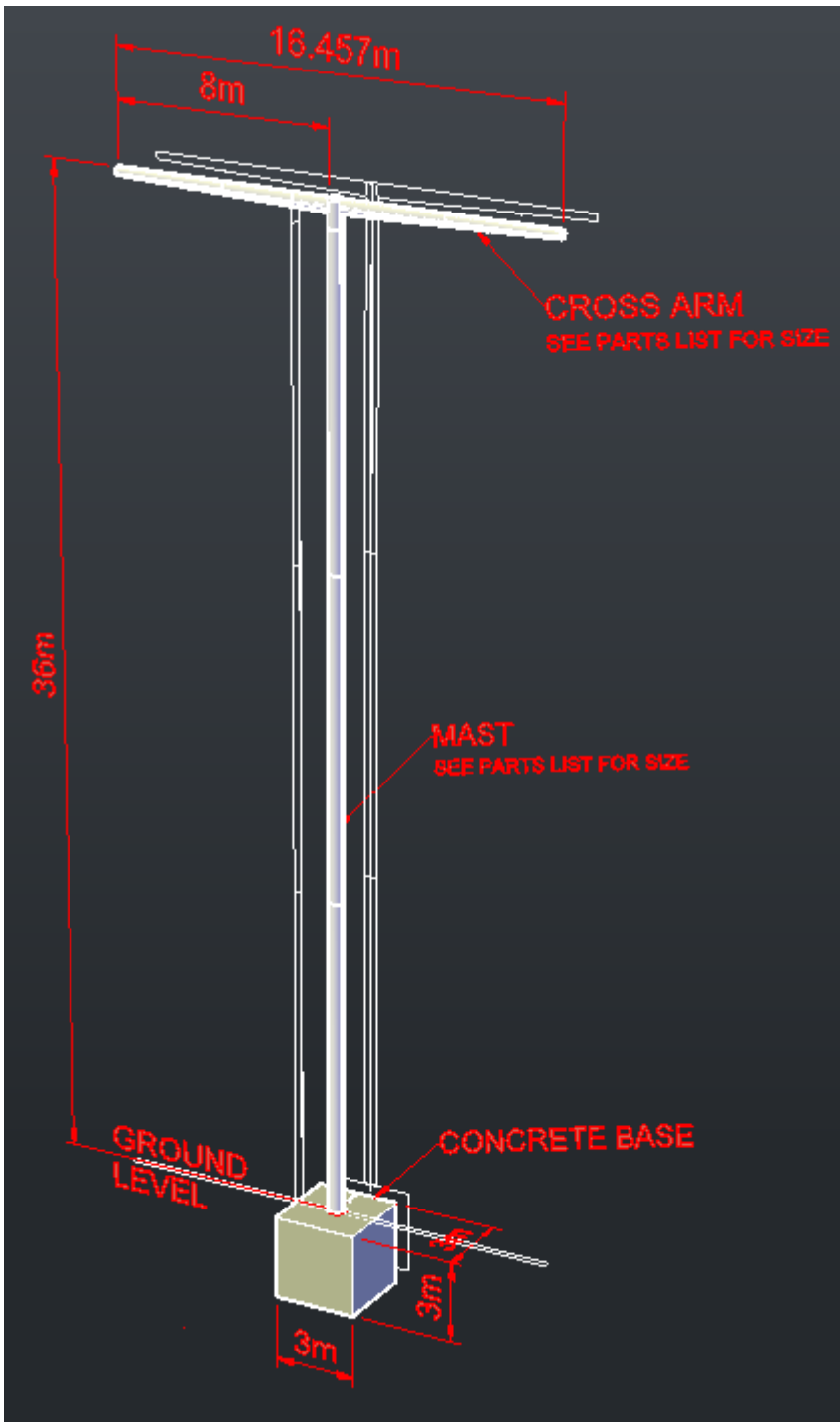

ISOMETRIC VIEW

ISOMETRIC VIEW
TOP OF PYLON

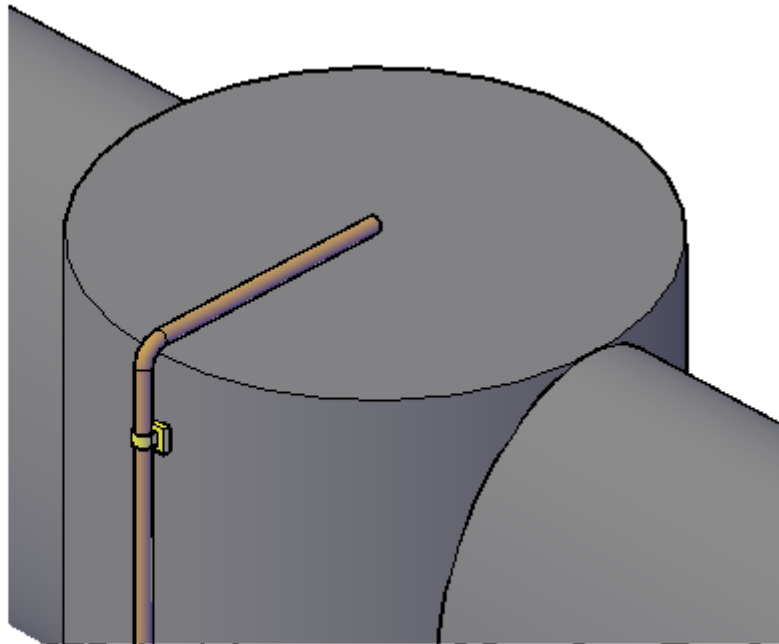

ISOMETRIC VIEW
BOTTOM OF PYLON

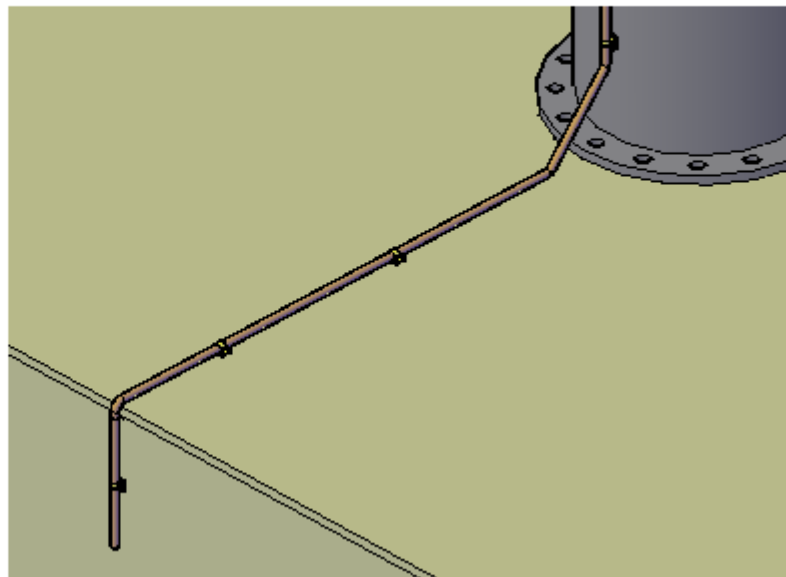

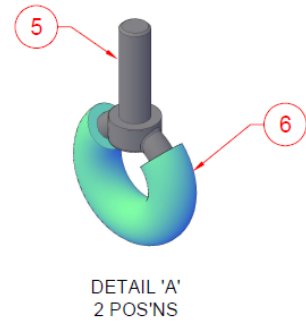
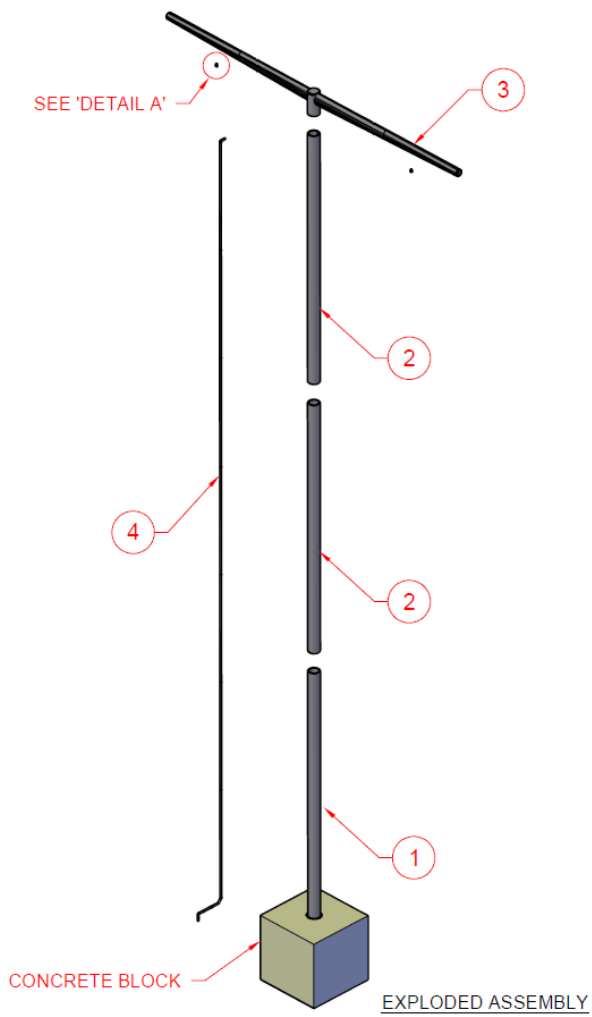

NOTES:

1. ITEMS 1, 2 AND 3 TO BE WELDED ONSITE
2. ALL DIMENSIONS ARE IN MM

| PARTS LIST | | |
|-------------|---------------------------|----------|
| BALLOON No. | ITEM | QUANTITY |
| 1 | MAST SECTION 1 | 1 |
| 2 | MAST SECTION 2 | 2 |
| 3 | CROSS ARM ASSEMBLY | 1 |
| 4 | EARTHING ASSEMBLY | 1 |
| 5 | EYEBOLT | 2 |
| 6 | NYLON INSULATOR 4MM THICK | 2 |



Digital image of the pylon positioned in a typical British rural landscape

Rural image source: <https://www.britannica.com/place/Ashfield-district-England>



Digital image of the pylon positioned in an urban landscape

Urban image source: <https://www.microdesk.com/articles/5-ways-3d-city-models-plan-a-better-tomorrow-for-urban-communities/>

Commentary

The candidate has used software to prepare a 3D model of their proposed pylon depicting the relationship of the principal components of the mast and arm.

The 3D model includes multiple viewing angles of the design, and the candidate has also included a video demonstrating the different viewing angles of the 3D model.

Additionally, several isometric views of the pylon are included, which contain all the relevant dimensions and a good amount of clear and informative annotations, as well as close up views of details of the design.

An exploded view of the pylon's assembly is also included, which provides a clear overview of the construction of it, the different sections and how they are assembled together. The exploded assembly view contains detailed and helpful annotations, as well as a parts list.

The candidate has developed 3D images, which simulate the pylon positioned in a rural and urban landscape, demonstrating that the design meets the required design criteria. The 3D images are proportionally correct.

1h) Bill of materials

Candidate evidence

| Item | Description | Unit | Quantity | Rate per Unit (£) |
|------|---|----------------|-------------------------|-------------------|
| 1 | Provision and installation of 147 × 14.2 circular hollow section, in Grade 355 steel. Galvanised and finished with a polyester powder coating. Colour light grey. | m | 36 | |
| 2 | Provision and installation of 500 - 250 × 16 elliptical tapered hollow section, in Grade 355 steel. Galvanised and finished with a polyester powder coating. Colour light grey. | m | 18 | |
| 3 | Excavation for concrete pad foundation maximum depth 3 m | m ³ | To be confirmed on site | |
| 4 | Provision and placement of RC40 concrete in foundation pad. | m ³ | To be confirmed on site | |
| 5 | Grade 8.8 M28 holding down bolts. | 1 no | 16 | |
| 6 | Completion of full penetration butt weld. | hr | To be confirmed on site | |
| 7 | Insulated multi core wire to act as lightning protection | m | 38 | |

Commentary

The candidate has prepared a bill of materials laid out in a manner reflecting industry standards including, for example, columns covering 'item', 'description', 'unit' and 'quantity'. The candidate has also included a 'rate' column, but this has not been populated. The bill of materials is accurate and contains all the materials, components and consumables needed to construct the pylon.

The items listed are detailed and include technical information, for example specific types of bolts, or the colour information for the steel that is needed for the elliptical hollow section.

The candidate has itemised the principal pylon materials and associated activities that are to be undertaken for the construction and erection of the pylon. For example, the excavation of a foundation or provision of steelwork for the mast.

Notes of research undertaken

Recently a new design of pylon has been developed by the National Grid referred to as the T-Pylon 186 (Hewitt, 2015).

The typical loads applied to structures such as pylons and the desired design life are covered in Eurocode 1 (European Standard, 1991).

Pylons which carry electricity at above 100 kilo volts are typically spaced at 150 to 300 m (Quora, n.d.)

The first pylon was developed in 1930s for the Central Electricity Board by American designers the Milliken Brothers (Glancey, 2011)

References

Bystrup (n.d.) Power pylons of the future – European Composite Pylon. [Online] Available at: <https://www.compositepylon.com/> (Accessed 18th December 2021)

European Standard (1991) Eurocode 1: Actions on Structures – Part 1-1: General actions – Densities, self-weight, imposed loads for buildings. European Committee for Standardisation, Brussels [Online] Available at <https://www.phd.eng.br/wp-content/uploads/2015/12/en.1991.1.1.2002.pdf> (Accessed 18th December 2021)

Glancey, J (2011) Loved and loathed – the armoured knights of the National Grid. Guardian [Online] Available at <https://www.theguardian.com/artanddesign/2011/may/22/national-grid-pylons-design> (Accessed 18th December 2021)

Hewitt, A (2015) Britain's first new electricity pylons in 100 years are unveiled – and they look very different. The Mirror. [Online] Available at: <https://www.mirror.co.uk/news/uk-news/britains-first-new-electricity-pylons-5497708> (Accessed 18th December 2021)

National Grid (2021) Everything you ever wanted to know about electricity pylons. National Grid [Online] Available at: <https://www.nationalgrid.com/stories/energy-explained/everything-you-ever-wanted-know-about-electricity-pylons#:~:text=Pylons%20are%20used%20to%20support,to%20our%20homes%20and%20businesses.&text=Increasing%20the%20voltage%20allows%20for%20greater%20efficiency%20with%20less%20energy%20loss.> (Accessed 18th December 2021)

Quora (n.d.) What is the distance between electricity pylons? [Online] Available at [https://www.quora.com/What-is-the-distance-between-electricity-pylons#:~:text=For%20distribution%20structures%20\(35%20kV,at%20the%20higher%20voltage%20levels.](https://www.quora.com/What-is-the-distance-between-electricity-pylons#:~:text=For%20distribution%20structures%20(35%20kV,at%20the%20higher%20voltage%20levels.) (Accessed 18th December 2021)

Terna (n.d) Terna Pylon- Towards the grid of the future: design, innovation and technology at the services of the environment, Terna Group. [Online] Available at: https://renewables-grid.eu/fileadmin/user_upload/Files_RGI/Event_material/Grid_Aesthetics/BESTGRID_INSPIRE-Grid_Grid_Aesthetics_Terna.pdf (Accessed 18th December 2021)

Task 2 – Manufacture and test

(Assessment themes: Health and safety, Manufacturing, Reports)

For task 2, candidates need to produce the following pieces of evidence:

- a) risk assessment
- b) prototype
- c) test records.

Additional evidence of candidate performance that must be captured for marking:

- assessor observations:
 - development of scaled prototype.
 - testing.

Photographic evidence which shows:

- results of tool selection and usage (photograph 1)
- cutting and preparation of model components (photographs 2-3)
- connecting of model components (photograph 4-6)
- arrangement of model components in plan, elevation and detail (photographs 6-10)
- 3D view of the final prototype (photographs 11-12).

2a) Risk assessment

Candidate evidence

| Hazard | Risk | Control | Likelihood | Severity |
|---|--|--|------------|----------|
| Mechanical equipment used in the manufacturing of the prototype pylon | Contact injuries e.g. Entanglement, drawing-in, abrasions, cuts, burns | <ol style="list-style-type: none"> 1. Access to the workshops is strictly restricted to authorised personnel only. 2. No one may operate workshop equipment unless they have received sufficient training and permission from the technician-in-charge. 3. Specific risk assessments must be completed for each piece of mechanical equipment used to manufacture the pylon. 4. Generic risk assessment for power hand tools must be completed and safe systems of work issued to operatives. 5. Guards on the machines must be used. 6. All workshop equipment must be regularly maintained and serviced. 7. Long hair must be completely covered, and suitable eye protection worn. | 3 | 3 |
| Electrical equipment used in the manufacturing of the prototype pylon | Electric shocks or burns from using faulty electrical equipment | <ol style="list-style-type: none"> 1. All portable electrical equipment must be tested at for electrical safety at correct intervals and labelled with the date of the test. 2. Electrical equipment used for the manufacture of the pylon must be calibrated. 3. Electrical cables and plugs should be regularly visually inspected by the user for damage. 4. Any defective equipment should be reported to the technician-in-charge and taken out of use until the repair has been affected. 5. Electrical equipment must always be operated in accordance with manufacturers' instructions. | 3 | 3 |
| Manual handling of heavy / bulky objects needed for the production of the | Back injuries | <ol style="list-style-type: none"> 1. A risk assessment must be completed for lifting heavy and bulky loads that present a risk of injury. 2. Training in lifting techniques must be provided for workshop staff | 2 | 1 |

| | | | | |
|--|--|--|---|---|
| prototype pylon | | <p>who undertake the lifting of heavy parts of the pylon.</p> <ol style="list-style-type: none"> Appropriate PPE for lifting operations must be worn. Lifting equipment must be registered with a Centre's insurers and annual inspections carried out. Records of the inspections must be kept in the safety file. | | |
| Hazardous substances used in the finishing of the prototype pylon, such as painting the prototype. | Irritating vapours, skin sensitisation, dermatitis | <ol style="list-style-type: none"> A COSHH risk assessment must be completed for using substances that may present a hazard to health. A Material Safety Data Sheet (MSDS) must be kept together with a risk assessment for each type of paint in the Workshop Safety File for future reference. All containers used for storage of hazardous and non-hazardous substances must be suitably labelled indicating their contents. | 1 | 1 |
| Slips and trips in the work area when producing and testing the prototype | Injuries | <ol style="list-style-type: none"> Workshop working areas must be kept clear of obstructions and the floor must be kept free from oil and swarf. Any spillages should be cleaned up immediately. Any hazards such as trailing cables, defects to floor coverings and faulty lighting etc. should be reported immediately to the technician-in-charge. All areas well lit. | 2 | 1 |
| Fire caused by a range of electrical equipment and flammable substances | Burns, smoke inhalation | <ol style="list-style-type: none"> Equipment should be switched off when not in use for long periods. All portable electrical equipment must be tested for electrical safety at correct intervals and labelled with the date of the test. Flammable substances must be kept away from naked flames and ignition sources. Flammable substances must be kept in an appropriate fire-resistant metal cabinet. The fire alarm system is installed, maintained and tested. Workshop users must be acquainted with the Fire Routine Procedure for the building. Fire Stewards must be appointed to cover the workshop area. | 2 | 4 |

| | | | | |
|---|---|--|---|---|
| Use of welding equipment within production of the prototype | Injury, particle inhalation, eye damage | <ol style="list-style-type: none"> 1. Ensure the welder is properly installed and grounded. 2. Maintain adequate ventilation. 3. Use eye protection and wear fire retardant clothing. | 2 | 4 |
|---|---|--|---|---|

| Likelihood | | Severity | |
|------------|-------------------------|----------|------------------------|
| 1 | Very unlikely to happen | 1 | Minor injury |
| 2 | Unlikely to happen | 2 | Major injury |
| 3 | Possible to happen | 3 | Loss of limb |
| 4 | Likely to happen | 4 | Death of an individual |
| 5 | Very likely to happen | 5 | Multiple deaths |

Commentary

The candidate has produced a clear and thorough risk assessment for the construction of the pylon, that identifies hazards, risks, risk classification, and suggests control measures for each category.

Each of the hazards identified lists the main risks associated with it.

The candidate has fully considered the likelihood and severity of injury caused by each hazard, and they have also provided a chart to explain the likelihood and severity scores.

There are multiple recommended control measures for each risk, that are all detailed and comprehensive. This demonstrates that the candidate has considered a range of situations and scenarios and associated risks when undertaking different steps of the construction of the prototype.

2b) Manufacture of the prototype

Candidate evidence

I am manufacturing a scaled prototype, at a scale 1:50.

I used copper to manufacture the scaled prototype, because it is a resource readily available at the college and more cost effective than using steel for the whole prototype, as well as being a very suitable material for a prototype build.

However, I used grade 355 steel for the testing, which is the actual material I recommended for the manufacture, because I needed the testing to be done to the same material to get realistic results.



Photograph 1 shows the tools, equipment and PPE the candidate has selected for the task. All required items have been gathered and arranged in a logical sequence to reflect the work to be undertaken. The candidate has ensured their sketches with the scaled dimensions is close to hand prior to starting work.

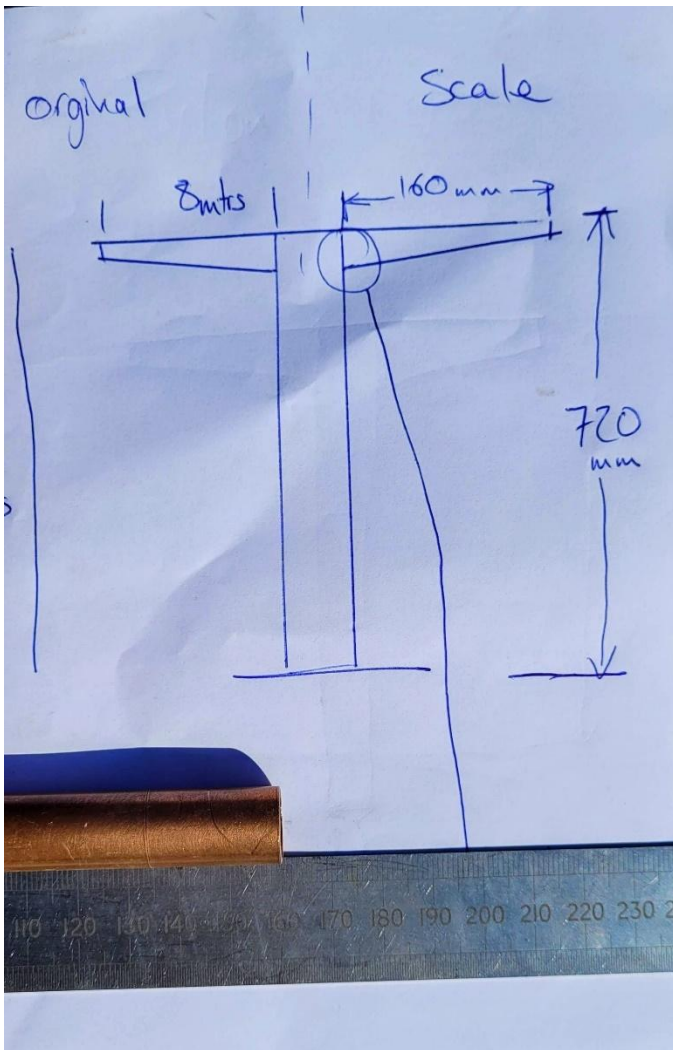

Photograph 2 shows the arm cut to length against a steel rule. The length is accurate at 160 mm, at the same length as the calculated length in the sketch.

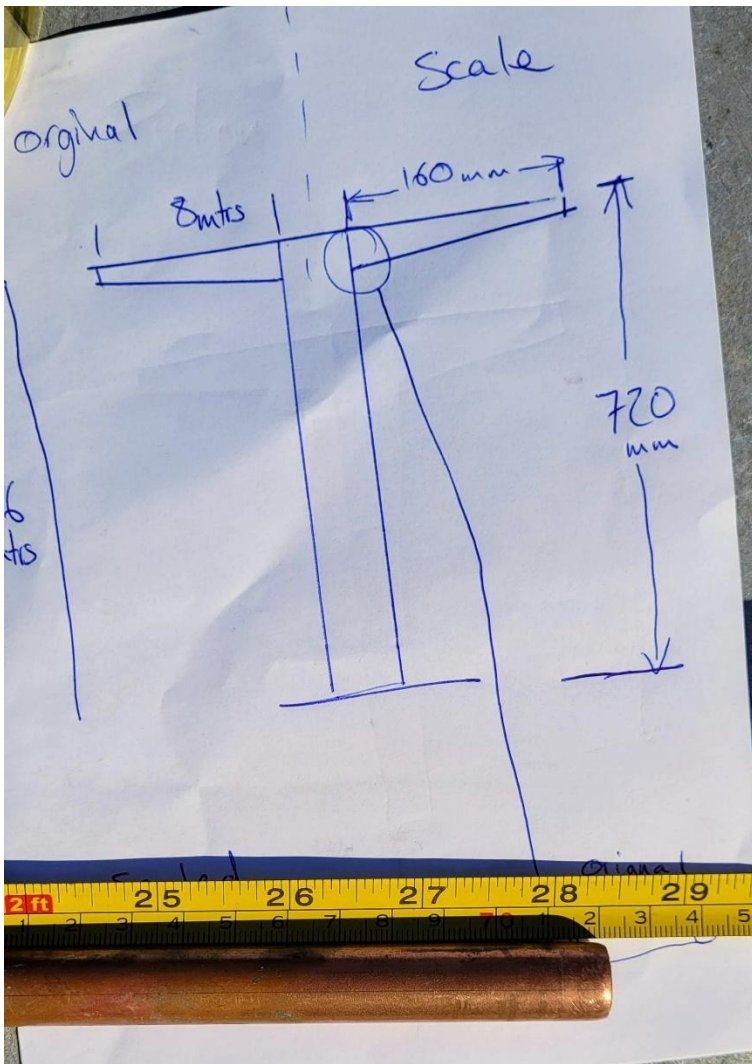

Photograph 3 shows the mast cut to length against a tape measure. The length is accurate at 720 mm, at the same length as the calculated length in the sketch.

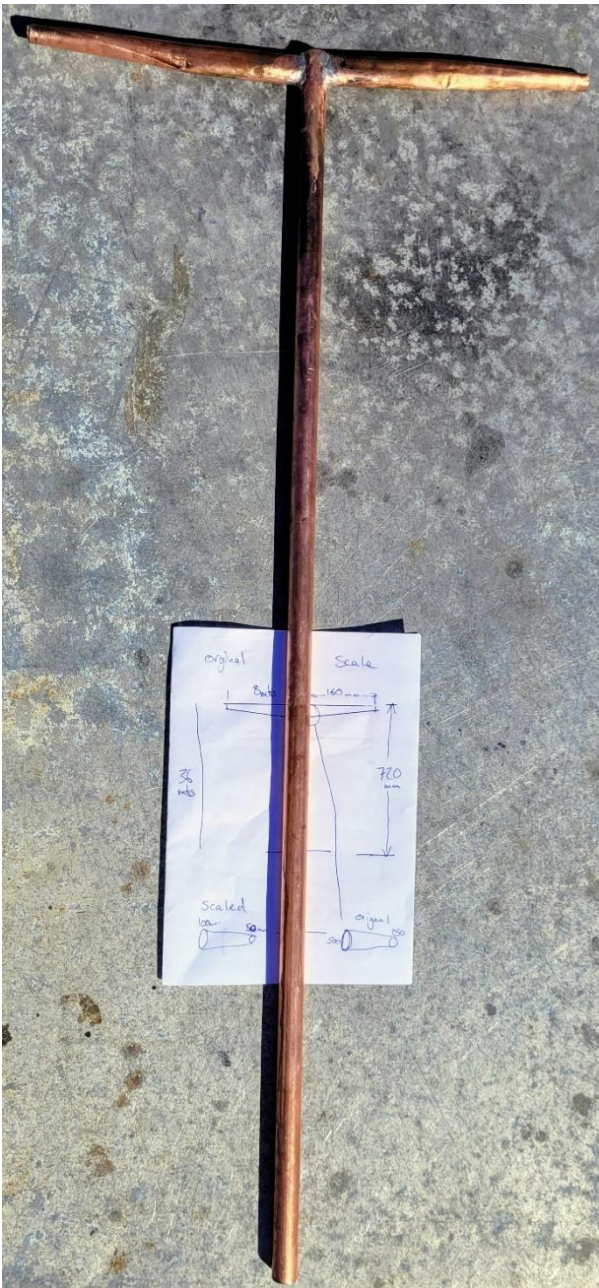

Photographs 4 and 5 show the soldered connection of the components of the prototype. The soldering is of good quality and the candidate is referring to the sketch to ensure the parts are connected as designed.



Photographs 6 and 7 show the completed soldered joins of the prototype, demonstrating the taper of the arms. The candidate is using a tape measure to show the accuracy of the length.



Photographs 8 and 9 show attention to detail, with the joints and lightning cable soldered into position.

Photograph 10 shows a bird's eye view from above, including lightning protection.



Photograph 11 shows the finished pylon painted to a grey high-quality finish.



Photograph 12 shows the insulation fitted to the cable fixings.

Practical observation form – Prototype

| | |
|-----------------------|------------------------------------|
| Assessment ID | Qualification number |
| 8714-324 | 8714-34 |
| Candidate name | Candidate number |
| Candidate A | CG12345 |
| Centre name | Assessment theme |
| City & Guilds | Health and Safety Manufacturing |

Complete the table below referring to the relevant marking grid, found in the assessment pack. **Do not** allocate marks at this stage.

| | |
|------------------|---|
| Task | Notes – <i>detailed, accurate and differentiating notes which identify areas of strength and weakness are necessary to distinguish between different qualities of performance and to facilitate accurate allocation of marks once all evidence has been submitted.</i> |
| Prototype | <p>The candidate entered the workshop and located a workspace to setup for the task. The selected workspace had ample room and was close to the larger items of equipment that were going to be used for the task. The candidate discussed with others in the workshop that they needed to use these items of equipment and alerted them to the activity that they were preparing to undertake. The candidate then collected the range of tools, equipment and PPE needed to undertake the task. These items were closely checked for working condition, and calibration checks were undertaken. The equipment was then placed neatly in the workspace and was arranged in a logical sequence based on the work to be undertaken.</p> <p>The candidate collected a number of technical documents, including their design information and the risk assessment and ensured this could be accessed through the work task. The documents were placed within reach, but not in a way where they would interrupt the task. The candidate did a visual check of the immediate workspace, and of the areas where they would need to access to work. An obstruction in one of the walkways was removed to avoid a trip hazard. The candidate placed a waste bin close to their workstation – making sure it did not present a trip hazard. Finally, the candidate reviewed the risk assessment and checked that all controls had been executed, before starting work on the prototype.</p> <p>The candidate undertook the construction of the prototype, ensuring that they referred regularly to their initial design specification and diagrams. The prototype was assembled correctly with all steps following concisely, allowing the candidate to develop a prototype with accuracy. The candidate checked each stage for accuracy, and before moving onto subsequent stages with confidence.</p> <p>The candidate undertook the manufacture of the prototype. The selection of equipment was appropriate at each stage of the task. Each piece was used correctly and accurately for the different stages of the development of the prototype. Whilst in the development, the candidate regularly re-checked</p> |

| | |
|------|---|
| Task | Notes – <i>detailed, accurate and differentiating notes which identify areas of strength and weakness are necessary to distinguish between different qualities of performance and to facilitate accurate allocation of marks once all evidence has been submitted.</i> |
| | <p>equipment to confirm that it remained in working order. The use of larger items of equipment was undertaken well, with the use of guards demonstrated.</p> <p>The candidate demonstrated a high degree of accuracy when measuring consumables. Each component was measured accurately before cutting and was re-measured following cutting to ensure accuracy. This approach allowed the components to be assembled correctly without any rework required.</p> <p>The candidate demonstrated a range of skills in the construction of the prototype. The individual components were carefully and appropriately cut using the correct tools. Cutting was done to a high degree of accuracy.</p> <p>The assembly was accurate, with the final prototype being developed to reflect the original design specification and drawings. The candidate took care during the construction to ensure that all finishes were carefully considered. For instance, measurements were taken before and after soldering. The prototype was filed and sanded before carefully spraying to the desired colour.</p> <p>The arms were cut using a hacksaw and then were manipulated by a vice and using hammers to shape them according to the design and model. These were also measured for accuracy. The final product had the surface finished and all edges smoothed off to give an excellent appearance. Care was taken when aligning the members of the pylon so that they were aligned to centroids.</p> <p>The candidate made some coherent checks of the final assembled prototype, comparing the output to what had been initially intended and ensuring that it was fully functional. The candidate measured the prototype and confirmed it was accurately to scale. This was checked and was found to meet the intended parameters, with the prototype being less than 1 mm out of alignment on the arms of the mast, and with less than 1 mm gaps between the joints. This reflects a high degree of precision and accuracy in the construction of the prototype. The candidate secured and cleaned the work area and reset ready for testing.</p> <p>The candidate was conscientious at all times with regard to health and safety of themselves and those around them, wearing the correct PPE throughout. Tools and equipment were placed carefully out of the way after use, and the candidate ensured that used consumables and off-cuts were removed and disposed of carefully following correct workplace regulations. Prior to moving to the testing element, the candidate reset the work area – cleaning down and returning equipment. Equipment was checked prior to return. The candidate advised others in the workspace that they had finished the activity.</p> |

| | |
|---------------------------|-------------|
| Assessor signature | Date |
| <i>Assessor A</i> | 03/04/2022 |

Commentary

The candidate was observed undertaking the correct and accurate construction of the prototype. The candidate demonstrated a high degree of skill to effectively complete a finished prototype, that fully reflected the initial design solution proposed. The candidate performed the construction of the prototype with a high regard for health and safety. A range of pre-work checks were undertaken, that were followed by consistent consideration of health and safety throughout the construction of the prototype.

The candidate developed the prototype following a clear, logical and defined sequence. Work was checked after each stage to confirm accuracy and quality of finish, before moving to the next element of the task. This ensured the construction was effective and accurate, and meant that no rework or revisions were required throughout the construction.

The candidate demonstrated excellent use of hand skills when using tools and equipment, that was appropriately reflected in the finish of the prototype that was noted to be clear and clean, without any compromises in final quality. The final prototype was measured and found to be precise in its dimensions, with tolerances within 1 mm of the required parameters, reflecting the high quality of care and precision used in its construction.

2c) Testing

Candidate evidence

Tensile test results

| Loads (KN) | Strain readings (mm) | | Average strain reading | Average X 0.2% | Diameter (mm) | Stress (N/mm ²) |
|-----------------------|----------------------|-----|------------------------|----------------|---------------|-----------------------------|
| | LR | RR | | | | |
| 0 | 0 | 0 | 0 | 0 | 25.7 | 0 |
| 60 | 0.6 | 0.5 | 0.55 | 0.11 | 25.7 | 116.0 |
| 100 | 0.8 | 0.7 | 0.75 | 0.15 | 25.7 | 198.0 |
| 140 | 1.2 | 0.9 | 1.05 | 0.21 | 25.7 | 361.6 |
| 160 | 1.6 | 0.8 | 1.20 | 0.24 | 25.7 | 413.2 |
| 180 | 2.0 | 2.1 | 2.05 | 0.41 | 25.7 | 464.9 |
| 200 | 2.4 | 2.2 | 2.30 | 0.46 | 25.7 | 516.5 |
| AFTER YIELDING | | | | | | |
| 220 | | | | | 25.5 | 568.2 |
| 240 | | | | | 24.8 | 619.8 |
| 260 | | | | | 24.2 | 671.5 |
| 280 | | | | | 23.4 | 723.1 |

Results taken from the specimen Grade 355 steel as detailed in Bill of Materials.

- Initial diameter (d_0) of specimen was 25.7 mm
- Initial gauge length (L_0) of specimen was 128.5 mm

- Diameter at fracture (d_f) of the specimen was 19 mm
- Length at fracture (L_f) of the specimen was 201 mm

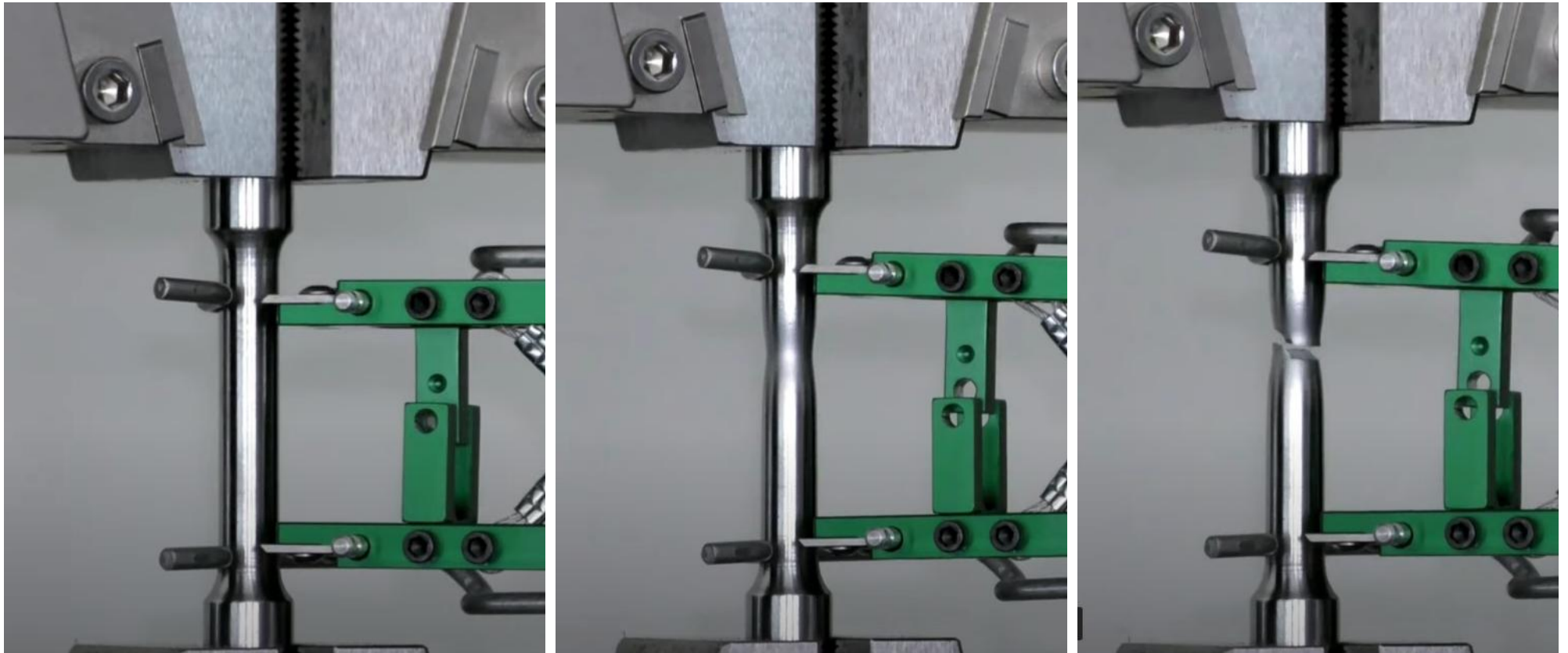

Photographs show the process used for the tensile testing with rod, threaded using a lathe to fit the machine. The left image shows the test piece in place with some force applied, the middle image shows 'necking' of the material and the right image shows that Young's modulus point has been met and the material has fractured.

Three Point Bending Test

Specimen span: 120 mm

Specimen dimension: 20 × 6 mm

Modulus of elasticity of the material: 200 kN/mm²

Position of neutral access: 60 × 10 × 3 mm

| Applied force (N) | Vertical strain (mm) | Experimental bending stress E (N/mm ²) | Theoretical bending stress (N/mm ²) | Percentage error |
|-------------------|--------------------------|--|---|------------------|
| 20 | 0.01 | 60 | 0.62 | +/- 0.1 |
| 40 | 0.03 | 120 | 1.20 | +/- 0.1 |
| 60 | 0.08 | 180 | 1.60 | +/- 0.5 |
| 100 | 0.11 | 240 | 2.35 | +/- 0.8 |
| 120 | 0.16 | 320 | 3 | +/- 1 |
| 140 | Young's Modulus exceeded | | | |
| 160 | | | | |

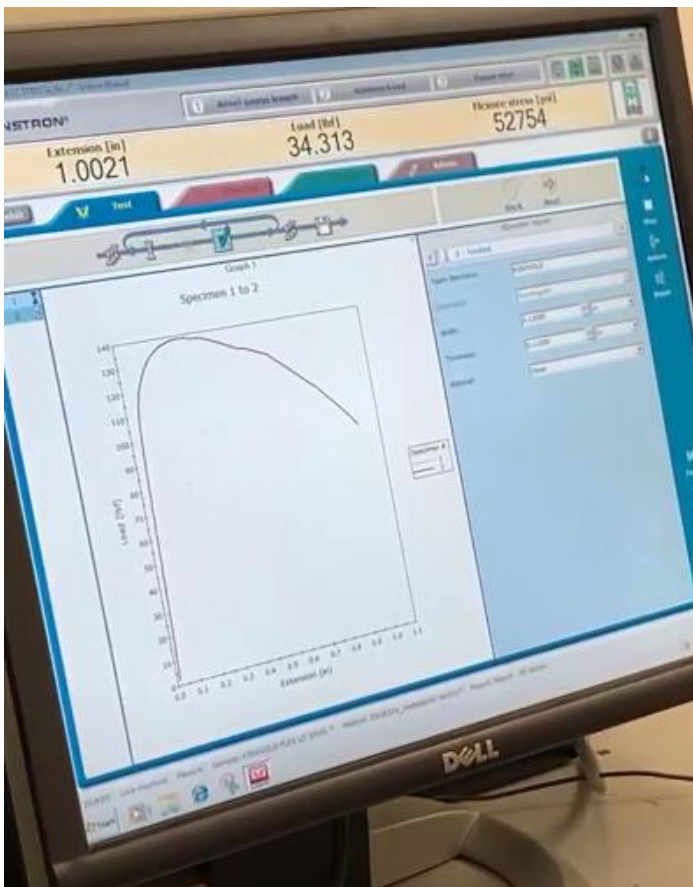

Photograph shows the results of the three-point bending test in a graph format, showing Young's modulus.

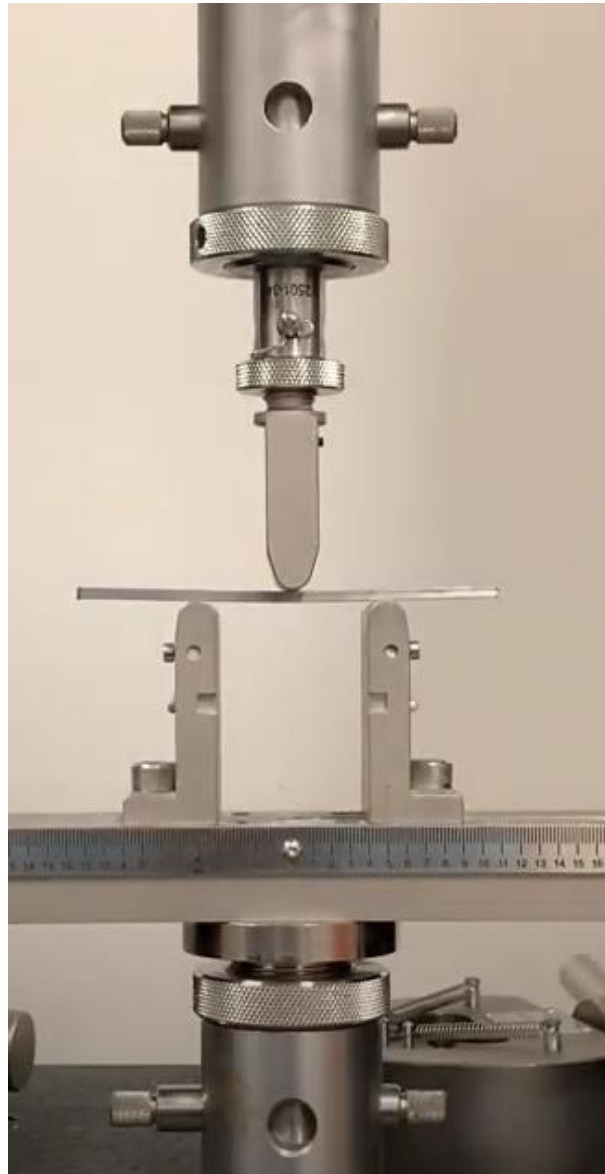

Photographs show the process used for the three point bending test on bar. The left image has the test piece in place, the middle image shows force being applied to the test piece and the right image shows the stress point has been met and the material has folded.

Practical observation form – Testing

| | |
|-----------------------|-----------------------------|
| Assessment ID | Qualification number |
| 8714-324 | 8714-34 |
| Candidate name | Candidate number |
| Candidate A | CG12345 |
| Centre name | Assessment theme |
| City & Guilds | Manufacturing Reports |

Complete the table below referring to the relevant marking grid, found in the assessment pack. **Do not** allocate marks at this stage.

| | |
|----------------|---|
| Task | Notes – <i>detailed, accurate and differentiating notes which identify areas of strength and weakness are necessary to distinguish between different qualities of performance and to facilitate accurate allocation of marks once all evidence has been submitted.</i> |
| Testing | <p>Following the development of the prototype, the candidate set the work area up in order to carry out testing. The candidate visually checked the work area to confirm that it was ready for testing. The risk assessment was revisited, and controls re-checked to confirm testing could be undertaken safely.</p> <p>The candidate ensured that they had access to the original design criteria and confirmed the requirements of the prototype prior to starting testing procedures.</p> <p>The candidate prepared to undertake tensile testing to confirm the tensile strength and the yield point at which the prototype necked and snapped under the exerted force. The testing equipment was checked for readiness, and the calibration reviewed to ensure it would produce an accurate result. The candidate operated the testing equipment correctly, noting the results of the test. The results were checked for accuracy, reviewed against the original design criteria and noted on the test record.</p> <p>The candidate prepared to undertake a three point bending test. A flexural testing machine was used for the test. The candidate checked the machine for readiness and confirmed the calibration to ensure it would produce an accurate result. The candidate operated the testing equipment correctly, noting the results of the test. The results were checked for accuracy, reviewed against the original design criteria and noted on the test record.</p> <p>When the testing had been completed, the candidate returned equipment correctly to its location in the workspace. A final check of the work area was made to ensure that it was ready for work by others.</p> |

| | |
|---------------------------|-------------|
| Assessor signature | Date |
| <i>Assessor A</i> | 03/04/2022 |

Commentary

The candidate successfully undertook thorough testing procedures using testing equipment to undertake tensile testing, and a bending test. Testing was undertaken accurately and following clear, logical process steps. They selected appropriate test methods and test equipment, using them with a high level of skill to produce results that were accurate, precise and repeatable.

The candidate ensured the integrity of the test by checking the readiness and calibration of the testing equipment prior to starting each test, ensuring the reliability of the result. The candidate revisited the risk assessment prior to commencing the testing activity and ensured that the equipment was used safely.

The candidate recorded their test results accurately in the test record sheets and interpreted the results against each of the original design criteria to ensure that they are all met.

Task 3 – Peer review

(Assessment themes: Reports)

For task 3, candidates must produce the following pieces of evidence:

- candidate notes on the candidate feedback record form

The candidate notes are not included in this document as the notes will vary from candidate to candidate and are not used to inform any other task.

- peer review feedback form.

This is supporting evidence for assessors to see what feedback the candidate received and how they used it in their review for task 4, and will not be marked.

Peer review feedback form

Candidate evidence

| | |
|-----------------------|-------------------------|
| Candidate name | Candidate number |
| Candidate B | CG01234 |
| Centre name | Centre number |
| City & Guilds | 12345 |

| Question | Feedback |
|--|--|
| Explain how well the diagrams/drawings meet the design criteria. | <i>The design meets the requirements of the brief, with the proposed pylon having the correct overall height and length of cross arms. They have chosen to galvanise the pylon and paint it light grey so aesthetically it will be acceptable in both the urban and rural environment. The galvanised finish will be resilient to all weather conditions. They have also included pictures of the pylon which is a good way to show people what the pylon will look like when evaluating the design and how well it will fit into the skyline.</i> |
| Explain how well the diagrams/drawings meet the specification criteria. | <i>The concept section sizes for the column mast and arms were marked on the sketches. These seem sensible for the anticipated imposed loading of 600kN. For a more efficient lightning protection system, the use of an air lightning rod and full strip covering the full length would provide a more effective solution. Finally, they have considered how the pylon will be delivered and welded together onsite.</i> |
| What are the implications for the proposed maintenance of the pylon? | <i>The proposed solution considers the external finishes to the pylon reducing the potential for corrosion during the operational life by galvanising the mast and cross arms prior to painting. The design of the pylon also utilises symmetry to help with craning operations during erection and removal at the end of life.</i> |
| How can the design be optimised/ improved? | <i>At present they have provided limited comments on how the pylon might be repurposed at the end of its life. The design would overall be improved with a some more comments on this point. They could also comment further on any other anticipated loading that might impact on the structure due to poor weather conditions e.g. wind loading.</i> |

Task 4 – Evaluation and implementation

(Assessment themes: Health and safety, Design and planning, Reports)

For task 4, candidates need to produce the following pieces of evidence:

- a) outcomes of virtual modelling
- b) revision control document
- c) evaluation and implementation report.

4a) Outcomes of virtual modelling

Candidate evidence

I applied Eurocode 1 EN 1991-1-4 and I considered the approach taken by lamp posts (Eurocode 3). From this research, I decided to taper my pylon's mast.

To do this I calculated the pylon into 4 sections at 9-meter lengths. The pylon is now tapered from constant $\text{Ø}457$ mast to a tapering mast, $\text{Ø}550$ at the bottom to $\text{Ø}457$ at the top, with increments of 23.25 per incremental stage.

From the peer feedback, I also realised that the lightning protection system could be improved, so I carried out some research and have discovered that an air lightning rod can be bolted to the top of the pylon.

With this fixture that is commonly used on similar high or lightning prone constructions, the fixing encompasses a copper lightning conductor strip. I will add this to the existing design to make for a more efficient lightning protection system. This conforms to IEC/BS EN 62305-3 and provides the requirements for the protection of a structure against physical damage, by means of a lightning protection system, and for protection against injury to living beings due to touch and step voltages, in the vicinity of a lightning protection system.

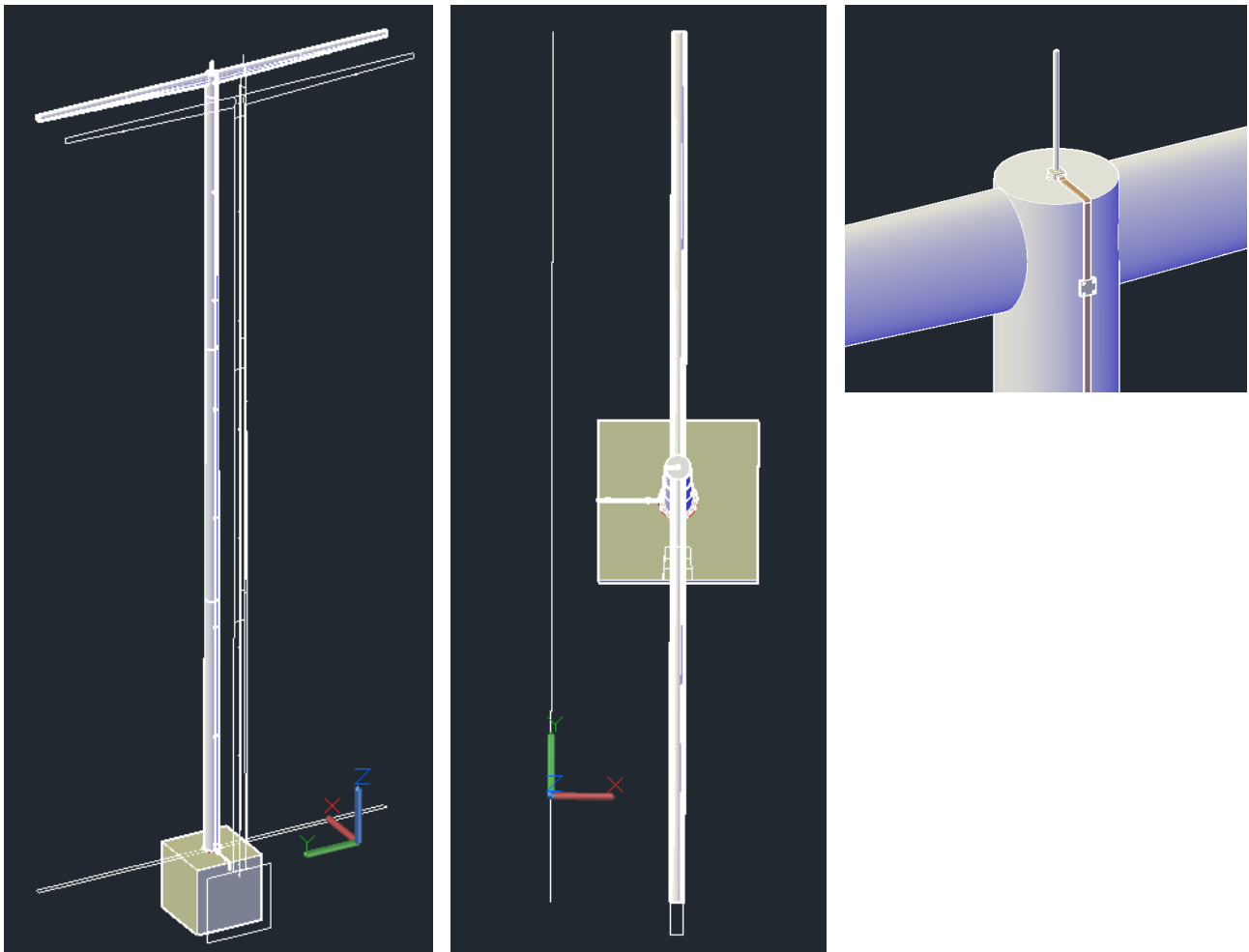

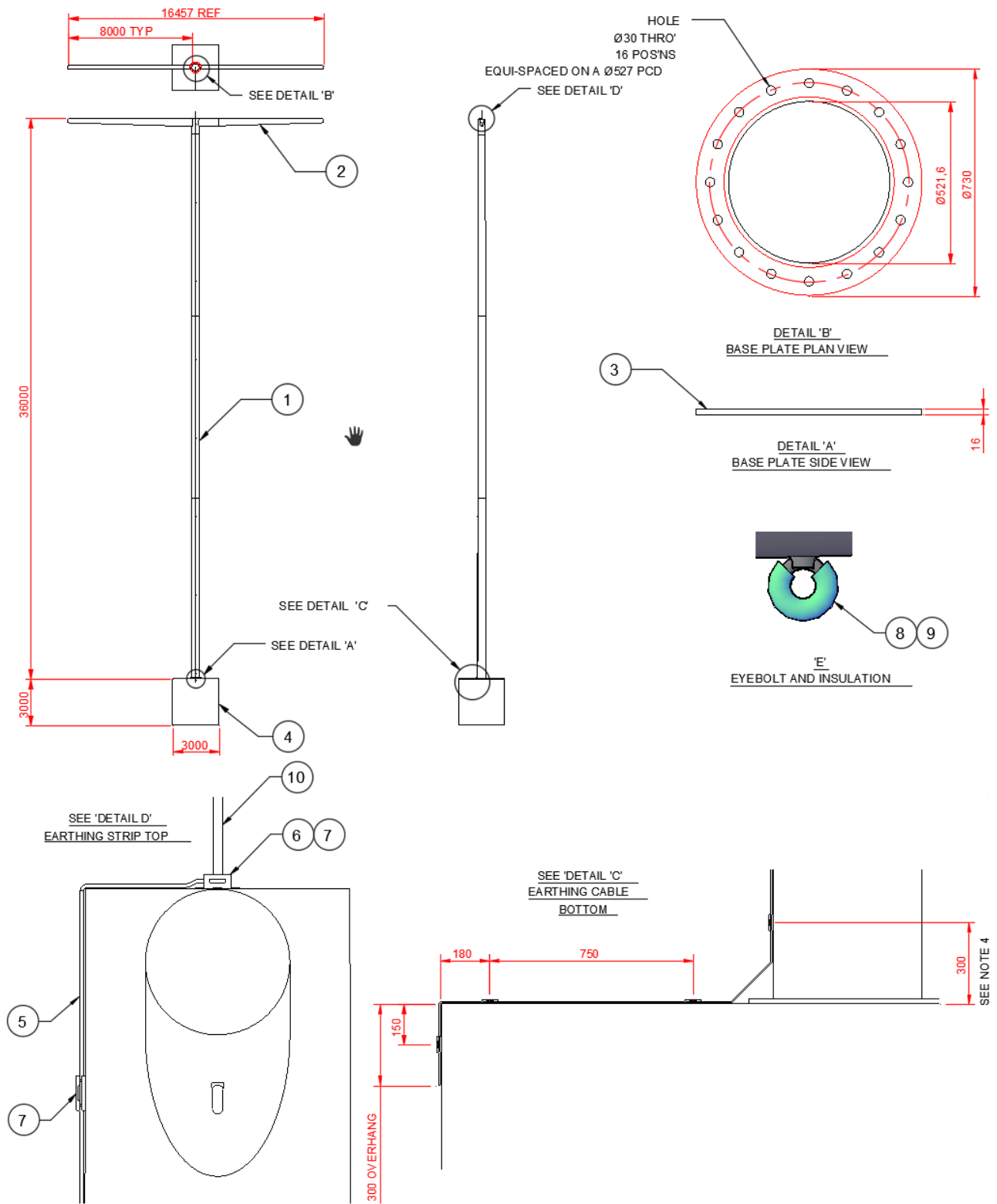

| PARTS LIST | | |
|------------|---------------|----------|
| BALLON No. | ITEM | QUANTITY |
| 1 | MAST | 1 |
| 2 | CROSS ARM | 2 |
| 3 | BASE PLATE | 1 |
| 4 | CONCRETE BASE | 1 |

| | | |
|----|---------------------|-----|
| 5 | EARTHING STRIP | 40M |
| 6 | EARTH TERMINAL BASE | 1 |
| 7 | CLAMP ASSEMBLY | 11 |
| 8 | EYEBOLT | 2 |
| 9 | INSULATION | 2 |
| 10 | AIR TERMINATING ROD | 1 |

NOTES:

- ALL DIMENSIONS ARE IN MM
- ITEM 1 - MAST: Ø550 TO Ø457 x 14.2 CHS
- ITEM 2 - CROSS ARM: (500 x 250 x 16) TO (Ø250 x 16) ELLIPTICAL TO CIRCULAR CROSS SECTION
- ITEM 6 TO BE POSITIONED AS SHOWN, THEN IN EQUAL SPACINGS OF 5050MM APART

Commentary

The candidate has researched the specifics of Eurocode 1 and applied these to the pylon. They carried out calculations and demonstrated the appropriate mathematics skills to accurately configure the tapering of the pylon (meeting the EN 1991 – 1-4). Scaling was implemented to match the design specifications. Each incremental point was accurately calculated. The candidate has undertaken appropriate research on lightning protection systems and the relevant regulations. They then made the relevant updates to their CAD design in order to create the virtual model with success.

The candidate has provided multiple angles and views of the updated 3D virtual model produced in CAD software, that demonstrate the tapering of the mast as well as a close up of the added lightning protection.

The candidate has also provided a detailed engineering drawing of the pylon based on the updated dimensions of the mast, which includes fixings (bolts and washers) at the connection points of the lightning protection system. The lightning protection system has been further developed by adding an air lightning terminating rod to the top of the pylon.

4b) Revision control document

| | |
|---|-----------------------------------|
| System type | Development of a new pylon |
| System TAG number | PYLON0001 |
| Department responsible for equipment | Design and Development department |
| | |
| System designed by: | Candidate A |

Design description:

The design specification and drawings reflect the development of a new pylon. A prototype has been developed based on original design criteria.

Changes to current design:

The peer review noted only a couple of suggestions for how I might improve my design. I need to give further consideration to how I might use the pylon at the end of its life. I think this is an interesting suggestion as I suspect that the pylon will in fact be required to last beyond its anticipated design life of 50 years and will in reality have an extended service life. The extension to the pylon's life might be achieved by repainting it and replacing wiring components such as the suspended insulator strings or overhead lines. The strip in lightning protection system is made out of copper and brass, which are excellent conducting materials. They are also highly recyclable which adds to the sustainability of the design.

To maximise the life of the pylon, I proposed to manufacture the unit initially from galvanised steel. Galvanising involves cleaning the steel and immersing it in molten zinc at a temperature of 450°C to gain a coating. Galvanised steel can be recycled easily using an electric arc furnace as part of a steel production process. The zinc coating volatises early in this process and is collected as dust which can then be recycled separately as part of refined zinc production.

Part of the peer review also asked me to consider how I can make the pylon robust against the impact of loading arising as a result of poor weather conditions. Such loading is most likely to be applied by the wind. I will consider a horizontal wind load on the side of the pylon. I can get an idea of how big this wind load needs to be by considering the design standards Eurocode 1.

The wind loading will be influenced by the altitude of the pylon above sea level, and the nature of the surrounding environment. If the pylon is located in the countryside, it might be exposed to long gusts of wind, or alternatively if the pylon is located in the urban landscape then it might experience funnelling affects between buildings.

The peer review mentioned the efficiency of the existing lightning protection system. I did some research and decided to implement the changes using existing products available on the market, in order to conform to the IEC/BS EN 62305-3 I.

Validation performed by:

Assessor 1

Prototype approved by:

Assessor 1

Date:

16/06/2022

Commentary

The candidate has produced a detail revision control document, which demonstrates that they have understood the peer feedback they received and have considered how to implement it. They have produced appropriate responses to the main considerations given in the peer feedback.

The candidate has structured their response to reflect what the required changes are, and that these would need to be incorporated and reflected in the appropriate technical documentation.

The document includes specific detail on the changes the candidate is considering, for example considering how they can achieve longer service of the pylon by repainting it and replacing wiring components. They have also demonstrated thorough knowledge of material properties through their comments on galvanisation process and zinc coating.

4c) Evaluation and implementation report

Candidate evidence

| | |
|-----------------------|--|
| Evaluation | <p>Upon review of the design and consideration of peer review feedback, it is agreed that the design meets the criteria required in the specification.</p> <p>The prototype has been subjected to simple scale testing for structural loading. As the pylon is subject to largely static loading, this should be acceptable, but it would still be prudent to prepare and install a full-size prototype pylon at a test site as the next step. This will enable the finalisation of testing for both for structural loading and for the suitability of material finishes. For example, the construction of a full-scale prototype will enable the visual impact of the pylon on the skyline to be confirmed. Some of the peer review feedback was related to loading; as part of the large-scale load testing, it would be appropriate to consider accidental impact and wind loading on the pylon. Any wind loading will be applied to the pylon structure in the horizontal direction, with the overall pylon mast and arms acting like a cantilever.</p> <p>The feedback received during peer review includes comments on the sustainable repurposing of the pylon at the end of its design life. Although, it is likely that the service life of the pylon will be extended past the planned life with appropriate routine maintenance, it is necessary to plan for disposal. Under the CDM Regulations 2015 a Health and Safety file will be prepared for any large-scale pylon installation project. This file will contain the fabrication and erection details for the pylon and information concerning site specific services. This file will be passed on to the engineers maintaining and disposing of the pylon at the end of its life. As the pylon is produced from galvanised steel it can be recycled using an electric arc furnace.</p> |
| Implementation | <p>Initially before installing the pylon, the parts including the selected lightning protection and equipment will need to be purchased and fabricated. The main body and cross arms of the pylon are made from structural steel and steel fabrication will be required. A full inventory of each section of steel will be needed including the overall dimension and thicknesses. It will also be necessary to communicate the size and position of any required welds. To do this it is normal to prepare a schedule of the safe working load the pylon has been designed to accommodate.</p> <p>Each pylon will be installed at a unique location either in the countryside or in an urban setting. On a site-by-site basis it will also be necessary to determine information relating to ground conditions and services, so that the final details of the foundations can be prepared. The foundations for the pylon will be designed to accommodate the ground bearing capacity at each site which will be determined by geotechnical investigation. The team installing the pylon will also need to check service records and find utility services on site so that they don't impact on any existing supplies e.g. gas mains.</p> <p>The pylon will be installed using a mobile crane and it might be necessary to construct a new access road, so that the pylon can reach the installation site.</p> <p>Once all the components have been installed and the pylon has been erected, the high voltage catenary wires can be added, and the system will be energised with functional testing. Once testing is complete, the system can be officially signed off as commissioned and will become subject to regular maintenance.</p> |

Commentary

The evaluation report provided identifies a range of relevant improvements that could be made to the design, with detailed reasoning and justifications, such as the positive impact on batch production targets for the company. The candidate demonstrates broader understanding of business practices and implications of a successful design.

The candidate has demonstrated an awareness that the development of a prototype has limitations in reflecting the final product. Their evaluation provides detail on the degree to which they feel the prototype is still an effective representation of the final product, for example the subject of stresses reflected through the testing undertaken.

The implementation report provided discusses potential modifications and installation requirements, clearly separated into stages which demonstrate clear understanding of the process required. The candidate has demonstrated an awareness of the different installation requirements needed, with broad consideration given to the local environment, the process to install and the specific design criteria of the pylon.

Copyright in this document belongs to, and is used under licence from the Department for Education, © 2022 - 2026.

'T-LEVELS' and 'T Level' are registered trade marks of the Department for Education.

© City & Guilds Limited is authorised by the Department for Education to develop and deliver this T Level Technical Qualification.

City & Guilds is a registered trade mark of © City & Guilds Limited.