



City & Guilds Level 3 End-point Assessment for Engineering Maintenance Technician (Dual Discipline) (9331-12)

**303 Electrical and Control and Instrumentation
Engineering Maintenance Technician**

Standard: ST1443, EPA Plan: Version 1.0

QN: 610/6878/0

Version 1.0

Last modified: June 2026

**Sample Knowledge Test
Sample paper, multiple-choice answer sheet and
mark scheme**

Version	Summary of changes	Section
1.0 June 2026	Document created	N/A

1	Introduction	4
2	9331-303 End-point Assessment – multiple-choice test (sample questions)	5
3	9331-303 End-point Assessment – multiple-choice knowledge test (answer sheet)	29
4	9331-303 End-point Assessment – multiple-choice knowledge test (mark scheme)	32

1 Introduction

Area	Description
What is in this document	This document contains the sample test, answer sheet and mark scheme for the 9331-12 Engineering Maintenance Technician (Dual Discipline) Multiple-choice Test (303 Electrical and control and instrumentation).
Documents included:	<ul style="list-style-type: none">• Sample questions• Answer sheet• Mark scheme <p>Apprentices should be provided with the sample questions and the answer sheets.</p> <p>The mark scheme is to be used by employers/training providers/tutors to mark the completed test.</p>

Note to employers/training providers/tutors: this sample paper-based version of the multiple-choice test is to support formative assessment activities.

Live versions of the multiple-choice test will be accessed using City & Guilds e-evolve online system. Please refer to the EPA handbook for details on how to book and administer live tests.

2 9331-303 End-point Assessment – multiple-choice test (sample questions)

Test duration: 75 minutes

You should have the following for this test:

- a pen with black or blue ink
- multiple-choice questions answer sheet.

Read the following notes before you answer any questions.

- Attempt all questions.
- If you find a question difficult, leave it and return to it later.

This paper contains 50 multiple-choice questions worth 1 mark each.

This test paper is the property of City & Guilds.

How to complete the multiple-choice answer sheet

Each multiple-choice question shows four possible answers (lettered 'a', 'b', 'c', 'd'); only one is correct.

Decide which one is correct and mark your answer on the answer sheet with your pen.

For example, if you decide 'b' is correct, mark your answer with a cross like this:

1 a b c d

If you change your answer, cancel your first choice by filling in the box then put a cross in the answer which you have now decided is correct, like this:

1 a b c d

	<p>a) DSE.</p> <p>b) PPE.</p> <p>c) COSHH.</p> <p>d) COMAH.</p>
Spec reference	8.1.4 (b)

Q6	<p>According to RIDDOR, how many consecutive days must an injury stop a worker from doing their usual job for before it must be reported to the HSE?</p> <p style="text-align: right;">(1 mark)</p>
	<p>a) More than 2 days.</p> <p>b) More than 3 days.</p> <p>c) More than 5 days.</p> <p>d) More than 7 days.</p>
Spec reference	8.2.5 (a)

Q7	<p>An engineer is employed by a maintenance engineering company. According to the PPE Regulations, what is a responsibility of the engineer prior to completing a maintenance activity?</p> <p style="text-align: right;">(1 mark)</p>
	<p>a) To alter the condition of PPE for the activity.</p> <p>b) To complete a risk assessment to determine the PPE for the activity.</p> <p>c) To inspect PPE for any damage before using it in the activity.</p> <p>d) To provide PPE to other employees who are completing the activity.</p>

Spec reference	8.2.7 (a) (ii)
-----------------------	----------------

Q8	Which standard gives the requirements for an Environmental Management System? (1 mark)
	<ul style="list-style-type: none"> a) BS 7671 b) BS 8888 c) ISO 9001 d) ISO 14001
Spec reference	K13.1.1 (a)

Q9	<p>A minor spill has occurred that poses no immediate danger.</p> <p>What should be the first action according to spill-response procedures?</p> <p>(1mark)</p>
	<ul style="list-style-type: none"> a) Attempt to contain the spillage. b) Evacuate the area affected. c) Clean the area affected. d) Document the incident.
Spec reference	K13.2.1 (d)

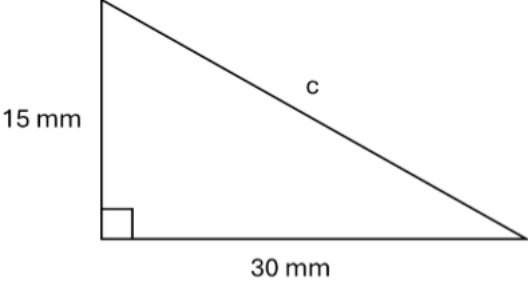
Q10	<p>The support bracket below forms a right angle. What is the length of side c to the nearest whole number?</p>  <p>15 mm</p> <p>30 mm</p> <p>c</p> <p>Not to scale</p> <p>(1 mark)</p>
	<p>a) 28 mm</p> <p>b) 34 mm</p> <p>c) 40 mm</p> <p>d) 45 mm</p>
Spec reference	17.1.1 (e)

Q13	<p>What does contact between two incompatible metals in the presence of an electrolyte result in?</p> <p style="text-align: right;">(1 mark)</p>
	<p>a) Corrosion of both metals at the same speed.</p> <p>b) Faster corrosion of the more active metal.</p> <p>c) Faster corrosion of the less active metal.</p> <p>d) No corrosion of either of the two metals.</p>
Spec reference	18.2.1 (d)

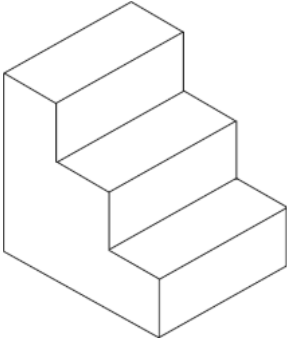
Q14	<p>What type of engineering representation format is shown below?</p> <div style="text-align: center;">  </div> <p style="text-align: right;">(1 mark)</p>
	<p>a) Detail.</p> <p>b) Assembly.</p> <p>c) Isometric.</p> <p>d) Orthographic.</p>
Spec reference	21.1.1 (d)

Q15	<p>What does this symbol represent on an electrical circuit diagram?</p> <div style="text-align: center;">  </div> <p style="text-align: right;">(1 mark)</p>
	<p>a) Lamp.</p> <p>b) Resistor.</p> <p>c) Signal diode.</p> <p>d) Light emitting diode.</p>
Spec reference	21.2.1 (c)

Q16	<p>Which best describes the application of the Internet of Things (IoT) in maintenance?</p> <p style="text-align: right;">(1 mark)</p>
	<p>a) Connected sensors that share data in real time.</p> <p>b) Remote access to data via cloud files sharing services.</p> <p>c) Use of physical equipment integrated with digital control.</p> <p>d) Use of pre-programmed robots to perform system repairs.</p>
Spec reference	32.1.1 (b)

Q17	Which technology can be used to analyse data trends to support predictive maintenance? (1 mark)
	<ul style="list-style-type: none"> a) IoT. b) AI. c) HMI. d) PLC.
Spec reference	32.2.1 (d)

Q18	What is the role of digital twins in maintenance? (1 mark)
	<ul style="list-style-type: none"> a) To use virtual models to design brand new products from scratch. b) To use physical models of digital systems to simulate their performance. c) To use virtual models of physical systems to simulate their performance. d) To use virtual models to simulate system components that are not physically possible to make.
Spec reference	32.3.1 (c)

Q19	<p>A maintenance engineer has been asked to replace a faulty power supply for a DC motor. The motor has a resistance of 50Ω and draws a current of 0.24 A when in use.</p> <p>What voltage power supply should be used for the DC motor?</p> <p style="text-align: right;">(1 mark)</p>
	<p>a) 0.005 V</p> <p>b) 12 V</p> <p>c) 50.2 V</p> <p>d) 208 V</p>
Spec reference	S13.1.1 (a) (i)

Q20	<p>A maintenance engineer is tightening a bolt as part of re-assembling a machine. They are using a wrench that is 0.2 metres in length. The engineer applies a force of 90 N at a right angle to the end of the wrench handle.</p> <p>What is the amount of torque applied to the bolt?</p> <p style="text-align: right;">(1 mark)</p>
	<p>a) 450 Nm</p> <p>b) 90.2 Nm</p> <p>c) 18 Nm</p> <p>d) 0.002 Nm</p>
Spec reference	S13.1.1 (a) (iii)

Q21	<p>What is the employee's primary responsibility when working on electrical equipment?</p> <p style="text-align: right;">(1 mark)</p>
	<p>a) Follow the employer's safety procedures and processes.</p> <p>b) Follow your own safety procedures and processes.</p> <p>c) Follow industry safety procedures and processes.</p> <p>d) Follow the manufacturer's safety procedures and processes.</p>
Spec reference	33.1.2 (a)

Q22	<p>Which statement best defines the relationship between BS 7671 and Electricity at Work Regulations (EAWR)?</p> <p style="text-align: right;">(1 mark)</p>
	<p>a) BS 7671 is statutory law and EAWR is a supporting code of practice.</p> <p>b) EAWR and BS 7671 are legal acts of parliament that must be followed by law.</p> <p>c) BS 7671 provides technical standards that support compliance with EAWR.</p> <p>d) BS 7671 sets out employer responsibilities for electrical safety training under EAWR.</p>
Spec reference	33.3.1 (a)

Q23	What is the main purpose of a Permit to Work document? <p style="text-align: right;">(1 mark)</p>
	<p>a) To provide basic safety guidance for employees who have not received any formal training.</p> <p>b) To authorise and control high risk work and ensure safety measures are in place.</p> <p>c) To increase operational efficiency by removing the need for routine safety checks.</p> <p>d) To ensure employees are provided with guidance on what to do when accidents occur.</p>
Spec reference	33.4.2 (b)

Q24	Which is the correct industrial application of a single-phase circuit? (1 mark)
	<p>a) Powering heavy industrial welding equipment.</p> <p>b) Powering manufacturing production lines.</p> <p>c) Powering large CNC machines.</p> <p>d) Powering portable power tools.</p>
Spec reference	35.1.1b

Q32	What is a function of a distribution board in an industrial facility?
	<ul style="list-style-type: none"> a) To provide backup power supply to industrial plant in the event of main power failure. b) It divides main power feed into subsidiary circuits and provides protective disconnection. c) To monitor the consumption of supplied electricity within an industrial circuit. d) It acts as an isolation device to protect equipment during testing only.
Spec ref	37.2.1 (a)

Q33	<p>Which electrical component does this circuit symbol represent?</p>  <p style="text-align: right;">(1 mark)</p>
	<ul style="list-style-type: none"> a) Battery. b) Lamp. c) Resistor. d) Transformer.
Spec reference	38.2.2 (a) (iii)

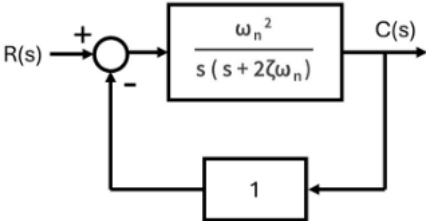
Q44	<p>What type of control system is this?</p>  <p style="text-align: right;">(1 mark)</p>
	<p>a) First order system.</p> <p>b) Second order system.</p> <p>c) Open-loop system.</p> <p>d) Non-feedback system.</p>
Spec reference	50.2.1 (a)

Q45	<p>What is the function of the Integral term within a three-term controller?</p> <p style="text-align: right;">(1 mark)</p>
	<p>a) To create new errors.</p> <p>b) To predict future errors.</p> <p>c) To respond to the current error.</p> <p>d) To eliminate steady state errors.</p>
Spec reference	50.3.1 (a) (iii)

Q46	<p>Which method of programming mimics relay circuitry?</p> <p style="text-align: right;">(1 mark)</p>
	<p>a) Text-based.</p> <p>b) Flow charts.</p> <p>c) Ladder logic.</p> <p>d) Function blocks.</p>

Spec reference	51.1.1 (c) (i)
-----------------------	----------------

Q47	Which is the most typical application of a Direct Digital Control (DDC) system? (1 mark)
	<ul style="list-style-type: none"> a) Small-scale automation. b) High-speed industrial automation. c) Large building HVAC automation. d) Safety-critical industrial process automation.
Spec reference	51.1.2 (b) (ii)

Q48	Which cybersecurity mitigation strategy scrambles readable data into unreadable code using a key? (1 mark)
	<ul style="list-style-type: none"> a) Firewall. b) Antivirus. c) Passwords. d) Encryption.
Spec reference	51.3.1 (b) (iv)

Q49	What type of diagram shows a high-level representation of groups of system components, with arrows representing signal flow between them? (1 mark)
	<ul style="list-style-type: none"> a) Block diagram. b) Circuit diagram. c) Wiring diagram. d) Schematic diagram.

Spec reference	52.1.1 (c) (i)
-----------------------	----------------

Q50	What does a solid thick line represent on an engineering drawing? <p style="text-align: right;">(1 mark)</p>
	a) Visible outline. b) Hidden outline. c) Centre line. d) Leader line.
Spec reference	52.1.4 (b) (i)

3 9331-303 End-point Assessment – multiple-choice knowledge test (answer sheet)

Candidate name:

Date of test: [Click or tap to enter a date.](#)

1	a <input type="checkbox"/>	b <input type="checkbox"/>	c <input type="checkbox"/>	d <input type="checkbox"/>
2	a <input type="checkbox"/>	b <input type="checkbox"/>	c <input type="checkbox"/>	d <input type="checkbox"/>
3	a <input type="checkbox"/>	b <input type="checkbox"/>	c <input type="checkbox"/>	d <input type="checkbox"/>
4	a <input type="checkbox"/>	b <input type="checkbox"/>	c <input type="checkbox"/>	d <input type="checkbox"/>
5	a <input type="checkbox"/>	b <input type="checkbox"/>	c <input type="checkbox"/>	d <input type="checkbox"/>
6	a <input type="checkbox"/>	b <input type="checkbox"/>	c <input type="checkbox"/>	d <input type="checkbox"/>
7	a <input type="checkbox"/>	b <input type="checkbox"/>	c <input type="checkbox"/>	d <input type="checkbox"/>
8	a <input type="checkbox"/>	b <input type="checkbox"/>	c <input type="checkbox"/>	d <input type="checkbox"/>
9	a <input type="checkbox"/>	b <input type="checkbox"/>	c <input type="checkbox"/>	d <input type="checkbox"/>
10	a <input type="checkbox"/>	b <input type="checkbox"/>	c <input type="checkbox"/>	d <input type="checkbox"/>
11	a <input type="checkbox"/>	b <input type="checkbox"/>	c <input type="checkbox"/>	d <input type="checkbox"/>
12	a <input type="checkbox"/>	b <input type="checkbox"/>	c <input type="checkbox"/>	d <input type="checkbox"/>
13	a <input type="checkbox"/>	b <input type="checkbox"/>	c <input type="checkbox"/>	d <input type="checkbox"/>
14	a <input type="checkbox"/>	b <input type="checkbox"/>	c <input type="checkbox"/>	d <input type="checkbox"/>
15	a <input type="checkbox"/>	b <input type="checkbox"/>	c <input type="checkbox"/>	d <input type="checkbox"/>
16	a <input type="checkbox"/>	b <input type="checkbox"/>	c <input type="checkbox"/>	d <input type="checkbox"/>
17	a <input type="checkbox"/>	b <input type="checkbox"/>	c <input type="checkbox"/>	d <input type="checkbox"/>
18	a <input type="checkbox"/>	b <input type="checkbox"/>	c <input type="checkbox"/>	d <input type="checkbox"/>
19	a <input type="checkbox"/>	b <input type="checkbox"/>	c <input type="checkbox"/>	d <input type="checkbox"/>
20	a <input type="checkbox"/>	b <input type="checkbox"/>	c <input type="checkbox"/>	d <input type="checkbox"/>
21	a <input type="checkbox"/>	b <input type="checkbox"/>	c <input type="checkbox"/>	d <input type="checkbox"/>
22	a <input type="checkbox"/>	b <input type="checkbox"/>	c <input type="checkbox"/>	d <input type="checkbox"/>

23	a <input type="checkbox"/>	b <input type="checkbox"/>	c <input type="checkbox"/>	d <input type="checkbox"/>
24	a <input type="checkbox"/>	b <input type="checkbox"/>	c <input type="checkbox"/>	d <input type="checkbox"/>
25	a <input type="checkbox"/>	b <input type="checkbox"/>	c <input type="checkbox"/>	d <input type="checkbox"/>
26	a <input type="checkbox"/>	b <input type="checkbox"/>	c <input type="checkbox"/>	d <input type="checkbox"/>
27	a <input type="checkbox"/>	b <input type="checkbox"/>	c <input type="checkbox"/>	d <input type="checkbox"/>
28	a <input type="checkbox"/>	b <input type="checkbox"/>	c <input type="checkbox"/>	d <input type="checkbox"/>
29	a <input type="checkbox"/>	b <input type="checkbox"/>	c <input type="checkbox"/>	d <input type="checkbox"/>
30	a <input type="checkbox"/>	b <input type="checkbox"/>	c <input type="checkbox"/>	d <input type="checkbox"/>
31	a <input type="checkbox"/>	b <input type="checkbox"/>	c <input type="checkbox"/>	d <input type="checkbox"/>
32	a <input type="checkbox"/>	b <input type="checkbox"/>	c <input type="checkbox"/>	d <input type="checkbox"/>
33	a <input type="checkbox"/>	b <input type="checkbox"/>	c <input type="checkbox"/>	d <input type="checkbox"/>
34	a <input type="checkbox"/>	b <input type="checkbox"/>	c <input type="checkbox"/>	d <input type="checkbox"/>
35	a <input type="checkbox"/>	b <input type="checkbox"/>	c <input type="checkbox"/>	d <input type="checkbox"/>
36	a <input type="checkbox"/>	b <input type="checkbox"/>	c <input type="checkbox"/>	d <input type="checkbox"/>
37	a <input type="checkbox"/>	b <input type="checkbox"/>	c <input type="checkbox"/>	d <input type="checkbox"/>
38	a <input type="checkbox"/>	b <input type="checkbox"/>	c <input type="checkbox"/>	d <input type="checkbox"/>
39	a <input type="checkbox"/>	b <input type="checkbox"/>	c <input type="checkbox"/>	d <input type="checkbox"/>
40	a <input type="checkbox"/>	b <input type="checkbox"/>	c <input type="checkbox"/>	d <input type="checkbox"/>
41	a <input type="checkbox"/>	b <input type="checkbox"/>	c <input type="checkbox"/>	d <input type="checkbox"/>
42	a <input type="checkbox"/>	b <input type="checkbox"/>	c <input type="checkbox"/>	d <input type="checkbox"/>
43	a <input type="checkbox"/>	b <input type="checkbox"/>	c <input type="checkbox"/>	d <input type="checkbox"/>
44	a <input type="checkbox"/>	b <input type="checkbox"/>	c <input type="checkbox"/>	d <input type="checkbox"/>
45	a <input type="checkbox"/>	b <input type="checkbox"/>	c <input type="checkbox"/>	d <input type="checkbox"/>
46	a <input type="checkbox"/>	b <input type="checkbox"/>	c <input type="checkbox"/>	d <input type="checkbox"/>
47	a <input type="checkbox"/>	b <input type="checkbox"/>	c <input type="checkbox"/>	d <input type="checkbox"/>
48	a <input type="checkbox"/>	b <input type="checkbox"/>	c <input type="checkbox"/>	d <input type="checkbox"/>
49	a <input type="checkbox"/>	b <input type="checkbox"/>	c <input type="checkbox"/>	d <input type="checkbox"/>
50	a <input type="checkbox"/>	b <input type="checkbox"/>	c <input type="checkbox"/>	d <input type="checkbox"/>



Number of correct answers: / 50

4 9331-303 End-point Assessment – multiple-choice knowledge test (mark scheme)

Grading

Fail – 34 marks (68%)

Pass – 35 marks (70%)

Question number	Key	Question number	Key
1	C	26	C
2	D	27	D
3	D	28	B
4	B	29	B
5	A	30	A
6	D	31	B
7	C	32	B
8	D	33	A
9	A	34	B
10	B	35	A
11	C	36	D
12	A	37	D
13	B	38	D
14	C	39	B
15	A	40	A
16	A	41	D
17	B	42	A
18	C	43	B
19	B	44	C
20	C	45	B
21	A	46	D

Question number	Key	Question number	Key
22	C	47	C
23	B	48	C
24	D	49	D
25	A	50	A

Who we are

City & Guilds Limited (Registered Company 16513878) is the Awarding Organisation for City & Guilds qualifications.

About City & Guilds

City & Guilds is the global skills partner, empowering people, organisations and economies to develop the skills they need for growth. With almost 150 years of trusted expertise, we support people into work, help them develop on the job and move into the next job.

We work with Governments, employers, training providers, colleges and industry stakeholders to design and deliver high-quality training, qualifications, assessments and credentials that lead to meaningful career progression. We understand the life changing link between skills development, social mobility and success. Our solutions span critical sectors including construction, engineering, transport, energy and electrical, serving over 1 million learners annually.

Through our comprehensive portfolio of brands and trusted global network, we set industry-wide standards for technical, behavioural and commercial skills to improve performance and productivity. We believe you can achieve your potential - and we're here to help make it happen.

City & Guilds

5-6 Giltspur Street
London EC1A 9DE
www.cityandguilds.com

Every effort has been made to ensure that the information contained in this publication is true and correct at time of publication. However, City & Guilds products and services are subject to continuous development and improvement, and the right is reserved to change products and services from time to time. City & Guilds cannot accept responsibility for any loss or damage arising from the use of information in this publication.

©2025 City & Guilds Limited (Reg No 16513878). All rights reserved. City & Guilds is a trademark of City & Guilds Limited.