

Functional Skills Mathematics Entry 2 Sample assessment

Candidate's paper - Non-calculator

Holidays

Marks: 9

Name: _____

City & Guilds Enrolment Number: _____

Date: _____

Start time: _____

Finish time: _____

You will need

- a pen with black or blue ink
- a pencil
- a rubber
- a ruler.

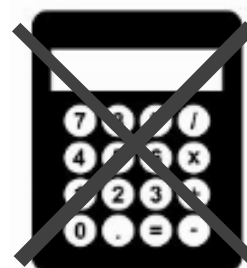

You must **not** use a calculator.

Instructions

- Read each question carefully.
- Answer **all** the questions.

Draft materials
Subject to Technical Evaluation by Ofqual.

Non-calculator paper

There are **9** marks available.

You must **not** use a calculator.



DRAFT

Q1. What number comes next in this list?

50 52 54 56

1 mark

Q2. Work out $67 \div 9 =$

Include the remainder with your answer.

1 mark

.....

Q3. Work out $73 - 28 =$

1 mark

.....

Q4.

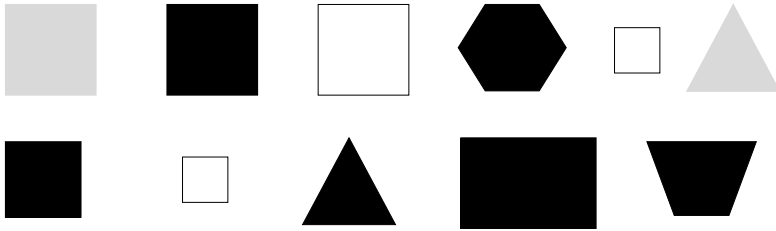

1 mark

Tick all the **white squares**.

Q5.

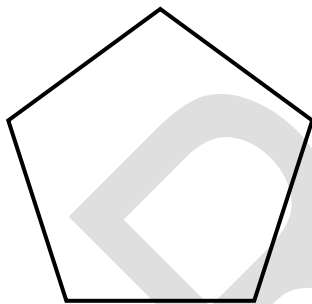

What is the name of this shape?

1 mark

.....

Q6. Count these crosses.

X X X X X X X X X X

X X X X X X X X X X

X X X X X X X X X X

X X X X X X

How many crosses (X) are there?

1 mark

.....

DRAFT

Q7. This bar chart shows the number of flights from an airport last week.

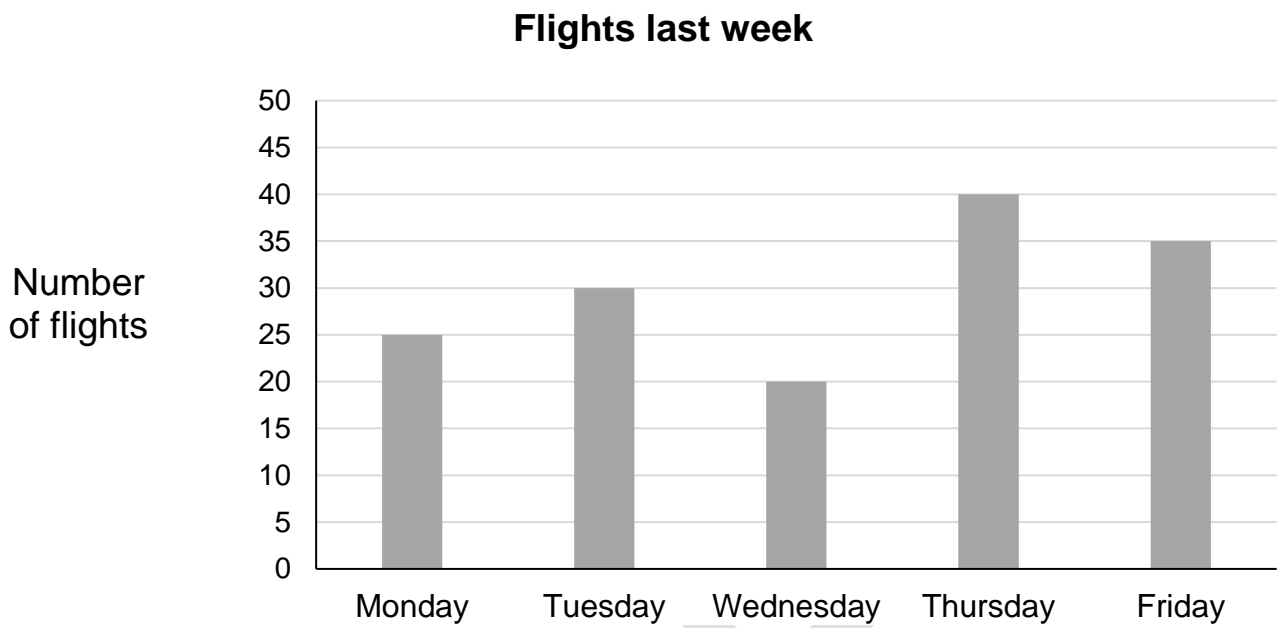

Which day had the biggest number of flights?

.....

1 mark

Q8. A passenger wants to take these things on a plane.



Tick all of the things that are **less than 100 ml**.

1 mark

DRAFT

Q9. A man lives 10 kilometres from work.

He works 4.5 kilometres from the airport.

He drives from his house to work. Then he drives to the airport.

How far does the man drive **in total**?

..... kilometres

1 mark

Total marks: 9

End of non-calculator paper

Functional Skills Mathematics Entry 2 sample assessment

Candidate's paper – Calculator allowed

Holidays

Marks: 27

Name: _____

City & Guilds Enrolment Number: _____

Date: _____

Start time: _____

Finish time: _____

You will need

- a pen with black or blue ink
- a pencil
- a rubber
- a ruler.

You must **not** use a calculator.

Instructions

- Read each question carefully.
- Answer **all** the questions.

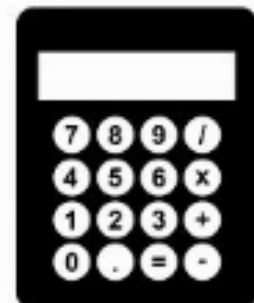

Draft materials
Subject to Technical Evaluation by Ofqual.

Calculator paper

There are **27** marks available.

You may use a calculator.

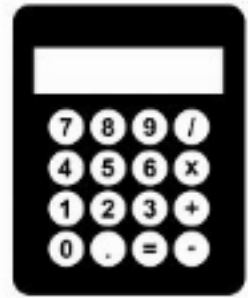

DRAFT

Q1. How many hours are in one day?

1 mark

.....

Q2.

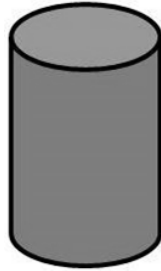

How many faces does a cylinder have?

- A. 2
- B. 3
- C. 4
- D. 6

1 mark

Q3. Colour in $\frac{1}{10}$ of the shape below.

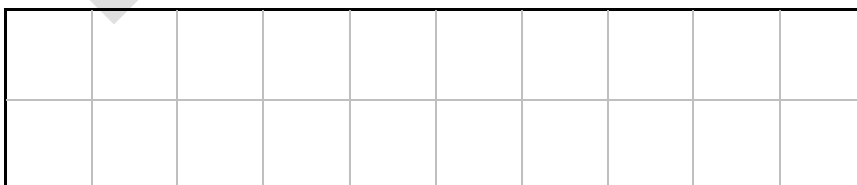

1 mark

Q4. The weather forecast for the **UK** next week is **21 °C** every day.

Here is the weather forecast for Spain next week.

Weather forecast for Spain						
Monday	Tuesday	Wednesday	Thursday	Friday	Saturday	Sunday
23°C	22°C	19°C	20°C	24°C	26°C	25°C

a. Which days will be warmer in Spain than in the UK? Tick all those days.

2 marks

b. The warmest day in Spain will be on

.....
1 mark

c. The coldest day in Spain will be on

.....
1 mark

d. Look at the chart. It needs two bars.

Draw **two** bars to finish the bar chart.

2 marks

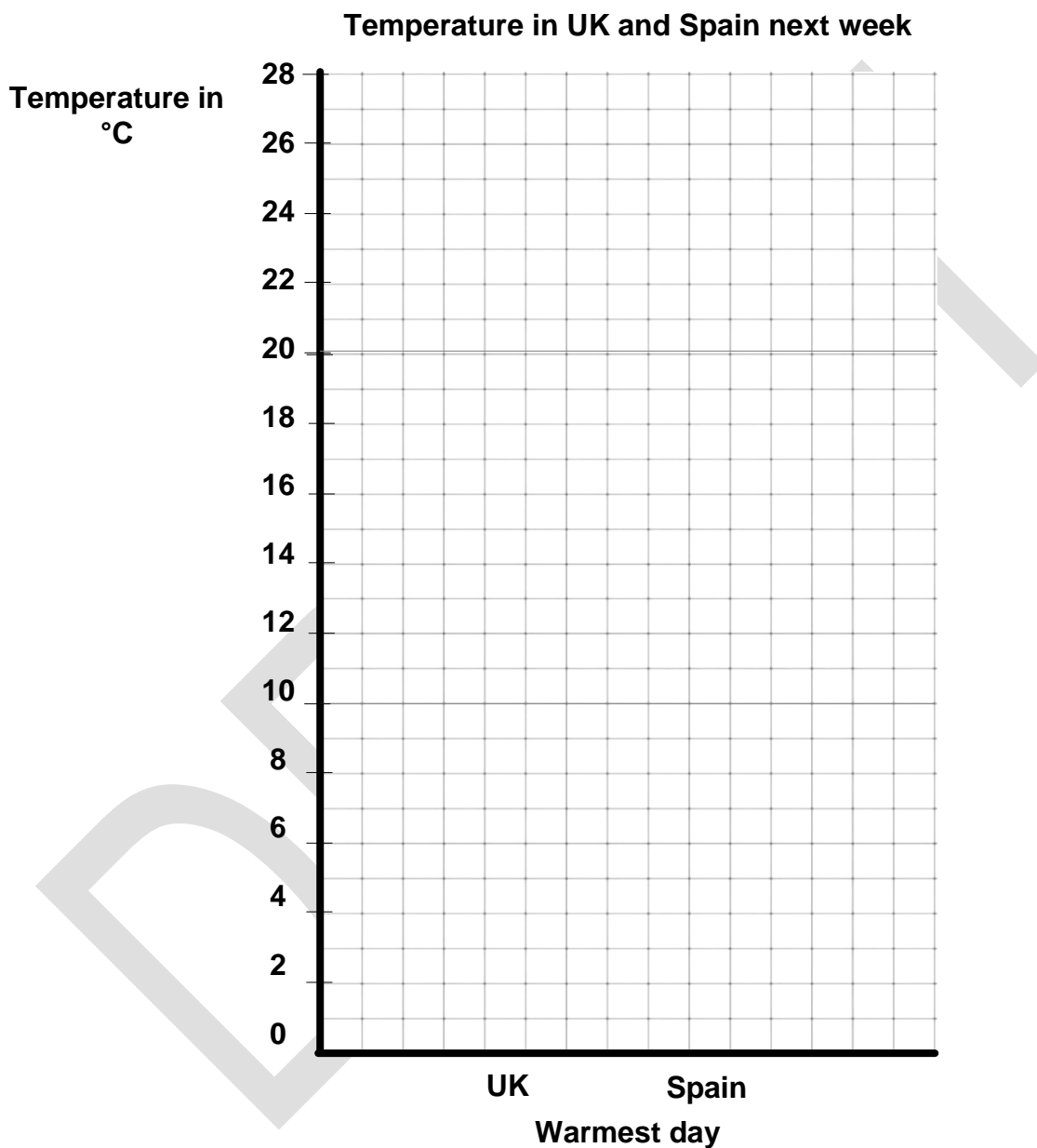

Q5. This diagram shows the maximum measurements for hand luggage that you are allowed to take on the plane.

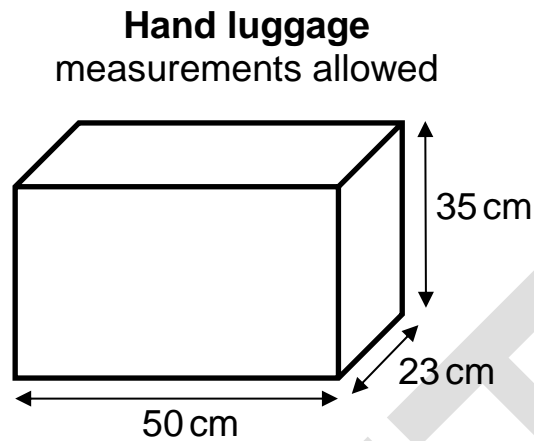

a. What is the name of the shape in the diagram?

.....

1 mark

b. What is length of the **largest** side?
Put units on your answer.

.....

1 mark

Q6. A man wants a new bag to take on the plane.

The bag is in a sale.

In the sale, all bags are half the price shown.



a. What is the price of the bag in the sale?

Show your working out.

.....

Sale price £

2 marks

The man only has these three notes.



b. How much money does he have altogether?

Show your working out.

.....
.....

Amount of money £

2 marks

c. The man buys a different bag instead. This bag costs £24 in the sale.

How much money will he have left? **Put units on your answer.**

Show your working out.

.....
.....
.....

Money left

3 marks

Q7. Here is the weight of a suitcase.

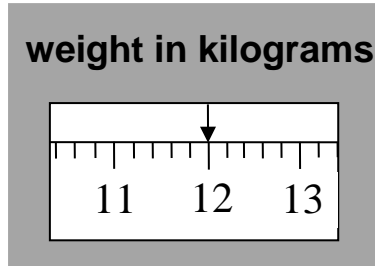

a. How much does the suitcase weigh?

..... kg

1 mark

This table shows how much it will cost to take the suitcase on the plane.

Weight of suitcase	Cost
less than 10 kg	£5
10 kg to 20 kg	£15
21 kg to 30 kg	£25
more than 30 kg	£35

b. How much will it cost to take the suitcase on the plane?

Cost £

1 mark

c. Give a reason for your answer.

.....
.....

1 mark

Q8. A flight leaves from Gate 5 at quarter to twelve.

a. Tick the clock that shows **quarter to twelve**.

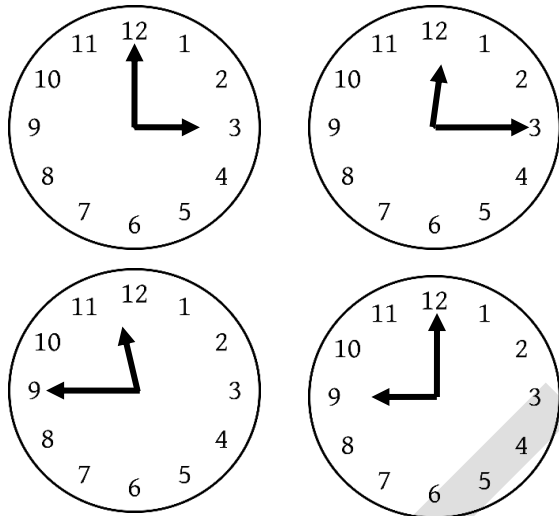

1 mark

This sign shows the Gates at the airport.

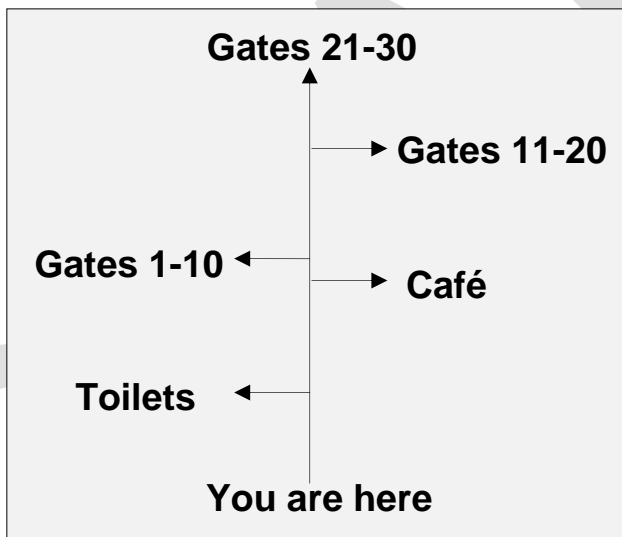

b. Put a cross (X) on the sign to show where **Gate 5** is.

1 mark

c. Write down how to get to **Gate 5**.

.....
.....
.....

1 mark

Q9. A supervisor says there are 31 passengers waiting at the check-in desks.

At Desk A there are 12 passengers

At Desk B there are 19 passengers

- a. Round the number of passengers at each desk to the **nearest ten** and use them to check if the supervisor is right.

$$\square + \square = \square$$

2 marks

Think about your answer.

- b. Write down why you think the supervisor is correct.

.....

.....

.....

.....

1 mark

Total marks: 27

End of calculator paper

Functional Skills Mathematics Entry 2 Sample Assessment



www.cityandguilds.com
March 2019
Version 0.1

Mark scheme and assessment record

Holidays

DRAFT

Assessor notes for marking

The assessor must mark the test according to the mark scheme.

- Apply the mark scheme methodically.
- Initially apply the **unshaded** section for each question.
- If this is not achieved, work down the shaded rows until you find the appropriate mark.
- If none of the shaded sections are met then award 0 for that part of the mark scheme.

The candidate's marks from each paper must be added together to get the final mark. The pass mark for the assessment is **TBC**.

The assessment record must be completed for each candidate.

DRAFT

Entry 2 Holidays - mark scheme

Candidate name: _____

	Non-calculator paper	SCS	Marks	Candidate Mark	Assessor feedback/ comments
1	58	3	1		
2	7 r4 (both parts required)	8	1		
3	45	5	1		
4	the three white squares only indicated (all three required)	24	1		
5	pentagon (do not penalise spelling)	19	1		
6	36	1	1		
7	Thursday (do not penalise spelling)	23	1		
8	toothpaste and perfume only indicated (both required)	16	1		
9	14.5	11	1		
Total marks available for non-calculator paper			9		

	Calculator paper	SCS	Marks	Candidate Mark	Assessor feedback/ comments
1	24	7	1		
2	B or 3	20	1		
3	any two squares shaded	10	1		
4a	Mon / 23, Tues / 22, Fri / 24, Sat / 26, Sun / 25 only indicated (all required) (do not penalise spelling)	17, 22	2		
	OR 4 of the above only indicated, ie one correct answer missed		(1)		
4b	Saturday (do not penalise spelling)	17	1		
4c	Wednesday (do not penalise spelling)	2	1		
4d	one bar drawn to $21 \pm \frac{1}{4}$ square	25	1		
	one bar drawn to 26 or the height for their day in $4b \pm \frac{1}{4}$ square		1		
5a	cuboid (do not penalise spelling)	19	1		
5b	50 cm or centimetres, with units (do not penalise spelling)	14	1		
6a	(£)18	8, 10	2		
	OR a correct method to find a half eg $\div 2$		(1)		
6b	(£)30 for total cash	6	2		
	OR a correct method for finding the total eg 10×3		(1)		
6c	(£)6	12	2		
	OR a correct method for finding change from £20 eg $30 - 24$		(1)		
	correct units ie £ accept pounds		1		
7a	12 (kg)	18	1		
7b	(£)15	2	1		

7c	explanation referring to 12 is more than 10 and less than 20 or similar (do not penalise spelling) <i>Follow through their weight from 7a</i>	15	1		
8a	correct clock indicated (bottom left)	13	1		
8b	Gates 1-10 indicated	22	1		
8c	clear explanation of how to get to Gates 1-10 (or the place indicated on their sign) eg Go past the toilets and the gates 1-10 are opposite the café	21	1		
9a	10 and 20 and 30	4, 9	2		
	OR 10 and 20 only OR one error rounding but correct total for their rounded values		(1)		
9b	valid comment about how the estimate is similar to the supervisor's total or slightly different because of rounding the figures or how it makes sense/is reasonable in the context	Check (5)	1		
Total marks available calculator paper			27		

DRAFT

Assessment record

Entry 2 Holidays

Name: _____**City & Guilds Enrolment Number:** _____**Date:** _____

Candidate mark for non-calculator paper	/ 9	
Candidate mark for calculator paper	/ 27	
Candidate total mark	/ 36	
Total marks available: 40	Pass mark: TBC	
PRINT Assessor name:	Signature:	Date:
PRINT IQA's Name: (if sampled)	Signature:	Date:
PRINT EQA's Name: (if sampled)	Signature:	Date:
Please indicate as applicable:		
Candidate has achieved	<input type="checkbox"/>	
Candidate has not achieved	<input type="checkbox"/>	

Published by City & Guilds
1 Giltspur Street
London
EC1A 9DD
www.cityandguilds.com

City & Guilds is a registered charity
established to promote education and
training

DRAFT