

# 6708-23 Level 2 Diploma in Plastering

July 2013 Version 1.0

PRACTICAL TASK MANUAL

# Contents

<b>Candidate details</b>	<b>2</b>
<b>Unit assessment overview</b>	<b>3</b>
Practical task completion record	3
<b>Instructions to candidates</b>	<b>6</b>
<b>Unit 221 Apply Plastering Materials to Interiors</b>	<b>7</b>
Task 1 Apply plastering material to interiors	7
<b>Unit 222 Fix Dry Lining and Plasterboards to Interiors</b>	<b>10</b>
Task 1 Apply dry lining to an interior window wall	10
Task 2 Fix plasterboards to a ceiling and a stud wall	12
<b>Unit 223 Laying Sand and Cement Screeds</b>	<b>14</b>
Task 1 Lay a floorscreed	14
Task 2 Lay a floorscreed to falls	16
<b>Unit 224 Applying Plastering Materials to External Backgrounds</b>	<b>18</b>
Task 1 Apply two coat rendering to external backgrounds	18
<b>Unit 225 Produce Reverse Moulds for Fibrous Work</b>	<b>21</b>
Task 1 Prepare for and produce a running mould	21
Task 2 Produce a reverse mould	23
<b>Unit 226 Casting and Fixing Fibrous Plasterwork</b>	<b>25</b>
Task 1 Prepare to cast and fix fibrous plasterwork	25
Task 2 Fix and finish fibrous plasterwork	27
<b>Drawings and diagrams</b>	<b>29</b>
Unit 221 Apply Plastering Materials to Interiors	29
Unit 222 Fix Dry Lining and Plasterboards to Interiors	32
Unit 223 Laying Sand and Cement Screeds	38
Unit 224 Applying Plastering Materials to External Backgrounds	40
Unit 225 Produce Reverse Moulds for Fibrous Work	41
Unit 226 Casting and Fixing Fibrous Plasterwork	44

## Candidate details



This *Practical task manual* is a record of your achievement in practical assessments. You must keep it in good condition and it must be stored in a safe place by your Assessor.

Please fill in all of your details before you carry out any assessments.

### Candidate Details

Surname		Forename(s)	
---------	--	-------------	--

City & Guilds enrolment number	
--------------------------------	--

### Centre Details

Name		Centre No	
------	--	-----------	--

I understand the requirements of the qualification and that all the work towards the assessments must be my own.

<b>Candidate signature</b> (please print)	
--	--

<b>Assessor name</b> (please print)		Signed	
--	--	--------	--

Date	
------	--

# Unit assessment overview

## Practical task completion record

### To be completed by Assessor:

For each task, the points for each grade are  
 Pass = 1, Merit = 2, and Distinction = 3 points.

†All tasks must be passed for the unit to be achieved.

Conversion chart	
Average	Overall Grade
1 – 1.5	Pass
1.6 – 2.5	Merit
2.6 – 3	Distinction

### Unit 221 Apply Plastering Materials to Interiors

Task	Grade for task
1 Apply plastering material to interiors	P / M / D / X
End of unit knowledge test	P/X

Assessor signature and date:

The overall grade will be the same as the single graded task in this unit.

Overall grade

### Unit 222 Fix Dry Lining and Plasterboards to Interiors

Task	Grade for task†	Points (graded tasks)
1 Apply dry lining to an interior window wall	P / M / D / X	
2 Fix plasterboards to a ceiling and a stud wall	P / M / D / X	
End of unit knowledge test	P/X	

Assessor signature and date:

For graded tasks, divide total points by total number of graded tasks

Average =

Overall grade  
 (see conversion chart)

**Total**

÷ 2

## Unit 223 Laying Sand and Cement Screeds

Task	Grade for task <sup>†</sup>	Points (graded tasks)
1 Lay a floorscreed	P / M / D / X	
2 Lay a floorscreed to falls	P / M / D / X	
End of unit knowledge test	P/X	
<b>Total</b>		
For graded tasks, divide total points by total number of graded tasks		÷ 2
Average =		
<b>Overall grade</b> (see conversion chart)		

Assessor signature and date:

## Unit 224 Applying Plastering Materials to External Backgrounds

Task	Grade for task
1 Apply two coat rendering to external backgrounds	P / M / D / X
End of unit knowledge test	P/X

Assessor signature and date:	The overall grade will be the same as the single graded task in this unit.	<b>Overall grade</b>

## Unit 225 Produce Reverse Moulds for Fibrous Work

Task	Grade for task <sup>†</sup>	Points (graded tasks)
1 Prepare for and produce a running mould	P / M / D / X	
2 Producing reverse moulds	P / M / D / X	
End of unit knowledge test	P/X	
<b>Total</b>		
For graded tasks, divide total points by total number of graded tasks		÷ 2
Average =		
<b>Overall grade</b> (see conversion chart)		

Assessor signature and date:

## Unit 226 Casting and Fixing Fibrous Plasterwork

Task	Grade for task <sup>†</sup>	Points (graded tasks)
1 Prepare to cast and fix fibrous plasterwork	P / M / D / X	
2 Fix and finish fibrous plasterwork	P / M / D / X	
End of unit knowledge test	P/X	
<b>Total</b>		
For graded tasks, divide total points by total number of graded tasks		÷ 2
Average =		
<b>Overall grade</b> (see conversion chart)		

Assessor signature and date:

### Authenticity and IQA/QC sampling

The assessor's signature on individual tasks will be taken as assurance that the judgements recorded are made on authentic candidate work produced under appropriate conditions. Please complete the declaration below to confirm this is the case.

I confirm that all tasks were conducted under conditions designed to assure the authenticity of the candidate's work, and am satisfied that, to the best of my knowledge, the work assessed was solely that of the candidate.	
I have judged all assessments against the relevant assessment and grading criteria and award the candidate the unit grades as calculated above.	
Assessor signature	Date
*IQA signature and date	*QC signature and date

\*IQA and QC signatures attest to the evidence available on the recorded date(s).

# Instructions to candidates

## About this document

This *Practical task manual* contains all of the practical assessment for 6708-23 Level 2 Diploma in Plastering.

## Practical tasks

These tasks let you show your practical skills and are usually graded pass, merit or distinction – a few are pass only. These tasks will be assessed by your assessor watching how you carry out the tasks and checking your final pieces of work.

Before you carry out the task you will be told how it will be assessed and you should read the observation checklist at the end of each task so you know what you need to do to get each grade.

You can ask your assessor for help in understanding the task instructions, but all of the work must be your own.

## Health and safety

You must use safe working practices at all times.

You are responsible for your own safety and the safety of others. If you behave in an unsafe way, you will be stopped and given a warning. If you do not meet all of the Health and Safety requirements, the assessment will be stopped. Your assessor will not be able to let you try the task again until they are sure you can work safely.

## Time considerations

Each task shows how long it is likely to take. This is for guidance and so you can plan your work. If you have a good reason for needing more time you must explain this to your assessor as soon as possible so they can decide whether you can have more time.

## Security

Where an assignment is taken over more than one session, all documentation, paperwork and work products must be labelled carefully with your name and kept securely at the centre. Your assessor will give you directions about how to leave your work.

## Opportunities to repeat tasks

The tasks are 'end tests' so you will only be asked to take the assessment when you have had the chance to do all of the learning and practice you need. You will be able to try the whole task again if you do not pass, but you will not be able to take the assessment again just to try to get a better grade.

## Feedback

As well as telling you the result for the task your assessor will give you feedback. They will give you a feedback sheet with details of what you could do to improve, and also what you did well in. This will help you to prepare for other assessments or to retake the assessment if you need to.

# Unit 221 Apply Plastering Materials to Interiors

## Task 1 Apply plastering material to interiors

<b>Expected time</b>	9 hours
<b>Task instructions</b>	<ul style="list-style-type: none"> <li>• Apply one, two and three-coat plastering to interior backgrounds.</li> <li>• Prepare backgrounds ready to receive two coat plaster work.</li> <li>• Fix EML to a wall plate.</li> <li>• Fix angle beads to external angles around the window.</li> <li>• Apply pricking up coat and key EML with suitable undercoat plaster.</li> <li>• Apply a backing plaster to a maximum thickness of 11 mm to wall, attached pier, reveals and soffit.</li> <li>• Apply a finish plaster in two applications to ceiling, wall, attached pier, reveals and soffit.</li> <li>• Follow relevant environmental and health and safety regulations.</li> </ul>
<b>Diagrams</b>	<p>Figure 1: Specification for internal plasterwork - page 29</p> <p>Figure 2: EML fixed to a timber wall plate - page 30</p> <p>Figure 3: Sectioned front view of three coat plasterwork to window and attached pier – page 31</p>

### Observation checklist

AC	The candidate has	Pass	Merit	Distinction
2.1 2.2 4.2	checked and complied with information relating to drawings and specification	<input type="checkbox"/>		
2.3	interpreted manufacturers' information relating to interior plasterwork <ul style="list-style-type: none"> <li>• data sheets</li> </ul>	<input type="checkbox"/>		
2.4	reported discrepancies in the drawings or specification to authorised personnel or answered questions about discrepancy procedure correctly	<input type="checkbox"/>		
4.1	selected materials for interior work <ul style="list-style-type: none"> <li>• lightweight gypsum backing plaster</li> <li>• lightweight finishing plaster</li> <li>• EML</li> <li>• plaster beads</li> </ul>	<input type="checkbox"/>		
4.3	selected hand and power tools for interior work	<input type="checkbox"/>		
4.4	checked for correct access equipment for work	<input type="checkbox"/>		



AC	The candidate has	Pass	Merit	Distinction
6.1	prepared backgrounds high and low suction <ul style="list-style-type: none"> <li>• clean off</li> <li>• check suction</li> <li>• prepare plasterboard joints</li> </ul>	<input type="checkbox"/>		
6.2	installed expanded metal lath (EML) in narrow strips	<input type="checkbox"/> fixed accurately to given measurements within 15 mm	<input type="checkbox"/> fixed accurately to given measurements within 10 mm	<input type="checkbox"/> fixed accurately to given measurements within 5 mm
6.3	mixed plastering materials	<input type="checkbox"/>		
6.4	* applied and finished one, two and three-coat work to solid and applied backgrounds	<input type="checkbox"/> applied material plumb $\pm 3$ mm, maximum of 4 minor blemishes	<input type="checkbox"/> applied material plumb $\pm 3$ mm, maximum of 3 minor blemishes	<input type="checkbox"/> applied material plumb $\pm 3$ mm, maximum of 2 minor blemishes
	* applied and finished one, two and three-coat work to reveals and soffits	<input type="checkbox"/> applied material plumb and square $\pm 3$ mm, maximum of 2 minor blemishes	<input type="checkbox"/> applied material plumb and square $\pm 3$ mm, maximum of 1 minor blemishes	<input type="checkbox"/> applied material plumb and square $\pm 3$ mm, no minor blemishes
	* applied and finished one, two and three-coat work to attached pier	<input type="checkbox"/> applied material plumb and square $\pm 3$ mm, maximum of 4 minor blemishes	<input type="checkbox"/> applied material plumb and square $\pm 3$ mm, maximum of 3 minor blemishes	<input type="checkbox"/> applied material plumb and square $\pm 3$ mm, maximum of 2 minor blemishes
	* applied finish coat to ceiling	<input type="checkbox"/> applied material to a flat and smooth finish, maximum of 5 minor blemishes	<input type="checkbox"/> applied material to a flat and smooth finish, maximum of 4 minor blemishes	<input type="checkbox"/> applied material to a flat and smooth finish, maximum of 3 minor blemishes
6.5	formed external angles using pre-formed beads and trims to reveals and soffits	<input type="checkbox"/> angle beads fixed flush, plumb and level within $\pm 4$ mm	<input type="checkbox"/> angle beads fixed flush, plumb and level within $\pm 3$ mm	<input type="checkbox"/> angle beads fixed flush, plumb and level within $\pm 2$ mm
	formed external angles using pre-formed beads and trims to attached pier	<input type="checkbox"/> angle bead fixed plumb $\pm 4$ mm	<input type="checkbox"/> angle bead fixed plumb $\pm 3$ mm	<input type="checkbox"/> angle bead fixed plumb $\pm 2$ mm
6.6	formed external angles without pre-formed beads and trims (hard angles)	<input type="checkbox"/> angle plumb $\pm 4$ mm	<input type="checkbox"/> angle plumb $\pm 3$ mm	<input type="checkbox"/> angle plumb $\pm 2$ mm

AC	The candidate has	Pass	Merit	Distinction
6.7	used correct access equipment for work	<input type="checkbox"/>		
6.8	followed current environmental and current health and safety regulations throughout the tasks	<input type="checkbox"/>		

Task grading rules		Task grade:
To award a <b>pass</b> : every activity in the checklist must be successfully achieved.		
To award a <b>merit</b> : in addition to the above, <b>6</b> out of <b>8</b> graded activities in the checklist must be achieved to <b>at least</b> a merit standard, including all essential activities (marked with *).		
To award a <b>distinction</b> : <b>6</b> out of <b>8</b> graded activities in the checklist must be achieved to <b>at least</b> a distinction standard, including all of the essential activities (marked with *); in addition <b>all</b> the remaining graded activities must be achieved to <b>at least</b> a merit standard.		
Assessor	Signature & Date	

# Unit 222 Fix Dry Lining and Plasterboards to Interiors

## Task 1 Apply dry lining to an interior window wall

<b>Expected time</b>	10 hours
<b>Task instructions</b>	<ul style="list-style-type: none"> <li>• Apply dry lining using adhesive compounds to a background and window opening reveals and attached pier.</li> <li>• Form perimeter seal and external angle to boards.</li> <li>• Form joints by hand or mechanically.</li> <li>• Follow relevant environmental and health and safety regulations.</li> </ul>
<b>Diagrams</b>	Figure 1: Applied direct bond to window wall - page 32 Figure 2: Applied direct bond to window wall - page 33

### Observation checklist

AC	The candidate has	Pass	Merit	Distinction
2.1 2.2 4.1	checked, interpreted and complied with information relating to drawings and specification	<input type="checkbox"/>		
2.3	interpreted manufacturers' information relating to fixing dry lining <ul style="list-style-type: none"> <li>• data sheets</li> </ul>	<input type="checkbox"/>		
4.2	selected materials and components for fixing dry lining	<input type="checkbox"/>		
4.3	selected tools and equipment for fixing dry lining	<input type="checkbox"/>		
4.4 6.6	selected and used correct access equipment to carry out dry lining	<input type="checkbox"/>		
2.4	reported discrepancies in the drawings or specification to authorised personnel by answering question about discrepancy procedure correctly	<input type="checkbox"/>		
4.5	reported discrepancies in materials or components to authorised personnel or answered question about discrepancy procedure correctly	<input type="checkbox"/>		

AC	The candidate has	Pass	Merit	Distinction
6.1	applied direct bond dry lining using adhesive compounds to vertical solid backgrounds and returns	<input type="checkbox"/> applied adhesive to uniform thickness and correct intervals included continuous fillets		
		<input type="checkbox"/> wall, pier, reveals and all returns plumb, level and square within $\pm 3$ mm		
		<input type="checkbox"/> gaps in joints less than 5 mm	<input type="checkbox"/> gaps in joints less than 3 mm	<input type="checkbox"/> joints tightly butted with no steps and correctly aligned, face of boards clean and free from adhesive
6.4	formed perimeter seal and external angle to boards	<input type="checkbox"/>		
6.3	formed joints by hand or mechanically to straight joints and internal and external angles	<input type="checkbox"/> joints formed correctly with maximum of 2 minor imperfections	<input type="checkbox"/> joints formed correctly no imperfections	
6.5 6.7	followed current environmental and health and safety regulations throughout including protecting the surrounding environment	<input type="checkbox"/>		

Task grading rules	Task grade:
To award a <b>pass</b> : every activity in the checklist must be successfully achieved.	
To award a <b>merit</b> : in addition to the above, the <b>2</b> graded activities in the checklist must be achieved to <b>at least</b> a merit standard.	
To award a <b>distinction</b> : in addition to both of the above, the <b>1</b> graded activity in the checklist must be achieved to a distinction standard.	
Assessor	Signature & Date

# Unit 222 Fix dry lining and plasterboards to interiors

## Task 2 Fix plasterboards to a ceiling and a stud wall

<b>Expected time</b>	4 hours
<b>Task instructions</b>	<ul style="list-style-type: none"> <li>Plasterboard a ceiling and a stud wall using mechanical fixings.</li> <li>Follow relevant environmental and health and safety regulations.</li> </ul>
<b>Diagrams</b>	<p>Figure 1: Before: ceiling joist position - page 34</p> <p>Figure 2: After: ceiling joists with fixed plasterboards - page 35</p> <p>Figure 3: Before: timber stud partition - page 36</p> <p>Figure 4: After: timber stud partition with fixed plasterboards - page 37</p>

### Observation checklist

AC	The candidate has	Pass	Merit	Distinction
2.1 2.2 4.1	checked, interpreted and complied with information relating to the drawing	<input type="checkbox"/>		
2.3	interpreted manufacturers' information relating to fixing plasterboards <ul style="list-style-type: none"> <li>data sheets</li> </ul>	<input type="checkbox"/>		
4.2	selected materials and components for fixing plasterboards	<input type="checkbox"/>		
4.3	selected tools and equipment for fixing plasterboards	<input type="checkbox"/>		
4.4 6.6	selected and used correct access equipment	<input type="checkbox"/>		
6.2	installed and fixed plasterboards using mechanical fixings to ceiling joists	<input type="checkbox"/> boards measured, cut, fixed, staggered and aligned correctly		
		<input type="checkbox"/> used correct fixings at correct centres and to correct depth	<input type="checkbox"/> all fixings and centres accurate and to correct depth	
		<input type="checkbox"/> all joints butted	<input type="checkbox"/> all joints between 3-5 mm	<input type="checkbox"/> all joints between 2-3 mm

AC	The candidate has	Pass	Merit	Distinction
6.2	installed and fixed plasterboards using mechanical fixings to a timber or steel stud partition	<input type="checkbox"/> boards measured, cut, fixed, staggered and aligned correctly		
		<input type="checkbox"/> used correct fixings at correct centres and to correct depth	<input type="checkbox"/> all fixings inline and centres accurate and to correct depth	
		<input type="checkbox"/> all joints butted	<input type="checkbox"/> all joints between 3-5 mm	<input type="checkbox"/> all joints between 2-3 mm
6.5 6.7	followed current environmental and health and safety regulations throughout including protecting the surrounding environment			

Task grading rules		Task grade:
To award a <b>pass</b> : every activity in the checklist must be successfully achieved.		
To award a <b>merit</b> : in addition to the above, all <b>4</b> graded activities in the checklist must be achieved to <b>at least</b> a merit standard.		
To award a <b>distinction</b> : in addition to both of the above, the <b>2</b> graded activities in the checklist must be achieved to a distinction standard.		
Assessor	Signature & Date	

# Unit 223 Laying Sand and Cement Screeds

## Task 1 Lay a floorscreed

<b>Expected time</b>	4 hours
<b>Task instructions</b>	<ul style="list-style-type: none"> <li>• Prepare sub-floors.</li> <li>• Set up battens and screeds.</li> <li>• Gauge and mix materials.</li> <li>• Lay and finish a floorscreed to level to an area of 5 m<sup>2</sup>.</li> <li>• Follow relevant environmental and health and safety regulations.</li> </ul>
<b>Diagrams</b>	Figure 1: Specification for sand and cement floorscreed - page 38

### Observation checklist

AC	The candidate has	Pass	Merit	Distinction
2.1 2.2 4.1	checked, interpreted and complied with information relating to the drawing and specification	<input type="checkbox"/>		
2.3	interpreted manufacturers' information relating to laying sand and cement screeds <ul style="list-style-type: none"> <li>• data sheets</li> </ul>	<input type="checkbox"/>		
2.4	reported discrepancies in the drawing or specification to authorised personnel or answered question about discrepancy procedure correctly	<input type="checkbox"/>		
4.2	selected materials for laying sand and cement screeds	<input type="checkbox"/>		
4.3	selected tools and equipment for laying sand and cement screeds	<input type="checkbox"/>		
4.4	reported discrepancies in materials or equipment to authorised personnel or answered question about discrepancy procedure correctly	<input type="checkbox"/>		
6.1	prepared background areas (sub-floors)	<input type="checkbox"/>		
6.2 6.3	set up battens and screeds and set up for levels using levelling equipment	<input type="checkbox"/> all 4 battens set to $\pm 6$ mm from datum line	<input type="checkbox"/> all 4 battens set to $\pm 4$ mm from datum line	<input type="checkbox"/> all 4 battens set accurately level from datum line
6.4	correctly gauged and mixed the materials to a semi-dry consistency	<input type="checkbox"/>		

AC	The candidate has	Pass	Merit	Distinction
6.5	laid and finished floorscreeds to levels	<input type="checkbox"/> screed laid to correct uniform thickness, compacted and consolidated		
		<input type="checkbox"/> level and flat $\pm 10$ mm across a 3 m rule	<input type="checkbox"/> level and flat $\pm 5$ mm across a 3 m rule	<input type="checkbox"/> level and flat $\pm 3$ mm across a 3 m rule
		<input type="checkbox"/> even finish, minor trowel marks and blemishes		<input type="checkbox"/> even finish, free from trowel marks and blemishes
6.6	maintained tools and equipment	<input type="checkbox"/>		
6.7	followed current environmental and current health and safety regulations	<input type="checkbox"/>		

Task grading rules		Task grade:
To award a <b>pass</b> : every activity in the checklist must be successfully achieved.		
To award a <b>merit</b> : in addition to the above, the <b>2</b> graded activities in the checklist must be achieved to <b>at least</b> a merit standard.		
To award a <b>distinction</b> : in addition to both of the above, all <b>3</b> graded activities in the checklist must be achieved to a distinction standard.		
Assessor	Signature & Date	



# Unit 223 Laying Sand and Cement Screeds

## Task 2 Lay a floorscreed to falls

<b>Expected time</b>	4 hours
<b>Task instructions</b>	<ul style="list-style-type: none"> <li>• Prepare sub-floors.</li> <li>• Set up battens and screeds.</li> <li>• Gauge and mix materials.</li> <li>• Lay a floorscreed to falls to an area of 5 m<sup>2</sup>.</li> <li>• Follow relevant environmental and health and safety regulations.</li> </ul>
<b>Diagrams</b>	Figure 1: Specification for sand and cement floorscreed to falls - page 39

### Observation checklist

AC	The candidate has	Pass	Merit	Distinction
2.1 2.2 4.1	checked, interpreted and complied with information relating to drawing and specification	<input type="checkbox"/>		
2.3	interpreted manufacturers' information relating to laying sand and cement screeds <ul style="list-style-type: none"> <li>• data sheets</li> </ul>	<input type="checkbox"/>		
4.2	selected materials for laying sand and cement screeds	<input type="checkbox"/>		
4.3	selected tools and equipment for laying sand and cement screeds	<input type="checkbox"/>		
6.1	prepared background areas (sub-floors)	<input type="checkbox"/>		
6.2 6.3	set up battens and screeds and set up for levels and falls using levelling equipment	<input type="checkbox"/> all 4 battens set to $\pm 6$ mm from datum line	<input type="checkbox"/> all 4 battens set to $\pm 4$ mm from datum line	<input type="checkbox"/> all 4 battens set to an accurate fall from datum line
6.4	correctly gauged and mixed the materials to a semi-dry consistency	<input type="checkbox"/>		

AC	The candidate has	Pass	Merit	Distinction
6.5	laid and finished floorscreeds to falls	<input type="checkbox"/> screed laid to correct uniform thickness, flat $\pm 10$ mm across a 3 m rule	<input type="checkbox"/> screed laid to correct uniform thickness, level and flat $\pm 5$ mm across a 3 m rule	<input type="checkbox"/> screed laid to correct uniform thickness, level and flat $\pm 3$ mm across a 3 m rule
		<input type="checkbox"/> correct fall and minimum thickness at fall, even finish		
		<input type="checkbox"/> minor trowel marks and blemishes		<input type="checkbox"/> free from trowel marks and blemishes
6.6	maintained tools and equipment	<input type="checkbox"/>		
6.7	followed current environmental and current health and safety regulations	<input type="checkbox"/>		

Task grading rules		Task grade:
To award a <b>pass</b> : every activity in the checklist must be successfully achieved.		
To award a <b>merit</b> : in addition to the above, the <b>2</b> graded activities in the checklist must be achieved to <b>at least</b> a merit standard.		
To award a <b>distinction</b> : in addition to both of the above, all <b>3</b> graded activities in the checklist must be achieved to a distinction standard.		
Assessor	Signature & Date	

## Unit 224 Applying Plastering Materials to External Backgrounds

### Task 1 Apply two coat rendering to external backgrounds

<b>Expected time</b>	10 hours
<b>Task instructions</b>	<ul style="list-style-type: none"> <li>• Prepare background including cleaning and checking suction.</li> <li>• Apply beads and form external angles without pre-formed beads.</li> <li>• Mix rendering materials.</li> <li>• Provide a plain face render finish and a pre-mixed through coloured render finish to the areas as shown in the diagram.</li> <li>• Follow relevant environmental and health and safety regulations.</li> </ul>
<b>Diagrams</b>	Figure 1: External rendering specification - page 40

#### Observation checklist

AC	The candidate has	Pass	Merit	Distinction
2.1 2.2 4.2	checked and complied with information relating to drawing and specification	<input type="checkbox"/>		
2.3	interpreted manufacturers' information relating to external plasterwork <ul style="list-style-type: none"> <li>• data sheets</li> </ul>	<input type="checkbox"/>		
2.4	reported discrepancies in the drawing or specification to authorised personnel or answered question about discrepancy correctly	<input type="checkbox"/>		
4.1	selected materials for external work	<input type="checkbox"/>		
4.3	selected hand tools for external work	<input type="checkbox"/>		
4.4	checked for suitable access equipment for work	<input type="checkbox"/>		
6.1	prepared backgrounds high and low suction <ul style="list-style-type: none"> <li>• clean off</li> <li>• check suction</li> </ul>	<input type="checkbox"/>		
6.2	mixed rendering materials	<input type="checkbox"/>		

AC	The candidate has	Pass	Merit	Distinction
6.3	fixed pre-formed bell beads and trims	<input type="checkbox"/> beads cut within $\pm 7$ mm	<input type="checkbox"/> beads cut within $\pm 5$ mm attempts made to mitre at corners	<input type="checkbox"/> beads cut within $\pm 3$ mm and mitred accurately
		<input type="checkbox"/> beads fixed using appropriate methods, plumb and level within $\pm 3$ mm		
6.4	formed external angles without pre-formed beads and trims	<input type="checkbox"/> external angles formed using appropriate methods, plumb and straight within $\pm 3$ mm		
		<input type="checkbox"/> finished to a sharp accurate arris along a minimum of 60% of its length	<input type="checkbox"/> finished to a sharp accurate arris along a minimum of 75% of its length	<input type="checkbox"/> finished to a sharp accurate arris along the whole length
6.5	*applied and finished two coat work to external backgrounds – plain faced finish	<input type="checkbox"/> flat, lineable and plumb within $\pm 3$ mm along a 1.8 m rule		
		<input type="checkbox"/> uniform finish free from deviation or blemishes to a minimum 80% of surface area, accurate finish to beads	<input type="checkbox"/> uniform finish free from deviation or blemishes to a minimum 90% of surface area, accurate finish to beads	<input type="checkbox"/> uniform finish free from deviation or blemishes, accurate finish to beads

AC	The candidate has	Pass	Merit	Distinction
6.5	*applied and finished two coat work to external backgrounds – pre-mixed through colour render	<input type="checkbox"/> flat, lineable and plumb within $\pm 3$ mm along a 1.8 m rule		
		<input type="checkbox"/> uniform finish free from deviation or blemishes to a minimum 80% of surface area, accurate finish to beads	<input type="checkbox"/> uniform finish free from deviation or blemishes to a minimum 90% of surface area, accurate finish to beads	<input type="checkbox"/> uniform finish free from deviation or blemishes, accurate finish to beads
6.6	used correct access equipment for the work	<input type="checkbox"/>		
4.5 6.7	followed current environmental and current health and safety regulations throughout tasks	<input type="checkbox"/>		

Task grading rules		Task grade:
To award a <b>pass</b> : every activity in the checklist must be successfully achieved.		
To award a <b>merit</b> : in addition to the above, <b>3</b> out of <b>4</b> graded activities in the checklist must be achieved to <b>at least</b> a merit standard, including all essential activities (marked with *).		
To award a <b>distinction</b> : <b>3</b> out of <b>4</b> graded activities in the checklist must be achieved to <b>at least</b> a distinction standard including all essential activities (marked with *), and <b>1</b> of the remaining graded activities must be achieved to <b>at least</b> a merit standard.		
Assessor	Signature & Date	

# Unit 225 Produce Reverse Moulds for Fibrous Work

## Task 1 Prepare for and produce a running mould

<b>Expected time</b>	6 hours
<b>Task instructions</b>	<ul style="list-style-type: none"> <li>Construct a running mould according to the drawing and specification, using the correct tools and equipment.</li> <li>Draw and cut out metal template.</li> <li>Follow relevant environmental and health and safety regulations.</li> </ul>
<b>Diagrams</b>	<p>Figure 1: Specification for constructing the running mould (profile of cornice) - page 41</p> <p>Figure 2: Reverse running mould - page 42</p>

### Observation checklist

AC	The candidate has	Pass	Merit	Distinction
2.1 2.2 4.1	checked and complied with information provided on the drawings and specifications	<input type="checkbox"/>		
4.2	selected correct materials to produce a running mould	<input type="checkbox"/>		
4.3	selected tools and equipment to produce a running mould	<input type="checkbox"/>		
2.4	reported discrepancies in the drawing or specification to authorised personnel or answered question about discrepancy procedure correctly	<input type="checkbox"/>		
4.4	reported discrepancies in materials or equipment to authorised personnel or answered question about discrepancy procedure correctly	<input type="checkbox"/>		
2.1 2.2 6.1	produced running mould according to drawing and specification to include: <ul style="list-style-type: none"> <li>drawing template</li> <li>cutting out metal template</li> </ul> using correct techniques	<input type="checkbox"/> mould profile is within $\pm 5$ mm	<input type="checkbox"/> mould profile is within $\pm 3$ mm	<input type="checkbox"/> mould profile is within $\pm 2$ mm
2.5 4.5 6.5	followed current environmental and current health and safety regulations throughout	<input type="checkbox"/>		

Task grading rules		Task grade:
To award a <b>pass</b> : every activity in the checklist must be successfully achieved.		
To award a <b>merit</b> : in addition to the above, the <b>1</b> graded activity in the checklist must be achieved to <b>at least</b> a merit standard.		
To award a <b>distinction</b> : in addition to both of the above, the <b>1</b> graded activity in the checklist must be achieved to a distinction standard.		
Assessor	Signature & Date	

# Unit 225 Produce Reverse Moulds for Fibrous Work

## Task 2 Produce a reverse mould

<b>Expected time</b>	2 hours and 30 minutes
<b>Task instructions</b>	<ul style="list-style-type: none"> <li>• Run a reverse cornice mould to a length of 1.5 m.</li> <li>• The surface finish should be straight and smooth and cut square at both ends.</li> <li>• Follow relevant environmental and health and safety regulations.</li> </ul>
<b>Diagrams</b>	Figure 1: Specification to produce the reverse mould - page 43

### Observation checklist

AC	The candidate has	Pass	Merit	Distinction
2.1 2.2 4.1	checked and complied with information provided on the drawing and specification	<input type="checkbox"/>		
4.2	selected correct materials to produce reverse mould	<input type="checkbox"/>		
4.3	selected tools and equipment to produce reverse mould	<input type="checkbox"/>		
2.3 6.2	gauged and mixed casting plasters according to manufacturers' information <ul style="list-style-type: none"> <li>• data sheets</li> </ul>	<input type="checkbox"/>		
6.1 6.3	run reverse mould to include: <ul style="list-style-type: none"> <li>• preparing bench</li> <li>• form the core</li> <li>• applied casting plasters to form reverse</li> <li>• sealed with shellac once dried</li> <li>• protecting the mould</li> </ul>	<input type="checkbox"/> mould is run straight to a length of 1.5 m cut square within 10 mm	<input type="checkbox"/> mould is run straight to a length of 1.5 m cut square within 5 mm	<input type="checkbox"/> mould is run straight to a length of 1.5 m cut square
		<input type="checkbox"/> a maximum of 3 defects that can be made good	<input type="checkbox"/> a maximum of 2 defects that can be made good	<input type="checkbox"/> no defects in surface finish
6.4	position casts for drying and storage #			
2.5 4.5 6.5	followed current environmental and current health and safety regulations throughout	<input type="checkbox"/>		

# This AC is to be assessed in unit 226 once the mould is cast.



Task grading rules		Task grade:
To award a <b>pass</b> : every activity in the checklist must be successfully achieved.		
To award a <b>merit</b> : in addition to the above, the <b>2</b> graded activities in the checklist must be achieved to <b>at least</b> a merit standard.		
To award a <b>distinction</b> : in addition to both of the above, the <b>2</b> graded activities in the checklist must be achieved to a distinction standard.		
Assessor	Signature & Date	

# Unit 226 Casting and Fixing Fibrous Plasterwork

## Task 1 Prepare to cast and fix fibrous plasterwork

<b>Expected time</b>	1 hour and 30 minutes
<b>Task instructions</b>	<ul style="list-style-type: none"> <li>• Prepare reverse mould.</li> <li>• Cut reinforcement and canvas.</li> <li>• Gauge and mix materials.</li> <li>• Cast lengths of fibrous cornice from a reverse mould.</li> <li>• Follow relevant environmental and health and safety regulations.</li> </ul>
<b>Diagrams</b>	Figure 1: Profile of cornice - page 44 Figure 2: Specification for casting - page 45

### Observation checklist

AC	The candidate has	Pass	Merit	Distinction
2.1 2.2 4.1	checked and complied with information provided on the drawings and specification	<input type="checkbox"/>		
4.2	selected correct materials to produce cast	<input type="checkbox"/>		
4.3	selected tools and equipment to produce cast	<input type="checkbox"/>		
2.4	reported discrepancies in information to authorised personnel or answered question about discrepancy procedure correctly	<input type="checkbox"/>		
4.4	reported discrepancies in material and equipment to authorised personnel or answered question about discrepancy procedure correctly	<input type="checkbox"/>		
6.1	prepared reverse mould to include: <ul style="list-style-type: none"> <li>• free from dust</li> <li>• coated with release agent</li> </ul>	<input type="checkbox"/>		
6.2	cut reinforcement and canvas	<input type="checkbox"/>		
2.3 6.3	gauged and mixed materials <ul style="list-style-type: none"> <li>• interpreted manufacturer's information</li> <li>• data sheets</li> </ul>	<input type="checkbox"/>		

AC	The candidate has	Pass	Merit	Distinction
6.4	applied materials and reinforcement to include: <ul style="list-style-type: none"> <li>• correct use of tools and equipment</li> <li>• followed correct procedures</li> <li>• surface finish of the cast</li> </ul>	<input type="checkbox"/> canvas grinning through surface finish on 2 lengths	<input type="checkbox"/> canvas grinning through surface finish on 1 length	<input type="checkbox"/> canvas in correct position and not grinning through surface finish on all lengths
		<input type="checkbox"/> 4 laths correctly positioned, and parallel with strike	<input type="checkbox"/> 5 laths correctly positioned, and parallel with strike	<input type="checkbox"/> all laths correctly positioned, and parallel with strike off
		<input type="checkbox"/> surface finish maximum of 6 minor imperfections on each cast	<input type="checkbox"/> surface finish with maximum of 4 minor imperfections on each cast	<input type="checkbox"/> surface finish with maximum of 3 minor imperfections on each cast
6.5	positioned casts for drying and storage to include: <ul style="list-style-type: none"> <li>• vertically</li> <li>• tied</li> <li>• face-to –face</li> </ul>	<input type="checkbox"/>		
2.5 4.5 6.6	followed current environmental and current health and safety regulations throughout task	<input type="checkbox"/>		

Task grading rules		Task grade:
To award a <b>pass</b> : every activity in the checklist must be successfully achieved.		
To award a <b>merit</b> : in addition to the above, all <b>3</b> graded activities in the checklist must be achieved to <b>at least</b> a merit standard.		
To award a <b>distinction</b> : in addition to both of the above, all <b>3</b> graded activities in the checklist must be achieved to a distinction standard.		
Assessor	Signature & Date	

# Unit 226 Casting and Fixing Fibrous Plasterwork

## Task 2 Fix and finish fibrous plasterwork

<b>Expected time</b>	6 hours
<b>Task instructions</b>	<ul style="list-style-type: none"> <li>• Prepare materials for fixing and finishing.</li> <li>• Pre-drill pilot holes.</li> <li>• Position and fix a fibrous cornice to include:               <ul style="list-style-type: none"> <li>○ 1 external mitre</li> <li>○ 1 internal mitre</li> <li>○ 2 stop ends</li> <li>○ 1 straight joint.</li> </ul> </li> <li>• Make good and finish.</li> <li>• Follow relevant environmental and health and safety regulations.</li> </ul>
<b>Diagrams</b>	Figure 1: Profile of cornice - page 44 Figure 2: Specification for casting - page 45

### Observation checklist

AC	The candidate has	Pass	Merit	Distinction
8.1	prepared materials for fixing and finishing	<input type="checkbox"/>		
8.2	selected tools and equipment for fixing and finishing	<input type="checkbox"/>		
8.3	pre-drilled pilot holes for fixing fibrous plaster to prepared points	<input type="checkbox"/>		
8.4	positioned and secured fibrous casts <ul style="list-style-type: none"> <li>• marked projection and depth</li> <li>• prepared background</li> <li>• measured and cut lengths and mitres</li> <li>• positioned and fixed casts</li> </ul>	<input type="checkbox"/> all lengths and mitres cut accurately at third attempt	<input type="checkbox"/> all lengths and mitres cut accurately at second attempt	<input type="checkbox"/> all lengths and mitres cut accurately at first attempt
		<input type="checkbox"/> cut, set out and positioned cast to the correct measurement $\pm 15$ mm to the stop end	<input type="checkbox"/> cut, set out and positioned cast to the correct measurement $\pm 10$ mm to the stop end	<input type="checkbox"/> cut, set out and positioned cast to the correct measurement $\pm 5$ mm to the stop end

AC	The candidate has	Pass	Merit	Distinction
8.5	made good and finished	<input type="checkbox"/> all gaps along projection and depth to be stopped and cleaned	<input type="checkbox"/> all gaps along projection and depth to be stopped and cleaned with a maximum of 2 minor imperfections	<input type="checkbox"/> all gaps along projection and depth to be stopped and cleaned with no imperfections
		<input type="checkbox"/> all mitres and joints are finished, a minimum of 3 must be sharp and aligned	<input type="checkbox"/> all mitres and joints are finished, a minimum of 4 must be sharp and aligned	<input type="checkbox"/> all mitres and joints are finished sharp and aligned
8.6	used correct access equipment for work	<input type="checkbox"/>		
8.7	followed current environmental and current health and safety regulations throughout task	<input type="checkbox"/>		

Task grading rules		Task grade:
To award a <b>pass</b> : every activity in the checklist must be successfully achieved.		
To award a <b>merit</b> : in addition to the above, <b>3</b> out of <b>4</b> graded activities in the checklist must be achieved to <b>at least</b> a merit standard.		
To award a <b>distinction</b> : <b>3</b> out of <b>4</b> graded activities in the checklist must be achieved to <b>at least</b> a distinction standard, and <b>1</b> of the remaining graded activities must be achieved to <b>at least</b> a merit standard.		
Assessor	Signature & Date	

## Drawings and diagrams

### Unit 221 Apply Plastering Materials to Interiors

#### Task 1 Apply plastering material to interiors

Figure 1: Specification for internal plasterwork

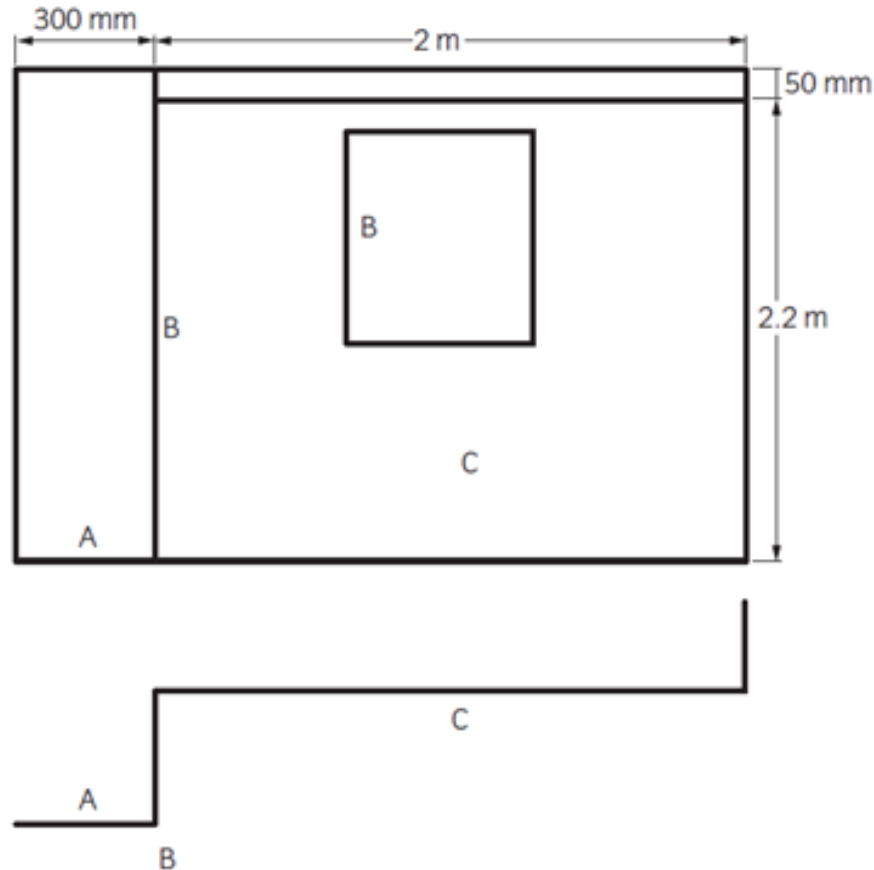

#### Specification

Internal block/brick wall and attached pier to be finished with 11 mm of a suitable backing plaster and a further 2-3 mm setting coat.

Ceiling to be finished with a 2 mm setting coat. All internal and external angles should be left clean.

Setting coat on both walls and ceiling should be left suitable to receive a paint finish.

A light pricking up coat of backing plaster to be applied across the EML. The EML must cover the wall plate with at least a 15mm overhang or in the absence of a wall plate it must be fixed along the ceiling line.

Broad/box screed method can be used after EML has been covered or standard angle beads can be used as screeds when floating the wall.

- A. Backing plaster applied to attached pier using the reverse rule method to form a hard corner.
- B. Skim on top of floated arris on attached pier (thin coat bead to be used on top of float coat).

Standard angle beads to be fixed around the window opening with appropriate plaster.

- C. Apply backing plaster and setting coat to the window wall, reveals, soffit and attached pier.

## Drawings and diagrams

### Unit 221 Apply Plastering Materials to Interiors

#### Task 1 Apply plastering material to interiors

Figure 2: EML fixed to a timber wall plate

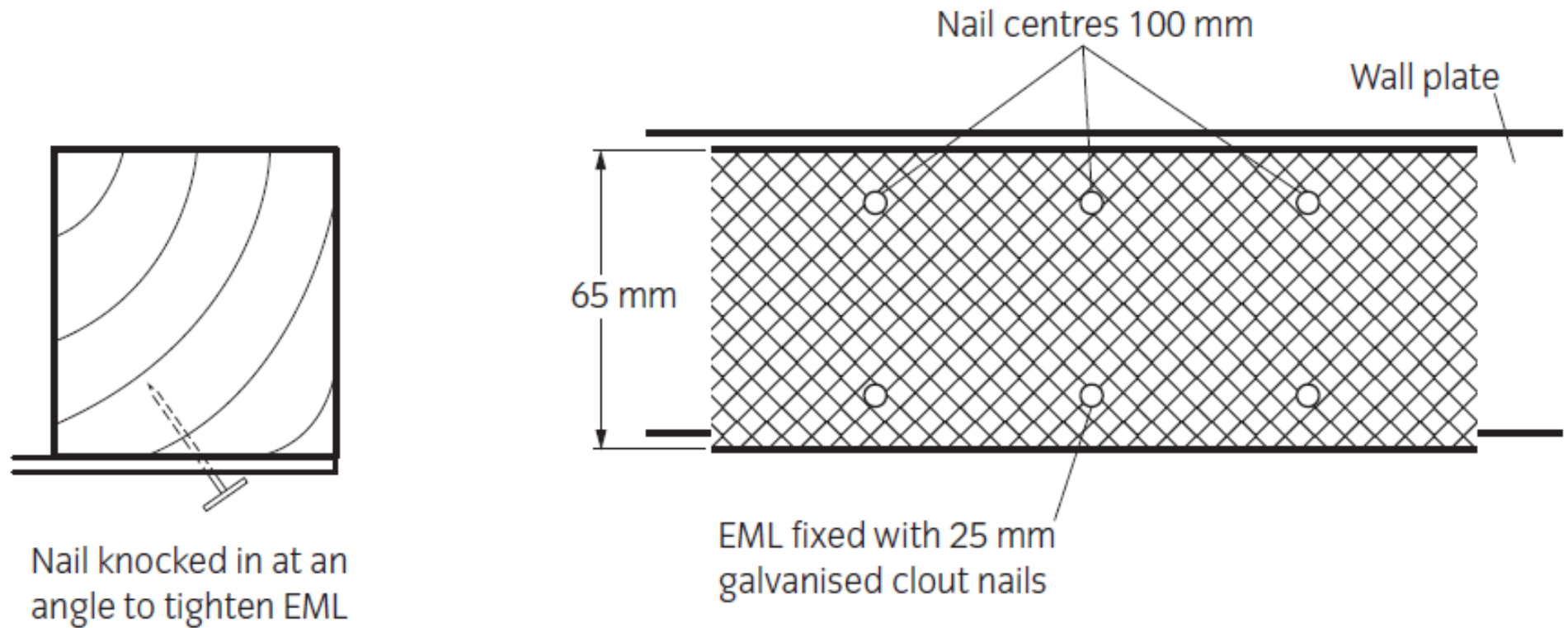

## Drawings and diagrams

### Unit 221 Apply Plastering Materials to Interiors

#### Task 1 Apply plastering material to interiors

Figure 3: Sectioned front view of three coat plasterwork to window and attached pier

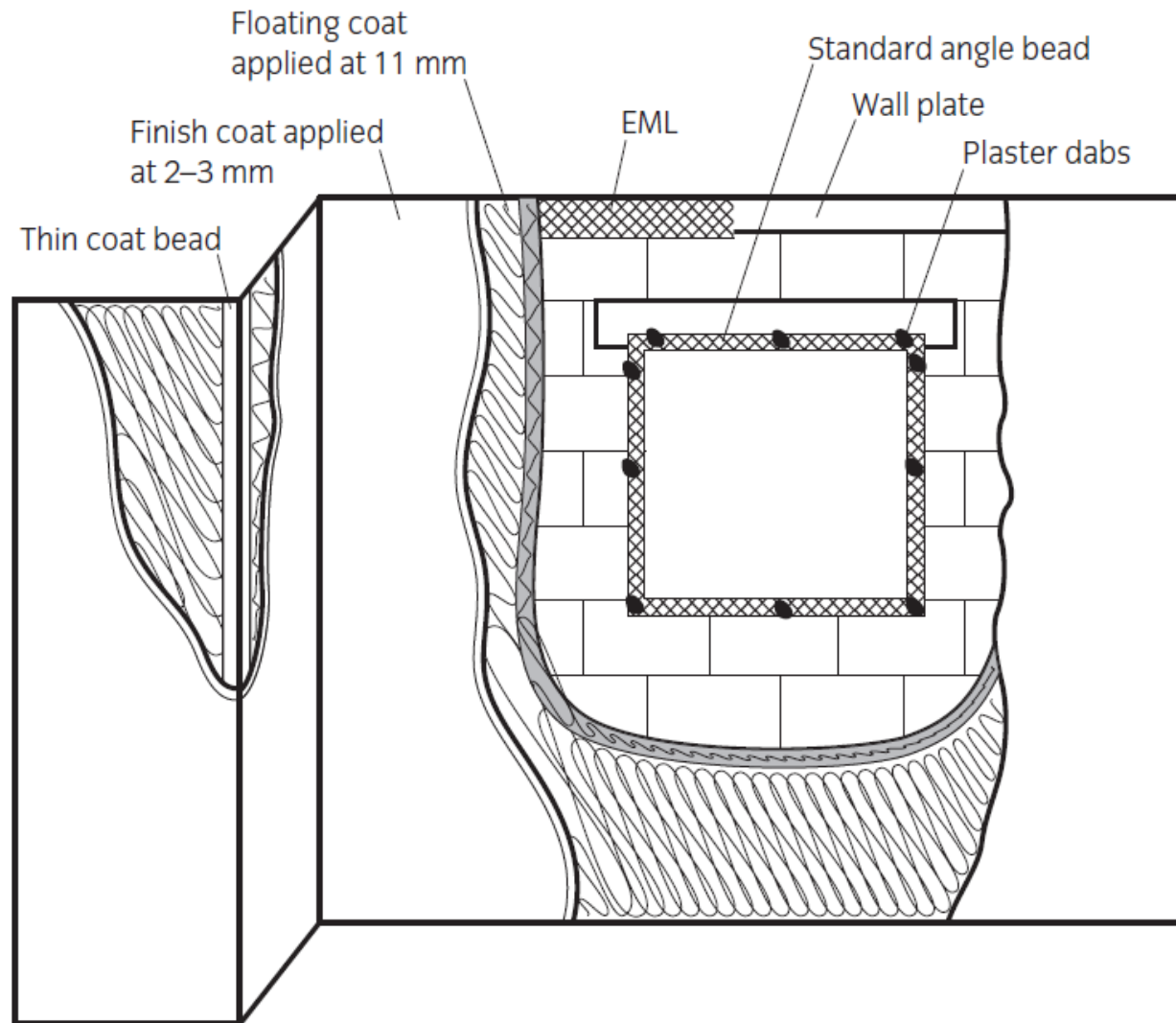



## Drawings and diagrams

### Unit 222 Fix Dry Lining and Plasterboards to Interiors

#### Task 1 Apply dry lining to an interior window wall

Figure 1: Applied direct bond to window wall

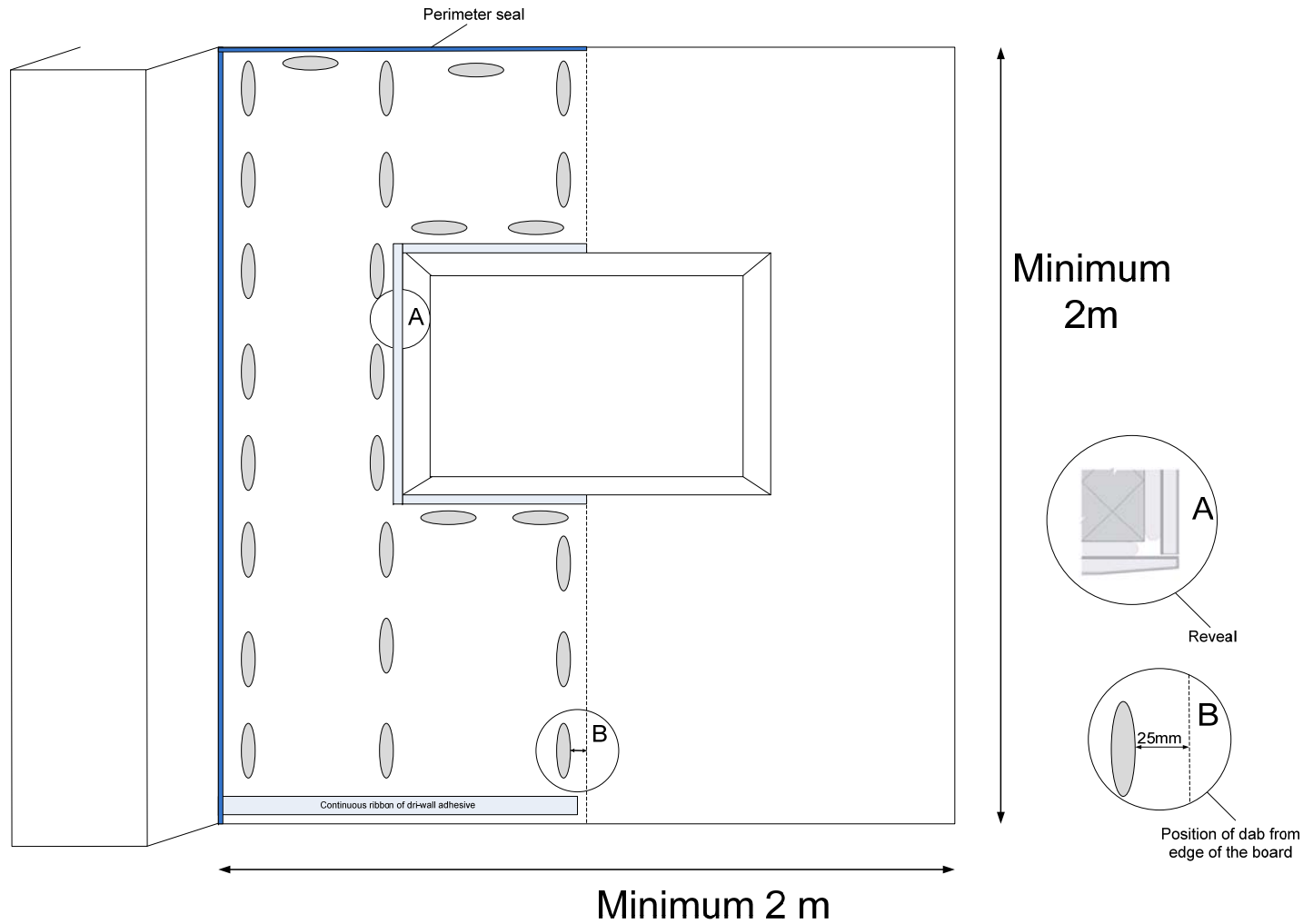

#### Specification

2400 mm x 1200 mm x 12.5 mm tapered edge plasterboard

Drywall adhesive

Paper tape / reinforced tape or thin coat bead

Jointing compound

## Drawings and diagrams

### Unit 222 Fix Dry Lining and Plasterboards to Interiors

#### Task 1 Apply dry lining to an interior window wall

Figure 2: Applied direct bond to window wall

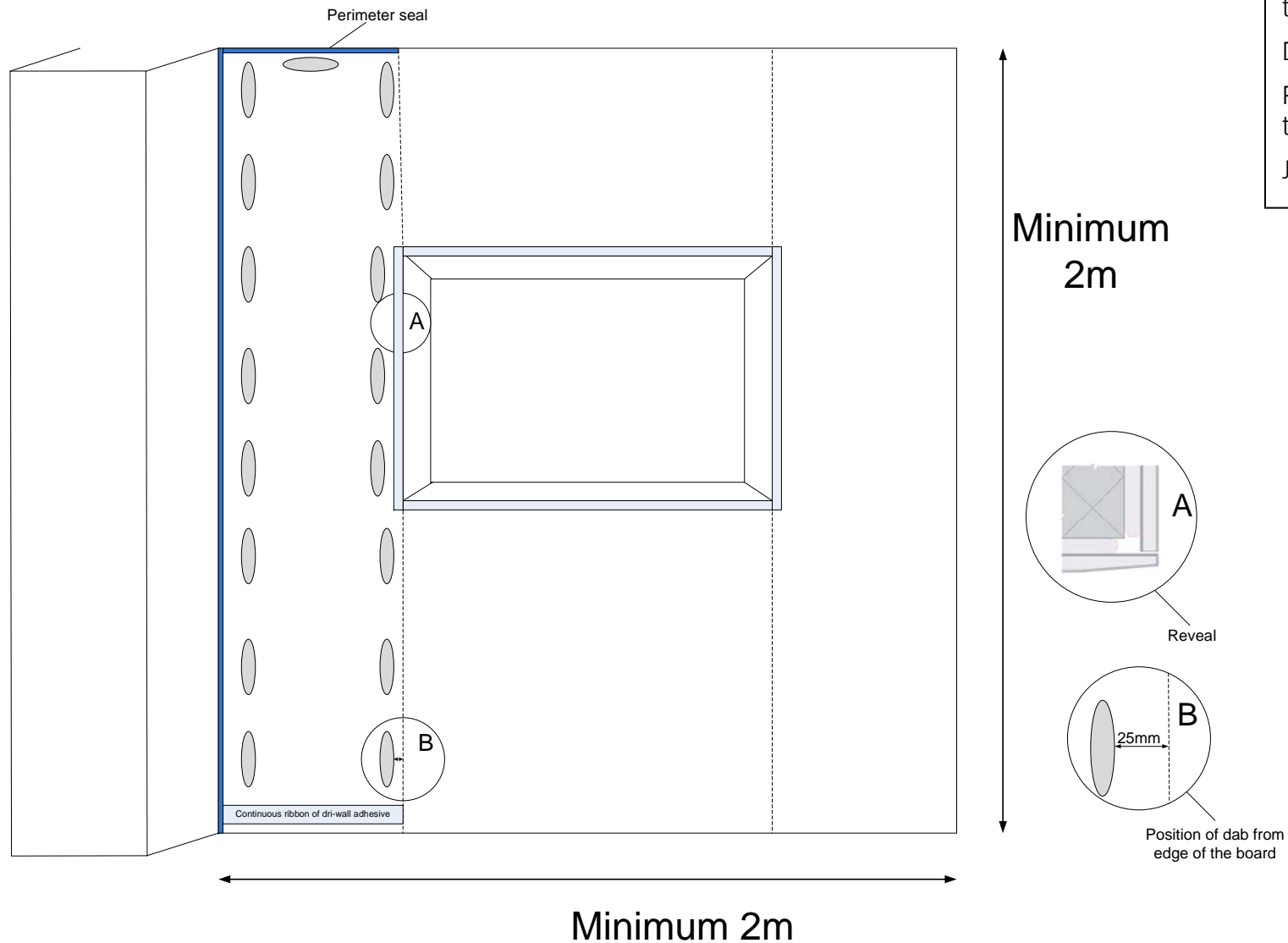

Specification
2400 mm x 1200 mm x 12.5 mm tapered edge plasterboard
Drywall adhesive
Paper tape / reinforced tape or thin coat bead
Jointing compound

## Drawings and diagrams

### Unit 222 Fix Dry Lining and Plasterboards to Interiors Task 2 Fix plasterboards to a ceiling and a stud wall

Figure 1: Before: ceiling joist position

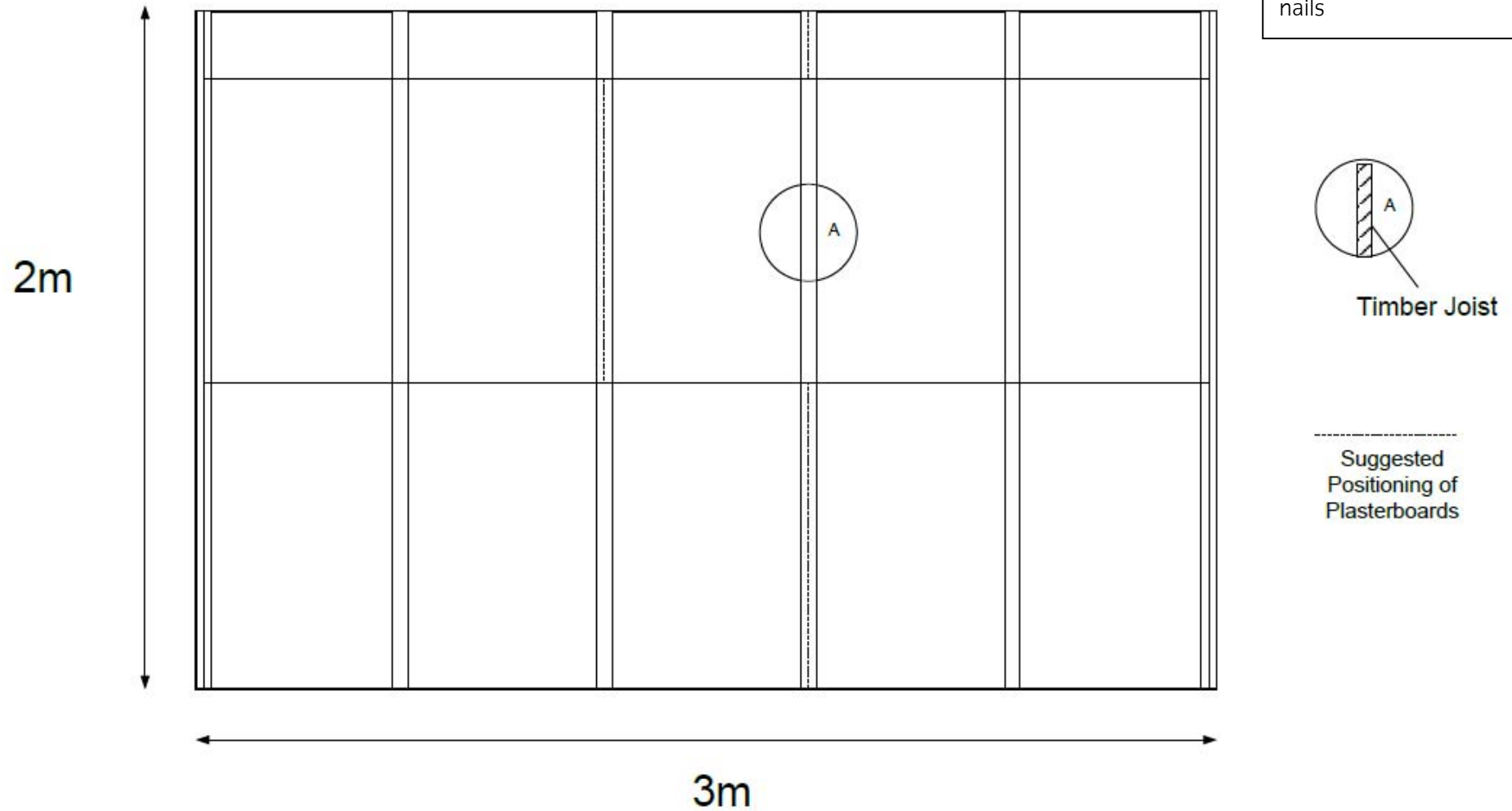

#### Specification

Square edge plasterboard  
1800mm x 900mm

Fixings can be screws or  
nails

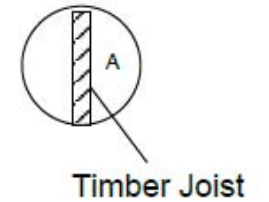

-----  
Suggested  
Positioning of  
Plasterboards

## Drawings and diagrams

### Unit 222 Fix Dry Lining and Plasterboards to Interiors

#### Task 2 Fix plasterboards to a ceiling and a stud wall

Figure 2: After: ceiling joists with fixed plasterboards

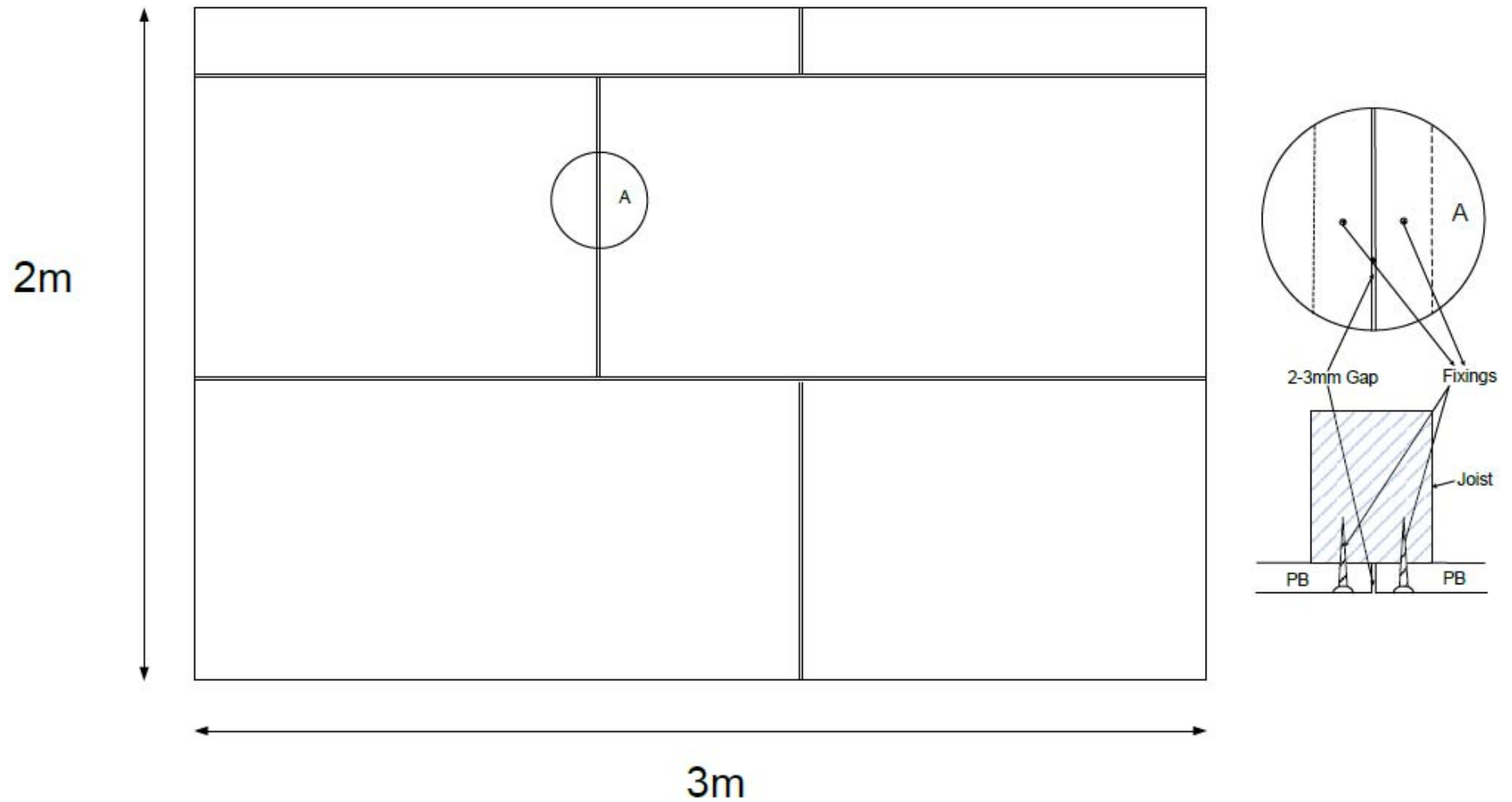

## Drawings and diagrams

### Unit 222 Fix Dry Lining and Plasterboards to Interiors

#### Task 2 Fix plasterboards to a ceiling and a stud wall

Figure 3: Before: timber stud partition

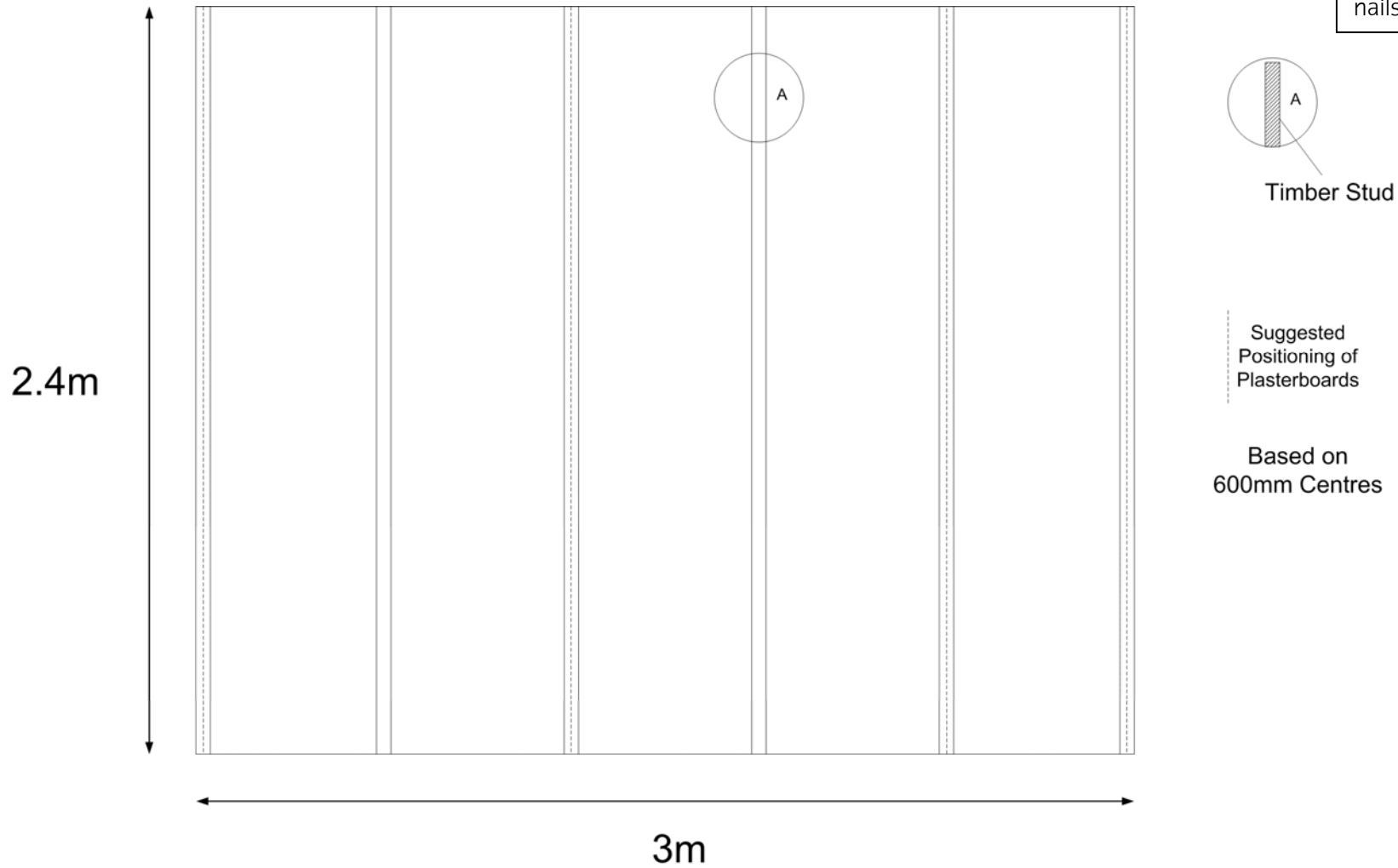

#### Specification

Square edge plasterboard  
2400mm x 1200mm

Fixings can be screws or  
nails

## Drawings and diagrams

### Unit 222 Fix Dry Lining and Plasterboards to Interiors

#### Task 2 Fix plasterboards to a ceiling and a stud wall

Figure 4: After: timber stud partition with fixed plasterboards

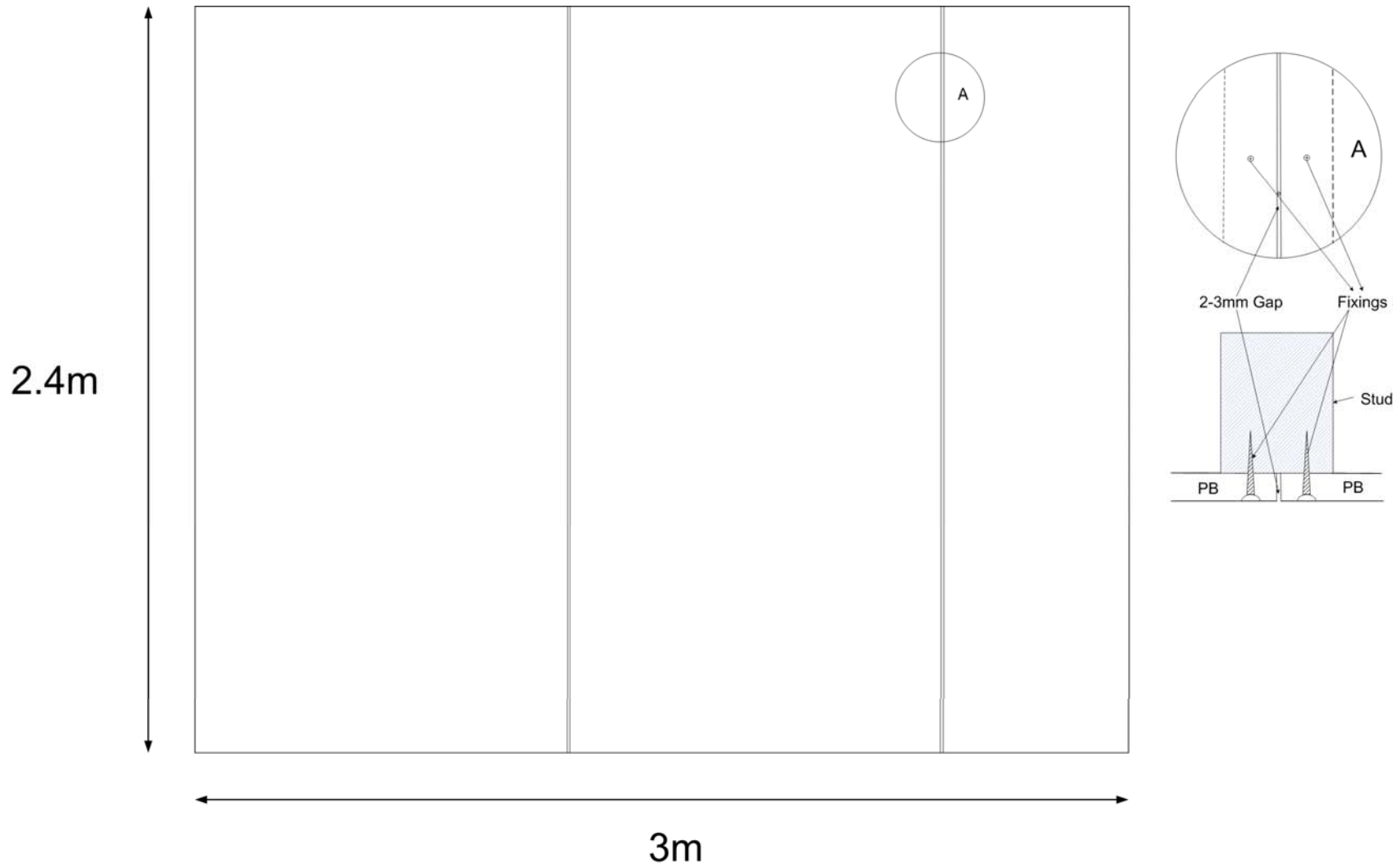

## Drawings and diagrams

### Unit 223 Laying Sand and Cement Screeds

#### Task 1 Lay a floorscreed

Figure 1: Specification for sand and cement floorscreed

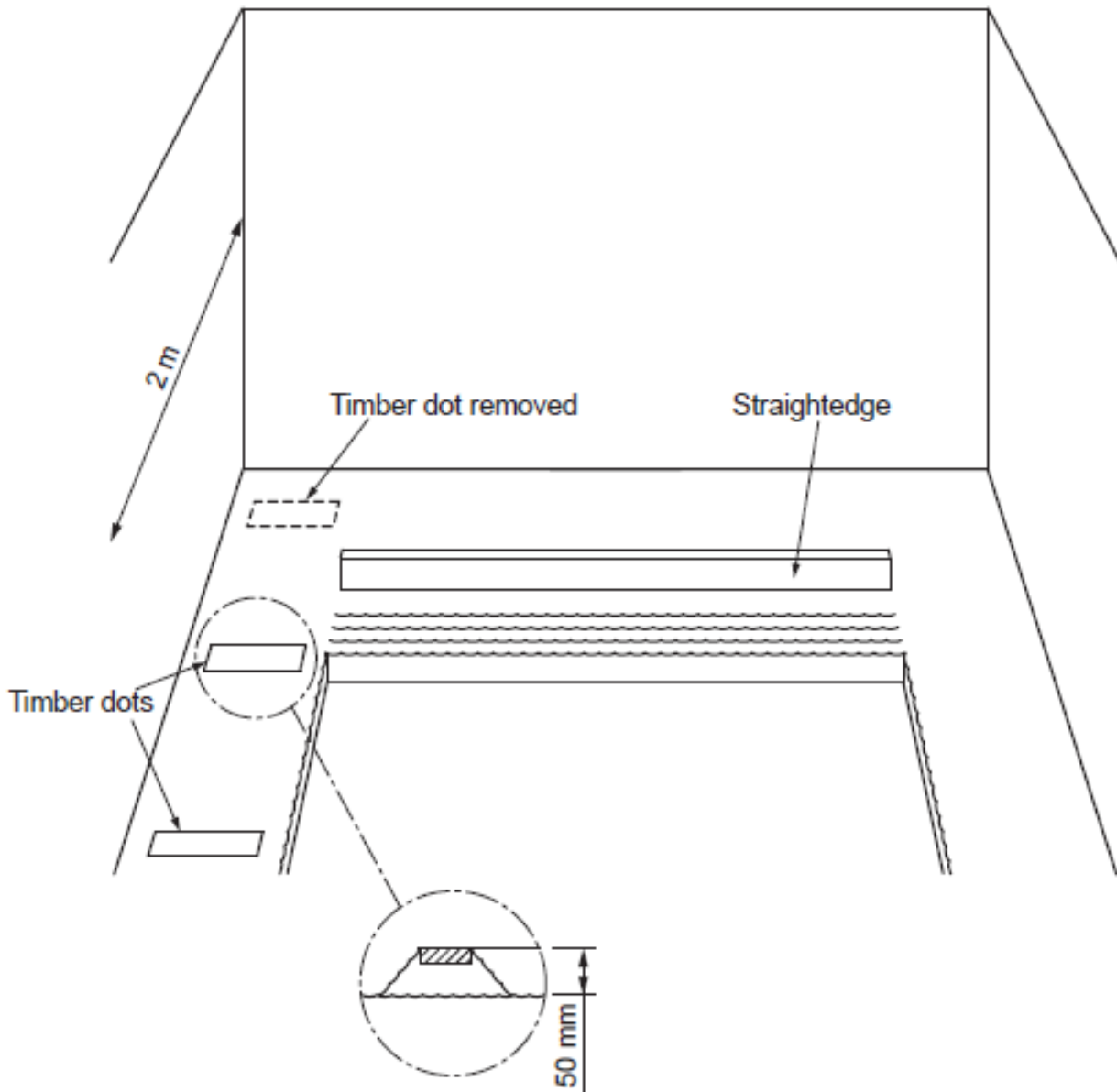

#### Specification

Lay a floorscreed to minimum 5 m<sup>2</sup>.

Mix ratio: 3 parts sand and 1 part cement (or lime). Mix consistency is semi-dry.

Timber battens 25 mm x 50 mm x 450 mm.

Floorscreed should be a minimum uniform thickness of 40-60 mm compacted and consolidated to a smooth closed face finish.

## Drawings and diagrams

### Unit 223 Laying Sand and Cement Screeds

#### Task 2 Lay a floorscreed to falls

Figure 1: Specification for sand and cement floorscreed to falls

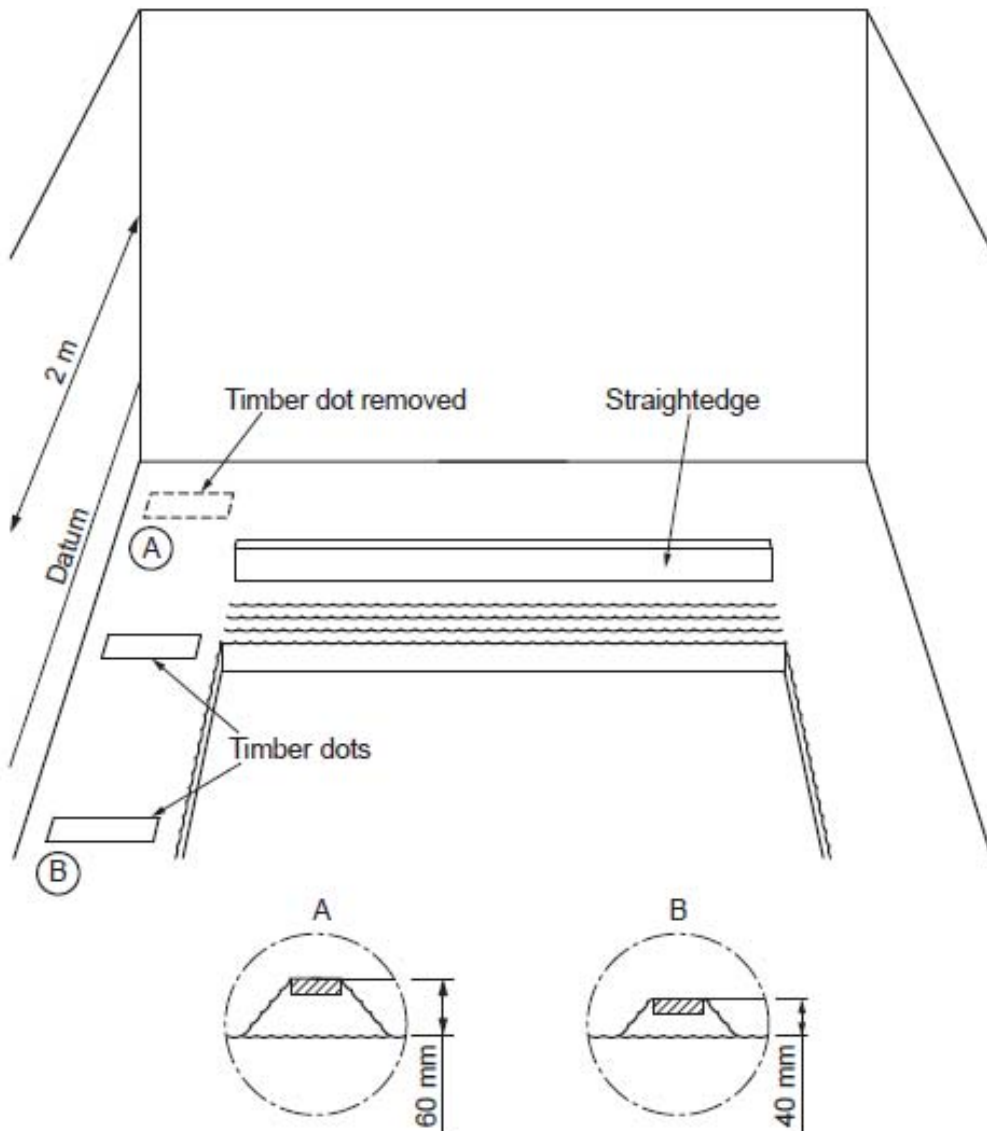

#### Specification

Lay a floorscreed to minimum 5 m<sup>2</sup> with a fall of 20 mm.

Mix ratio: 3 parts sand and 1 part cement (or lime). Mix consistency is semi-dry.

Timber Battens 25 mm x 50 mm x 450 mm.

Floorscreed should be a minimum uniform thickness of 40-60 mm compacted and consolidated to a smooth closed face finish.



## Drawings and diagrams

### Unit 224 Applying Plastering Materials to External Backgrounds

#### Task 1 Apply two coat rendering to external backgrounds

Figure 1: External rendering specification

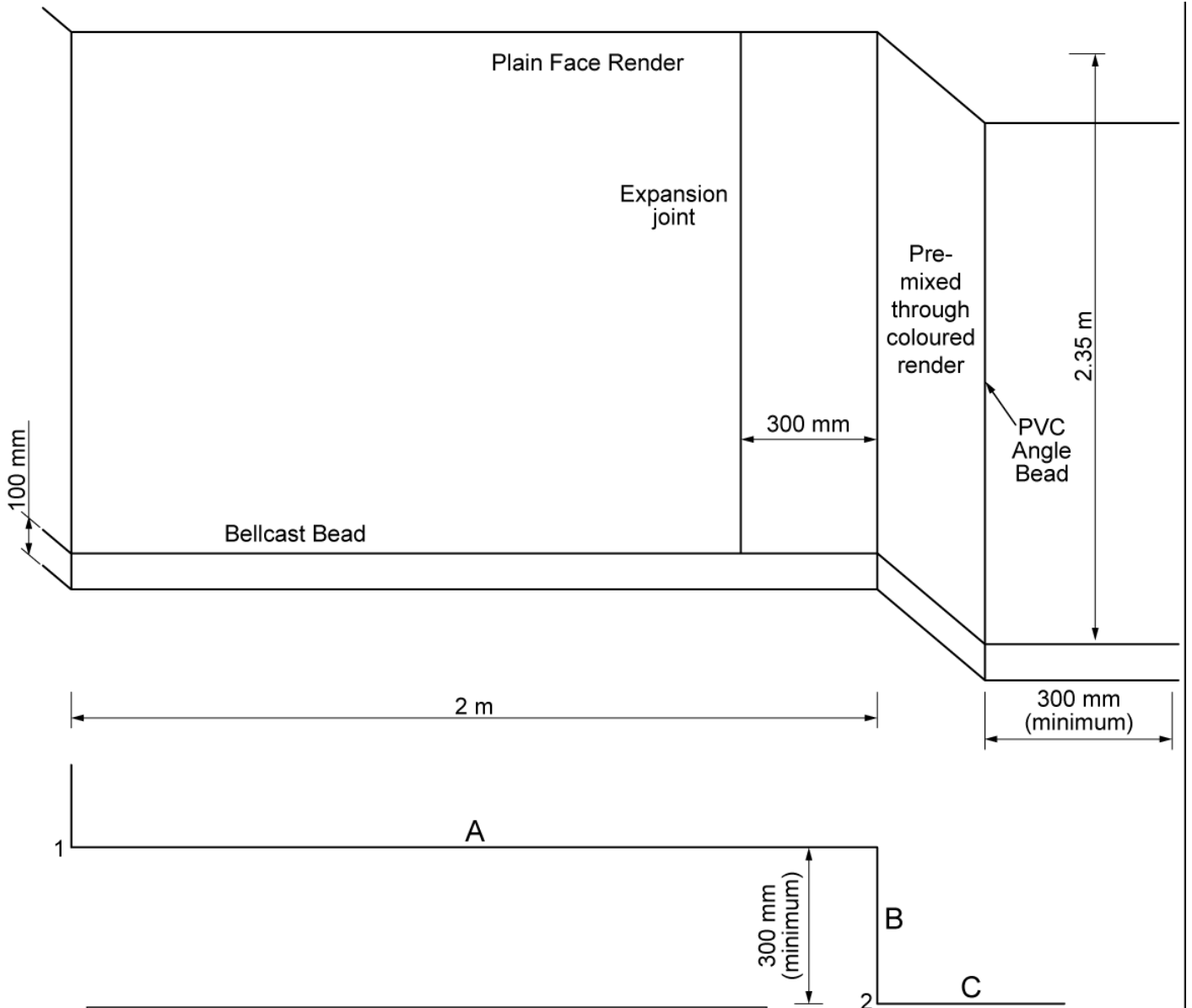

#### Specification

- Area A - Plain face render to include an expansion joint
- Area B - Pre-mixed through coloured render
- Area C - Pre-mixed through coloured render
- Angle 1 - Formed Using Reverse Rule Method
- Angle 2 - PVC Angle Bead
- Galvanised expansion or plaster stop beads and render stop beads. Suitable materials to achieve plain face render and scratch render finishes.

## Drawings and diagrams

### Unit 225 Produce Reverse Moulds for Fibrous Work

#### Task 1 Prepare for and produce a running mould

Figure 1: Specification for constructing the running mould (profile of cornice)

Specification
Zinc/aluminium plate
Panel pins
Timber for running mould
Countersunk screws
Shellac
Profile to be taken from drawing
Timber slipper to be 1.5 X bigger than the stock

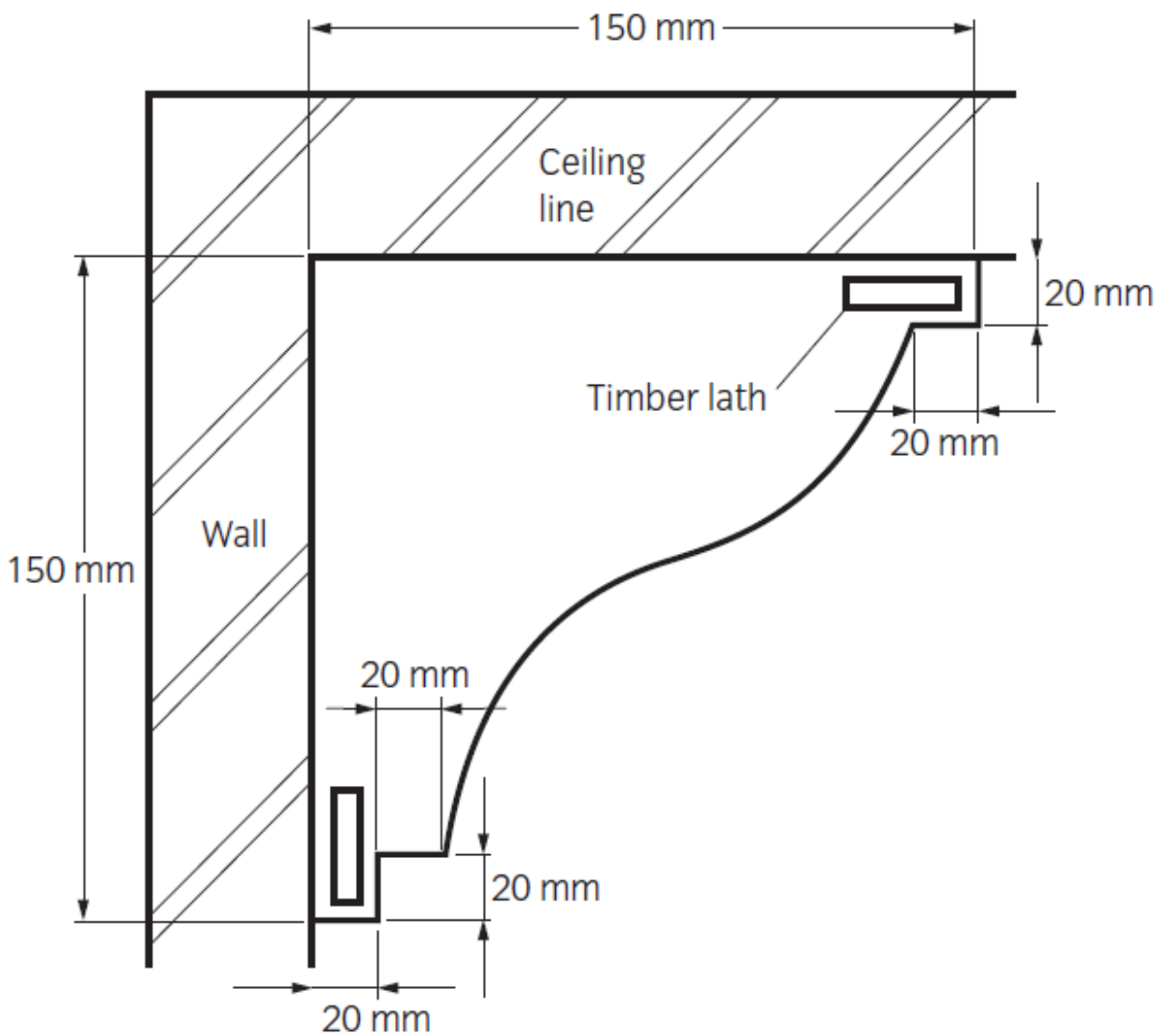

NOT TO SCALE

## Drawings and diagrams

### Unit 225 Produce Reverse Moulds for Fibrous Work

#### Task 1 Prepare for and produce a running mould

Figure 2: Reverse running mould

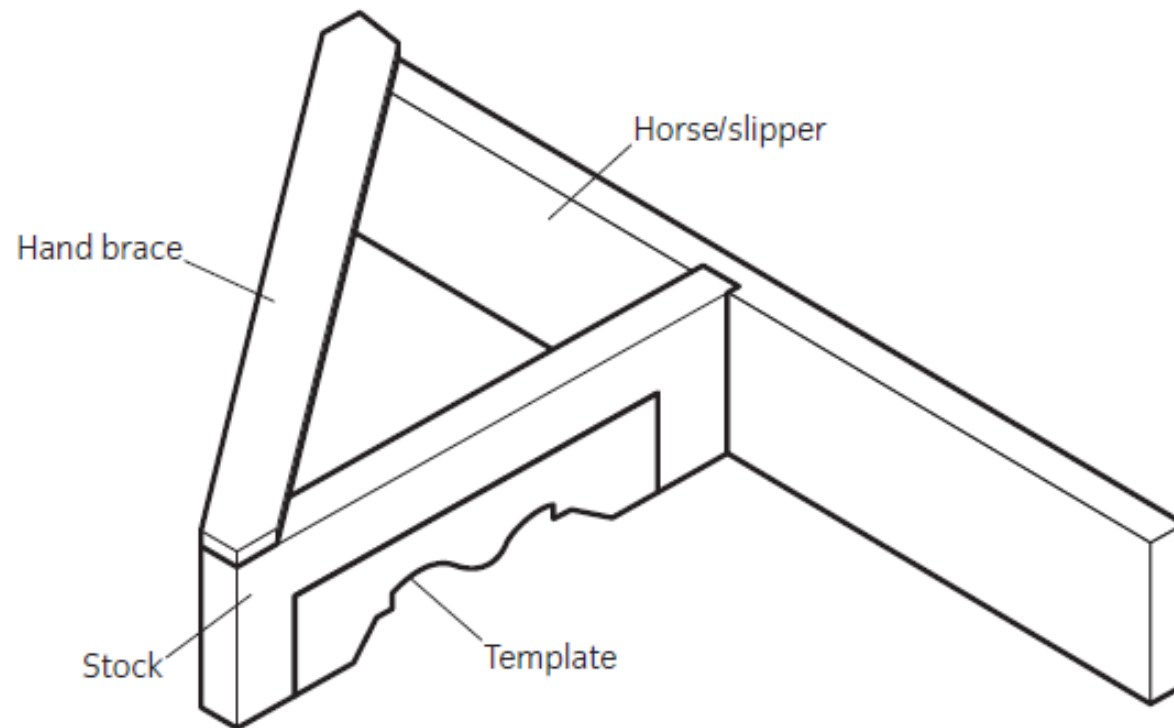

**FOR ILLUSTRATION PURPOSES ONLY**

## Drawings and diagrams

### Unit 225 Produce Reverse Moulds for Fibrous Work

#### Task 2 Produce a reverse mould

Figure 1: Specification to produce the reverse mould (profile of cornice)

Specification
Running bench
Running rule
Tallow or suitable release agent
Class A casting plaster
Suitable core materials
Shellac

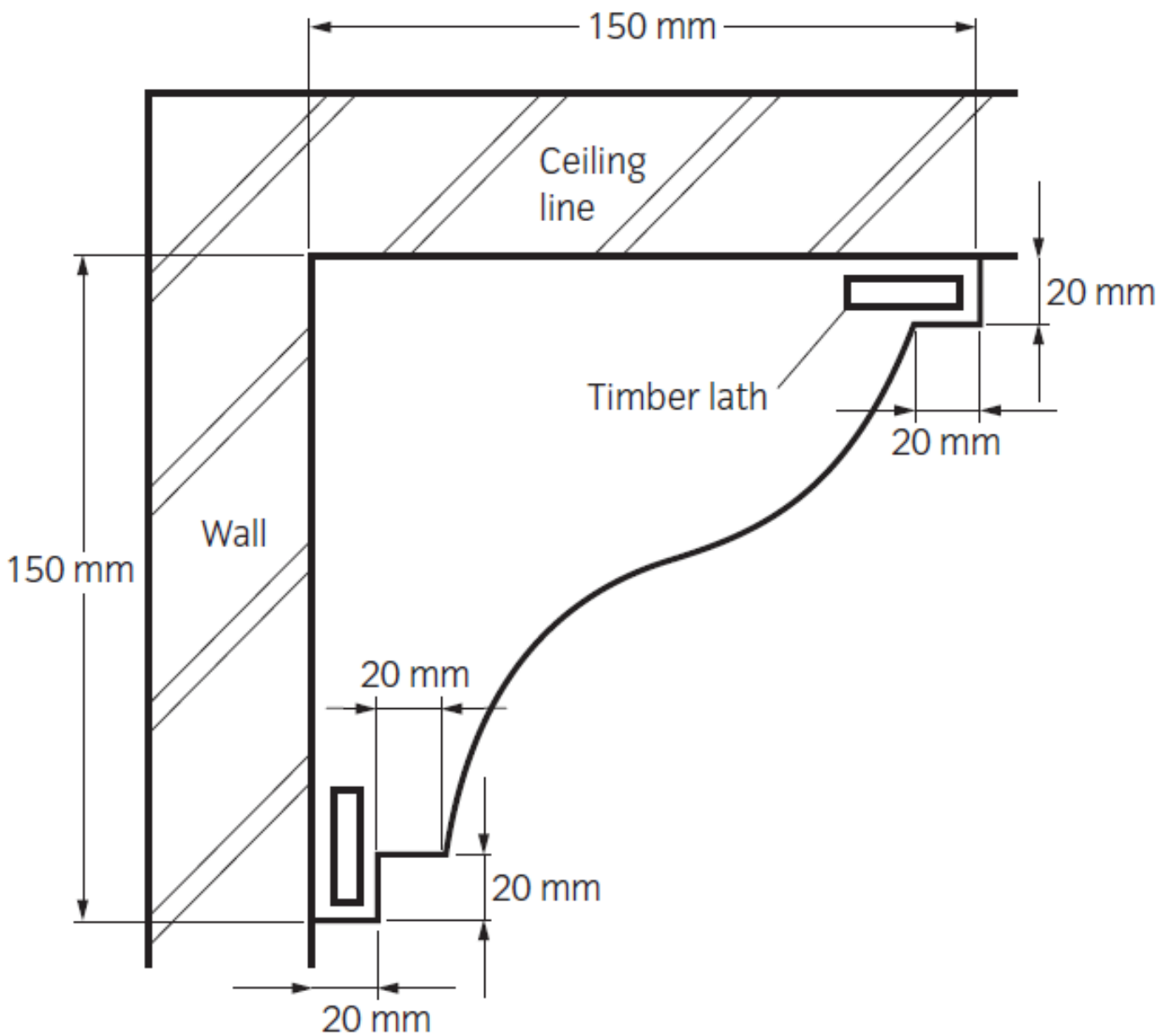

NOT TO SCALE

## Drawings and diagrams

### Unit 226 Casting and Fixing Fibrous Plasterwork Tasks 1 & 2 Prepare to cast and fix fibrous plasterwork Fix and finish fibrous plasterwork

Figure 1: Profile of cornice

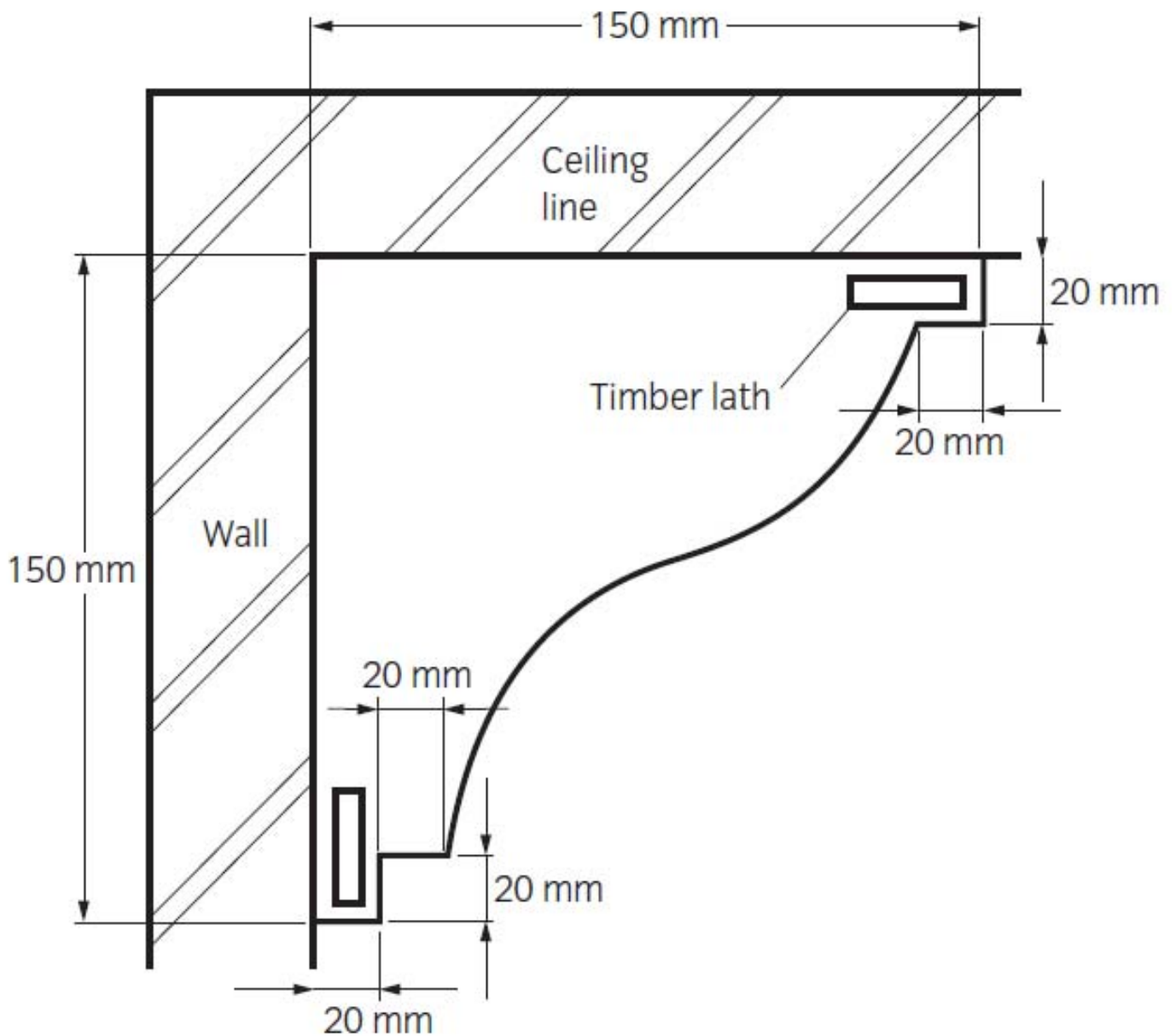

**NOT TO SCALE**

## Drawings and diagrams

### Unit 226 Casting and Fixing Fibrous Plasterwork

#### Tasks 1 & 2 Prepare to cast and fix fibrous plasterwork

#### Fix and finish fibrous plasterwork

Figure 2: Specification for casting

Specification
3 x 1.5 metre lengths of cornice
Reinforcing canvas
Laths

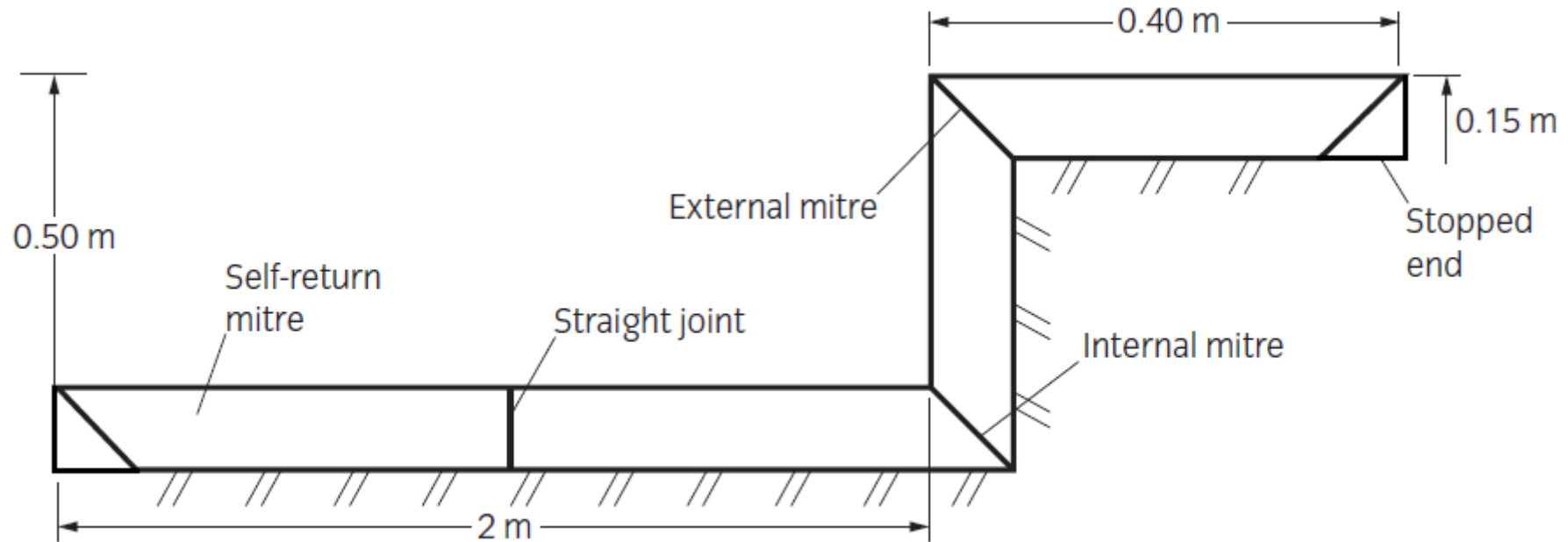

---

**Published by City & Guilds**  
**1 Giltspur Street**  
**London**  
**EC1A 9DD**  
**T +44 (0)844 543 0000**  
**F +44 (0)20 7294 2413**  
**www.cityandguilds.com**

**City & Guilds is a registered charity  
established to promote education  
and training**

#### **About City & Guilds**

As the UK's leading vocational education organisation, City & Guilds is leading the talent revolution by inspiring people to unlock their potential and develop their skills. We offer over 500 qualifications across 28 industries through 8500 centres worldwide and award around two million certificates every year. City & Guilds is recognised and respected by employers across the world as a sign of quality and exceptional training.

#### **City & Guilds Group**

The City & Guilds Group operates from three major hubs: London (servicing Europe, the Caribbean and Americas), Johannesburg (servicing Africa), and Singapore (servicing Asia, Australia and New Zealand). The Group also includes the Institute of Leadership & Management (management and leadership qualifications), City & Guilds Land Based Services (land-based qualifications), the Centre for Skills Development (CSD works to improve the policy and practice of vocational education and training worldwide) and Learning Assistant (an online e-portfolio).

#### **Copyright**

The content of this document is, unless otherwise indicated, © The City and Guilds of London Institute and may not be copied, reproduced or distributed without prior written consent. However, approved City & Guilds centres and candidates studying for City & Guilds qualifications may photocopy this document free of charge and/or include a PDF version of it on centre intranets on the following conditions:

- centre staff may copy the material only for the purpose of teaching candidates working towards a City & Guilds qualification, or for internal administration purposes
- candidates may copy the material only for their own use when working towards a City & Guilds qualification

The *Standard Copying Conditions* (see the City & Guilds website) also apply.

Published by City & Guilds, a registered charity established to promote education and training

Every effort has been made to ensure that the information contained in this publication is true and correct at the time of going to press. However, City & Guilds' products and services are subject to continuous development and improvement and the right is reserved to change products and services from time to time. City & Guilds cannot accept liability for loss or damage arising from the use of information in this publication.