

6806-27 Diploma in Shopfitting Joinery at SCQF Level 5

September 2014 Version 1.0

Contents

Candidate details	1
Unit assessment overview	2
Practical task completion record	2
Instructions to candidates	4
Unit 211 Set up and operate a circular saw	5
Task 1 Change circular saw blades and cut timber and manufactured boards	5
Unit 240 Manufacture internal shopfitting joinery products	7
Task 1 Set out a display stand	7
Task 2 Manufacture, assemble and finish a display stand	8
Unit 241 Manufacture external shopfitting joinery products	11
Task 1 Set out a shopfront	11
Task 2 Manufacture, assemble and finish a shopfront	13
Drawings and diagrams	16
Unit 211 Set up and operate a circular saw	16
Unit 240 Manufacture internal shopfitting joinery products	20
Unit 241 Manufacture external shopfitting joinery products	22

Candidate details



This *Practical task manual* is a record of your achievement in practical assessments. You must keep it in good condition and it must be stored in a safe place by your Assessor.

Please fill in all of your details before you carry out any assessments.

Candidate Details

Surname		Forename(s)	
---------	--	-------------	--

City & Guilds enrolment number	
--------------------------------	--

Centre Details

Name		Centre No	
------	--	-----------	--

I understand the requirements of the qualification and that all the work towards the assessments must be my own.

Candidate signature (please print)	
--	--

Assessor name (please print)		Signed	
--	--	--------	--

Date	
------	--

Unit assessment overview

Practical task completion record

To be completed by Assessor:

All tasks must be passed for the unit to be achieved.

Unit 211 Set up and operate a circular saw

Task	Grade for task
1 Change circular saw blades and cut timber and manufactured boards	P / X
End of unit knowledge test	P / X

Assessor signature and date:

Candidates must pass the task, and the end of unit knowledge test, for this unit to achieve a pass grade overall.

Overall grade

Unit 240 Manufacture internal shopfitting joinery products

Task	Grade for task
1 Set out a display stand	P / X
2 Manufacture, assemble and finish a display stand	P / M / D / X
End of unit knowledge test	P / X

Assessor signature and date:

The overall grade will be the same as the single graded task in this unit.

Overall grade

Unit 241 Manufacture external shopfitting joinery products

Task	Grade for task
1 Set out a shopfront	P / X
2 Manufacture, assemble and finish a shopfront	P / M / D / X
End of unit knowledge test	P / X

Assessor signature and date:

The overall grade will be the same as the single graded task in this unit.

Overall grade

Authenticity and IQA/QC sampling

The assessor's signature on individual tasks will be taken as assurance that the judgements recorded are made on authentic candidate work produced under appropriate conditions. Please complete the declaration below to confirm this is the case.

I confirm that all tasks were conducted under conditions designed to assure the authenticity of the candidate's work, and am satisfied that, to the best of my knowledge, the work assessed was solely that of the candidate.

I have judged all assessments against the relevant assessment and grading criteria and award the candidate the unit grades as calculated above.

Assessor signature	Date
*IQA signature and date	*QC signature and date

*IQA and QC signatures attest to the evidence available on the recorded date(s).

Instructions to candidates

About this document

This *Practical task manual* contains all of the practical assessment for the 6806-27 Diploma in Shopfitting Joinery at SCQF Level 5.

Practical tasks

These tasks let you show your practical skills and are usually graded pass, merit or distinction – a few are pass only. These tasks will be assessed by your assessor watching how you carry out the tasks and checking your final pieces of work.

Before you carry out the task you will be told how it will be assessed and you should read the observation checklist at the end of each task so you know what you need to do to get each grade.

You can ask your assessor for help in understanding the task instructions, but all of the work must be your own.

Health and safety

You must use safe working practices at all times.

You are responsible for your own safety and the safety of others. If you behave in an unsafe way, you will be stopped and given a warning. If you do not meet all of the Health and Safety requirements, the assessment will be stopped. Your assessor will not be able to let you try the task again until they are sure you can work safely.

Time considerations

Each task shows how long it is likely to take. This is for guidance and so you can plan your work. If you have a good reason for needing more time you must explain this to your assessor as soon as possible so they can decide whether you can have more time.

Security

Where an assignment is taken over more than one session, all documentation, paperwork and work products must be labelled carefully with your name and kept securely at the centre. Your assessor will give you directions about how to leave your work.

Opportunities to repeat tasks

The tasks are 'end tests' so you will only be asked to take the assessment when you have had the chance to do all of the learning and practice you need. You will be able to try the whole task again if you do not pass, but you will not be able to take the assessment again just to try to get a better grade.

Feedback

As well as telling you the result for the task, your assessor will give you feedback. They will give you a feedback sheet with details of what you could do to improve, and also what you did well. This will help you to prepare for other assessments or to retake the assessment if you need to.

Unit 211 Set up and operate a circular saw

Task 1 Change circular saw blades and cut timber and manufactured boards

Task coversheet

Expected time	3 hours
Task instructions	<ul style="list-style-type: none"> • Complete a risk assessment • Change the blade on a circular saw. • Set up a circular saw ready for use. • Rip a section of timber with a circular saw as shown in Figures 1 and 2. • Cut board material as shown in Figure 4
Diagrams	Figure 1 Rip cuts page 16 Figure 2 Rip cuts measurement detail page 17 Figure 3 45° rip cut saddle 18 Figure 4 Tapered cut page 19

Observation checklist

AC	The candidate has	Pass	Merit	Distinction
3.1 6.1	completed the risk assessment form accurately, to meet current health and safety legislation	<input type="checkbox"/>		
3.2 3.3 3.4 6.2	followed the sequence for changing circular saw blades using manufacturers' tools in accordance with their instructions and current legislation	<input type="checkbox"/>		
	<ul style="list-style-type: none"> • isolated machine before proceeding 			
	<ul style="list-style-type: none"> • removed guarding, riving knife and saw blade safely and without damage 	<input type="checkbox"/>		
	<ul style="list-style-type: none"> • cleaned machine down 	<input type="checkbox"/>		
	<ul style="list-style-type: none"> • checked replacement blade prior to fitting for correct type and sharpness 	<input type="checkbox"/>		
	<ul style="list-style-type: none"> • saw blade seating and cutting direction correct 	<input type="checkbox"/>		
	<ul style="list-style-type: none"> • tightened blade in accordance with manufacturer's instructions 	<input type="checkbox"/>		
	<ul style="list-style-type: none"> • set riving knife as per current legislation (ACoP) 	<input type="checkbox"/>		
	<ul style="list-style-type: none"> • replaced guarding/ancillary components 	<input type="checkbox"/>		
	<ul style="list-style-type: none"> • checked blade for free rotation 	<input type="checkbox"/>		
	<ul style="list-style-type: none"> • checked machine for faults before reconnecting machine 	<input type="checkbox"/>		
6.4	set guards according to current legislation (ACoP)	<input type="checkbox"/>		

AC	The candidate has	Pass	Merit	Distinction
6.3 6.5 6.6 6.7	identified timber defects <ul style="list-style-type: none"> timber appropriately fed in relation to any cupping, bowing or dead knots 	<input type="checkbox"/>		
	set fences, adjust saw blades and cut material in accordance with Figures 1-4 timber cut as in Figures 1 and 2 <ul style="list-style-type: none"> sections A and B dimensioned within 1 mm in accordance with Figure 2 	<input type="checkbox"/>		
	<ul style="list-style-type: none"> square timber for sections C and D brought to 45 mm wide within 1 mm 	<input type="checkbox"/>		
	<ul style="list-style-type: none"> sections C and D dimensioned in within 1 mm using saddle, in accordance with Figure 2 	<input type="checkbox"/>		
	<ul style="list-style-type: none"> ensured wedge jig handle is sufficiently long to keep hands at least 300 mm away from blade 	<input type="checkbox"/>		
	<ul style="list-style-type: none"> tapered cut to dimensions within 1 mm in accordance with Figure 4 	<input type="checkbox"/>		
6.8 6.9	followed current environmental and relevant health and safety legislation relating to changing circular saw blades and cutting of timber and manufactured boards. This includes: <ul style="list-style-type: none"> push stick used where required the use of appropriate PPE at all times appropriate extraction used at all times cleaning down of all machines after use 	<input type="checkbox"/>		

Task grading rules		Task grade:
To award a pass : every activity in the checklist must be successfully achieved.		
Assessor	Signature & Date	

Unit 240 Manufacture internal shopfitting joinery products

Task 1 Set out a display stand

Task coversheet

Expected time	4 hours
Task instructions	<ul style="list-style-type: none"> • Complete a risk assessment. • Complete a tools and equipment list. • Set out the rod for a display stand. • Complete a cutting list. • Work according to environmental and health and safety regulations.
Diagrams	Figure 1 Display stand page 20 Figure 2 Section details of display stand page 21

Observation checklist

AC	The candidate has	Pass	Merit	Distinction
2.1	carried out a risk assessment for setting out a display stand	<input type="checkbox"/>		
2.2	completed a tools and equipment list and selected appropriate tools and equipment for setting out a display stand	<input type="checkbox"/>		
2.3	set out a display stand	<input type="checkbox"/>		
	<ul style="list-style-type: none"> • overall height of stand correct within 1 mm 			
	<ul style="list-style-type: none"> • overall width of stand correct within 1 mm 	<input type="checkbox"/>		
	<ul style="list-style-type: none"> • all section sizes correct to within 1 mm 	<input type="checkbox"/>		
	<ul style="list-style-type: none"> • all section profiles correct to within 1 mm 	<input type="checkbox"/>		
	<ul style="list-style-type: none"> • joint proportions and positions shown correctly within 1 mm 	<input type="checkbox"/>		
2.4	correctly completed a cutting list	<input type="checkbox"/>		
2.5	followed current environmental and relevant health and safety regulations in relation to setting out a display stand	<input type="checkbox"/>		

Task grading rules	Task grade:
To award a pass : every activity in the checklist must be successfully achieved.	
Assessor Signature & Date	

Unit 240 Manufacture internal shopfitting joinery products

Task 2 Manufacture, assemble and finish a display stand

Task coversheet

Expected time	18 hours
Task instructions	<ul style="list-style-type: none"> • Complete a risk assessment. • Mark out from the rod. • Manufacture and assemble a display stand. • Clean up stand to receive a clear finish. • Work according to environmental and health and safety regulations.
Diagrams	Figure 1 Display stand page 20 Figure 2 Section details of display stand page 21

Observation checklist

AC	The candidate has	Pass	Merit	Distinction
4.1 6.1	carried out a risk assessment for manufacturing a display stand (note: where a risk assessment has been carried out for a previous task, the same form may be added to for this criteria)	<input type="checkbox"/>		
4.2	selected materials for manufacturing a display stand <ul style="list-style-type: none"> • face and edge correctly selected and marked on all pieces 	<input type="checkbox"/>		
4.3	marked out materials from setting out details <ul style="list-style-type: none"> • mortices and tenons marked out correctly to within 1 mm 	<input type="checkbox"/>		
	<ul style="list-style-type: none"> • tenon shoulders marked out correctly to within 1 mm 	<input type="checkbox"/>		
	<ul style="list-style-type: none"> • sections correctly indicated 	<input type="checkbox"/>		
	<ul style="list-style-type: none"> • lines clean (no double lines) 	<input type="checkbox"/>		
4.4	used tools and machines to profile timber and form joints to manufacture a display stand <ul style="list-style-type: none"> • mortices clean without breakout 	<input type="checkbox"/>		
	<ul style="list-style-type: none"> • no bandsaw overrun 	<input type="checkbox"/>		
	<ul style="list-style-type: none"> • no drop-ins/bumps in mouldings exceeding 1 mm 	<input type="checkbox"/>		
	<ul style="list-style-type: none"> • no drop-ins/bumps in grooves exceeding 1 mm 	<input type="checkbox"/>		
	<ul style="list-style-type: none"> • groove size correct within 1 mm 	<input type="checkbox"/>		

AC	The candidate has	Pass	Merit	Distinction
	<ul style="list-style-type: none"> grooves in legs stopped between mortices 	<input type="checkbox"/>		
6.2	dry fitted to check the joints for tight fit and overall finished size	<input type="checkbox"/>		
6.3	cleaned up the inside face of components	<input type="checkbox"/>		
6.4	assembled with adhesive and cramps <ul style="list-style-type: none"> gaps in shoulders not exceeding 0.5 mm (gaps which exceed 0.5 mm must not exceed 1 mm) 	<input type="checkbox"/> 7 out of 16 joints	<input type="checkbox"/> 10 out of 16 joints	<input type="checkbox"/> 13 out of 16 joints
	<ul style="list-style-type: none"> mortice gaps not exceeding 0.5 mm (gaps which exceed 0.5 mm must not exceed 1 mm) 	<input type="checkbox"/> 3 out of 8 joints	<input type="checkbox"/> 5 out of 8 joints	<input type="checkbox"/> 7 out of 8 joints
	<ul style="list-style-type: none"> no mitre gaps to lippings exceeding 0.5 mm 	<input type="checkbox"/>		
	<ul style="list-style-type: none"> no gap between top panel and lippings exceeding 0.5 mm 	<input type="checkbox"/>		
	<ul style="list-style-type: none"> chamfer and groove dimensions correct within 1 mm 	<input type="checkbox"/>		
	<ul style="list-style-type: none"> laminates securely bonded without visible adhesive 	<input type="checkbox"/>		
	<ul style="list-style-type: none"> without cramp marks 	<input type="checkbox"/>		
	<ul style="list-style-type: none"> top securely fixed with brackets 	<input type="checkbox"/>		
	<ul style="list-style-type: none"> excess glue cleaned off 	<input type="checkbox"/>		
6.5	carried out quality checks <ul style="list-style-type: none"> all four faces square within 2 mm 	<input type="checkbox"/>		
	<ul style="list-style-type: none"> overall height correct 	<input type="checkbox"/> within 3 mm	<input type="checkbox"/> within 2 mm	<input type="checkbox"/> within 1 mm
	<ul style="list-style-type: none"> overall width both ways correct 	<input type="checkbox"/> within 3 mm	<input type="checkbox"/> within 2 mm	<input type="checkbox"/> within 1 mm
	<ul style="list-style-type: none"> no rocking when placed on flat surface 	<input type="checkbox"/> within 2 mm	<input type="checkbox"/> within 1 mm	<input type="checkbox"/> 0 mm
6.6	prepared the display stand to receive finishes <ul style="list-style-type: none"> lippings flushed using smoothing plane, without tram lines and tearing 	<input type="checkbox"/>		
	<ul style="list-style-type: none"> finish to laminate top not damaged or sanded through 	<input type="checkbox"/>		
	<ul style="list-style-type: none"> faces sanded to receive clear finish and arrises removed 	<input type="checkbox"/>		
4.5 6.7	tools kept sharp and stored safely after use	<input type="checkbox"/>		

AC	The candidate has	Pass	Merit	Distinction
4.6 6.8	<p>followed current environmental and relevant health and safety regulations in relation to manufacturing, assembling and finishing a display stand. This includes</p> <ul style="list-style-type: none"> • working in accordance with COSHH, PUWER and ACoP • use of PPE • good house keeping 	<input type="checkbox"/>		

Task grading rules	Task grade:
To award a pass : every activity in the checklist must be successfully achieved.	
To award a merit : in addition to the above, all 5 graded activities in the checklist must be achieved to at least a merit standard.	
To award a distinction : in addition to both of the above, all 5 graded activities in the checklist must be achieved to a distinction standard.	
Assessor Signature & Date	

Unit 241 Manufacture external shopfitting joinery products

Task 1 Set out a shopfront

Task coversheet

Expected time	5 hours
Task instructions	<ul style="list-style-type: none"> • Complete a risk assessment. • Complete a tools and equipment list. • Set out the rod for a shopfront. • Complete a cutting list. • Work according to environmental and health and safety regulations.
Diagrams	Figure 1: Front elevation and section details of shopfront page 22

Observation checklist

AC	The candidate has	Pass	Merit	Distinction
2.1	carried out a risk assessment for setting out a shopfront	<input type="checkbox"/>		
2.2	completed a tools and equipment list and selected appropriate tools and equipment for setting out a shopfront	<input type="checkbox"/>		
2.3	set out a shopfront	<input type="checkbox"/>		
	<ul style="list-style-type: none"> • overall height of entrance correct within 1 mm 	<input type="checkbox"/>		
	<ul style="list-style-type: none"> • overall height of shopfront correct within 1 mm 	<input type="checkbox"/>		
	<ul style="list-style-type: none"> • overall width of shopfront correct within 1 mm 	<input type="checkbox"/>		
	<ul style="list-style-type: none"> • all section sizes correct to within 1 mm 	<input type="checkbox"/>		
	<ul style="list-style-type: none"> • all section profiles correct to within 1 mm 	<input type="checkbox"/>		
	<ul style="list-style-type: none"> • joint proportions and positions shown correctly within 1 mm 	<input type="checkbox"/>		
2.4	correctly completed a cutting list	<input type="checkbox"/>		
2.5	followed current environmental and relevant health and safety regulations in relation to setting out a shopfront	<input type="checkbox"/>		

Task grading rules	Task grade:
To award a pass : every activity in the checklist must be successfully achieved.	
Assessor Signature & Date	

Unit 241 Manufacture external shopfitting joinery products

Task 2 Manufacture, assemble and finish a shopfront

Task coversheet

Expected time	18 hours
Task instructions	<ul style="list-style-type: none"> • Complete a risk assessment. • Mark out from the rod. • Manufacture and assemble a shopfront. • Clean up to receive a clear finish. • Work according to environmental and health and safety regulations.
Diagrams	Figure 1: Front elevation and section details of shopfront page 22

Observation checklist

AC	The candidate has	Pass	Merit	Distinction
4.1 6.1	carried out a risk assessment for manufacturing a shopfront (note: where a risk assessment has been carried out for a previous task, the same form may be added to for this criteria)	<input type="checkbox"/>		
4.2	selected materials for manufacturing a shopfront <ul style="list-style-type: none"> • face and edge correctly selected and marked on all pieces 	<input type="checkbox"/>		
4.3	marked out materials from setting out details <ul style="list-style-type: none"> • mortices and tenons marked out correctly to within 1 mm 	<input type="checkbox"/>		
	<ul style="list-style-type: none"> • tenon shoulders marked out correctly to within 1 mm 	<input type="checkbox"/>		
	<ul style="list-style-type: none"> • sections correctly indicated 	<input type="checkbox"/>		
	<ul style="list-style-type: none"> • lines clean (no double lines) 	<input type="checkbox"/>		
4.4	used tools and machines to profile timber and form joints to manufacture a shopfront <ul style="list-style-type: none"> • mortices clean without breakout 	<input type="checkbox"/>		
	<ul style="list-style-type: none"> • no bandsaw overrun 	<input type="checkbox"/>		
	<ul style="list-style-type: none"> • no drop-ins/bumps in mouldings exceeding 1 mm 	<input type="checkbox"/>		
	<ul style="list-style-type: none"> • no drop-ins/bumps in rebates exceeding 1 mm 	<input type="checkbox"/>		
	<ul style="list-style-type: none"> • rebate sizes correct within 1 mm 	<input type="checkbox"/>		

AC	The candidate has	Pass	Merit	Distinction
	<ul style="list-style-type: none"> through scribes cut with a tenon saw without breakout 	<input type="checkbox"/>		
6.2	dry fitted to check the joints for tight fit and overall finished size	<input type="checkbox"/>		
6.3	cleaned up the inside face of components	<input type="checkbox"/>		
6.4	assembled with adhesive and cramps	<input type="checkbox"/>		
	<ul style="list-style-type: none"> no gaps in shoulders exceeding 1 mm 	<input type="checkbox"/>		
	<ul style="list-style-type: none"> no mortice gaps exceeding 1 mm 	<input type="checkbox"/>		
	<ul style="list-style-type: none"> without cramp marks 	<input type="checkbox"/>		
	<ul style="list-style-type: none"> joints securely screwed 	<input type="checkbox"/>		
	<ul style="list-style-type: none"> pellets to sub-cill and mullion cleaned off flush (not broken off below surface) with grain direction correct 	<input type="checkbox"/>		
	<ul style="list-style-type: none"> sub-cill secured with adhesive with no gaps exceeding 1 mm 	<input type="checkbox"/>		
	<ul style="list-style-type: none"> excess glue cleaned off 	<input type="checkbox"/>		
6.5	carried out quality checks	<input type="checkbox"/>	<input type="checkbox"/>	<input type="checkbox"/>
	<ul style="list-style-type: none"> square 	within 3 mm	within 2 mm	within 1 mm
	<ul style="list-style-type: none"> out of wind within 2 mm 	<input type="checkbox"/>		
	<ul style="list-style-type: none"> overall height correct 	<input type="checkbox"/>	<input type="checkbox"/>	<input type="checkbox"/>
		within 3 mm	within 2 mm	within 1 mm
	<ul style="list-style-type: none"> overall width correct 	<input type="checkbox"/>	<input type="checkbox"/>	<input type="checkbox"/>
		within 3 mm	within 2 mm	within 1 mm
	<ul style="list-style-type: none"> overall height of shop window correct 	<input type="checkbox"/>	<input type="checkbox"/>	<input type="checkbox"/>
		within 3 mm	within 2 mm	within 1 mm
	<ul style="list-style-type: none"> opening width between door frame rebates correct 	<input type="checkbox"/>	<input type="checkbox"/>	<input type="checkbox"/>
		within 3 mm	within 2 mm	within 1 mm
6.6	prepared the shopfront to receive finishes	<input type="checkbox"/>		
	<ul style="list-style-type: none"> joints flushed using smoothing plane, without tram lines and tearing 			
	<ul style="list-style-type: none"> faces sanded to receive clear finish and arrises removed 	<input type="checkbox"/>		
4.5 6.7	tools kept sharp and stored safely after use	<input type="checkbox"/>		
4.5 4.6 6.7 6.8	<p>followed current environmental and relevant health and safety regulations in relation to manufacturing, assembling and finishing a shopfront. This includes</p> <ul style="list-style-type: none"> working in accordance with PUWER and ACoP use of PPE good house keeping 	<input type="checkbox"/>		

Task grading rules	Task grade:
To award a pass : every activity in the checklist must be successfully achieved.	
To award a merit : in addition to the above, all 5 graded activities in the checklist must be achieved to at least a merit standard.	
To award a distinction : in addition to both of the above, all 5 graded activities in the checklist must be achieved to a distinction standard.	
Assessor Signature & Date	

Drawings and diagrams

Unit 211 Set up and operate a circular saw

Task 1 Change circular saw blades and cut timber and manufactured boards

Figure 1 Rip cuts

Diagram not to scale

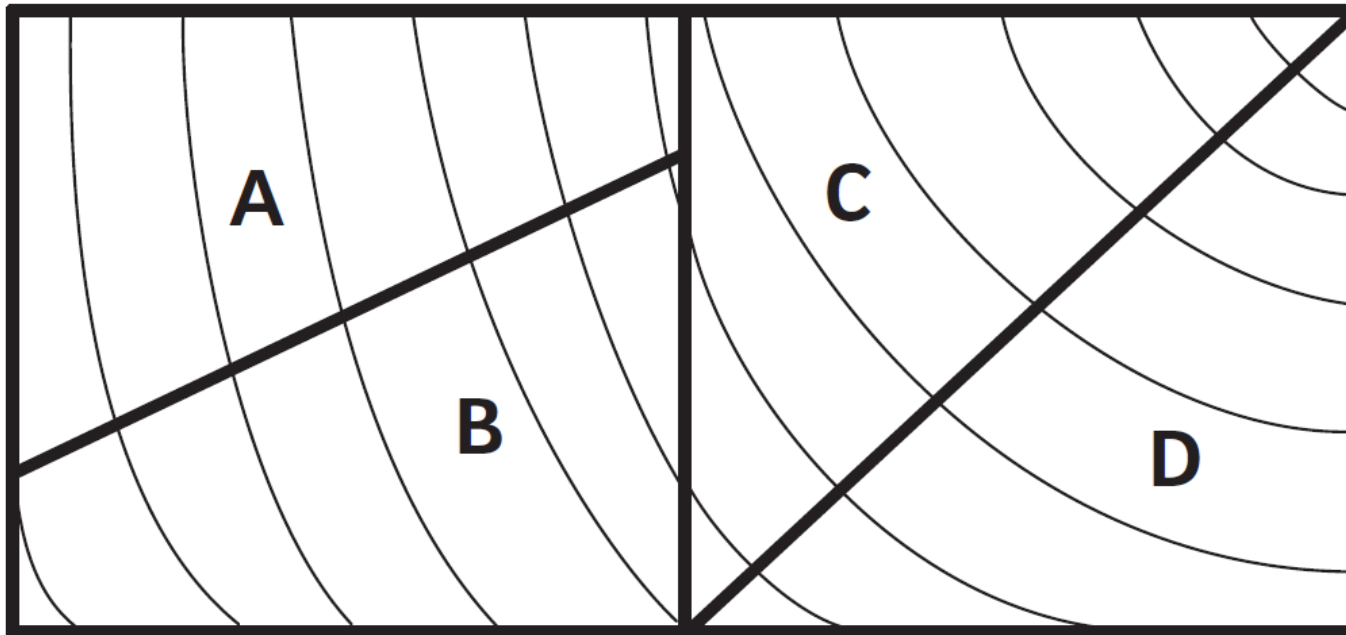

Drawings and diagrams

Unit 211 Set up and operate a circular saw

Task 1 Change circular saw blades and cut timber and manufactured boards

Figure 2 Rip cuts measurement detail

Diagram not to scale

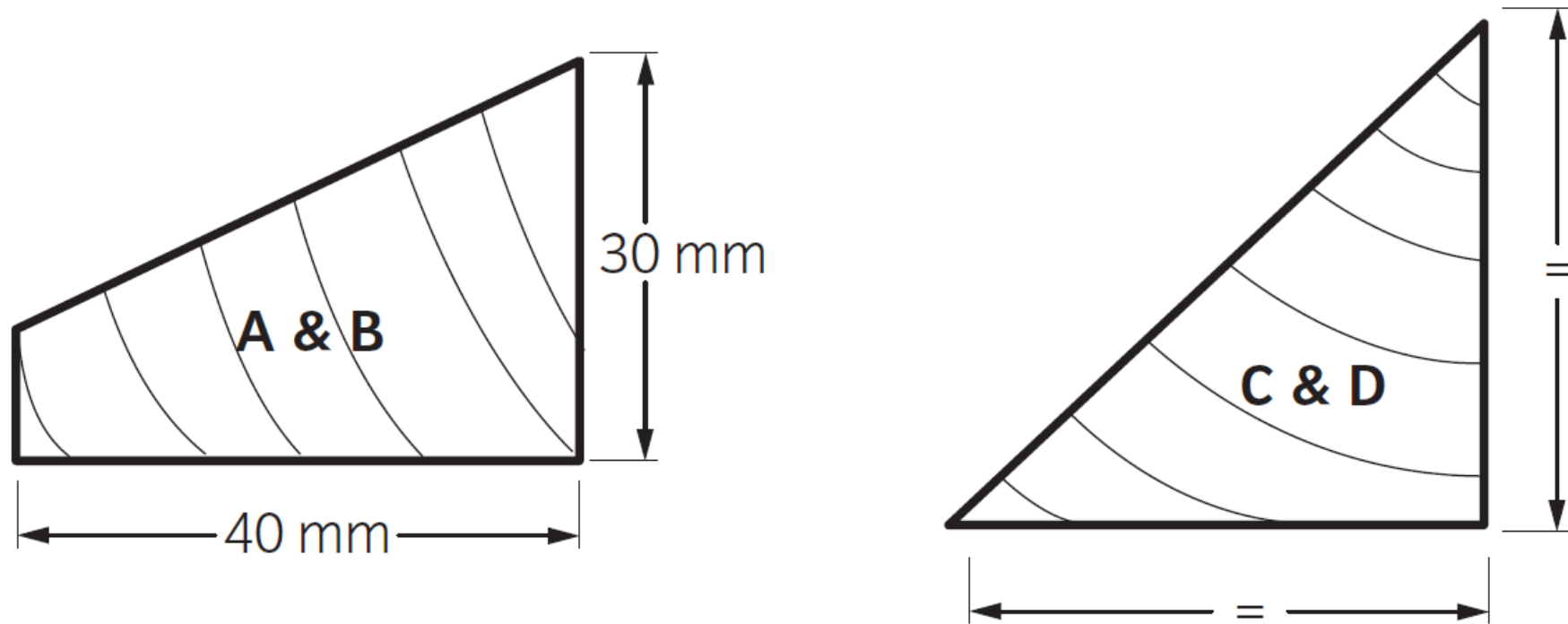

Drawings and diagrams

Unit 211 Set up and operate a circular saw

Task 1 Change circular saw blades and cut timber and manufactured boards

Figure 3 45° rip cut saddle

Diagram not to scale

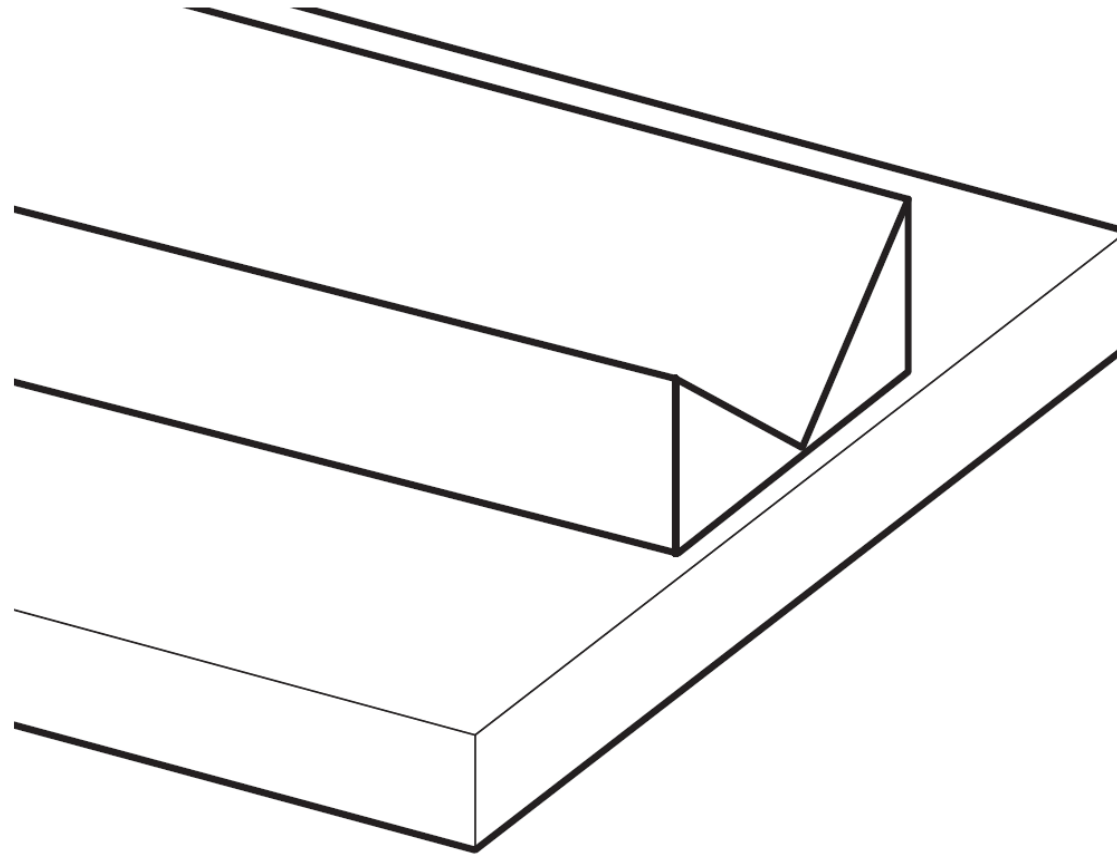

Drawings and diagrams

Unit 211 Set up and operate a circular saw

Task 1 Change circular saw blades and cut timber and manufactured boards

Figure 4 Tapered cut

Diagram not to scale

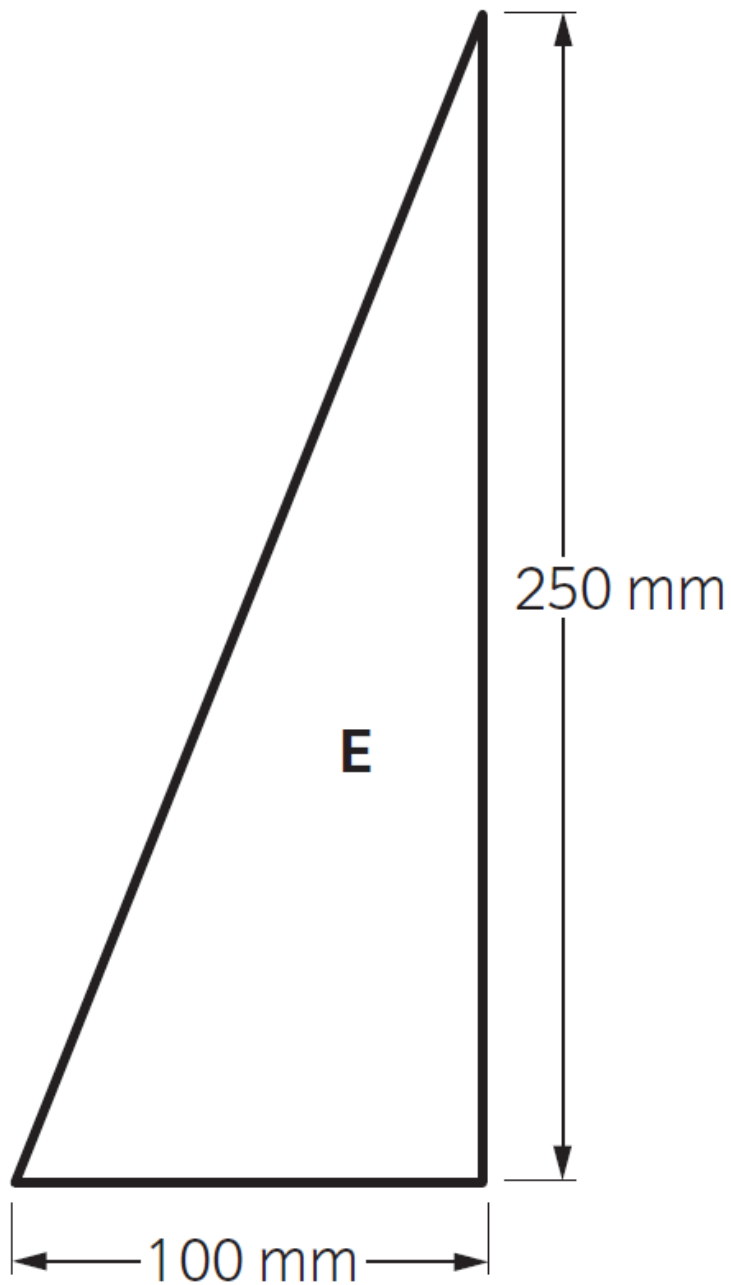

Drawings and diagrams

Unit 240 Manufacture internal shopfitting joinery products

Task 1 Set out a display stand

Task 2 Manufacture, assemble and finish a display stand

Figure 1: Display stand

Specification:
Top: 18 mm melamine faced board
Lipping H/W: 44 x 20
Legs S/W: 45 x 45
Rails S/W: 45 x 22
Panels: 6 mm MDF
6 mm Ply loose tongue or biscuits for jointing (to suit centre requirements)
All measurements shown in mm

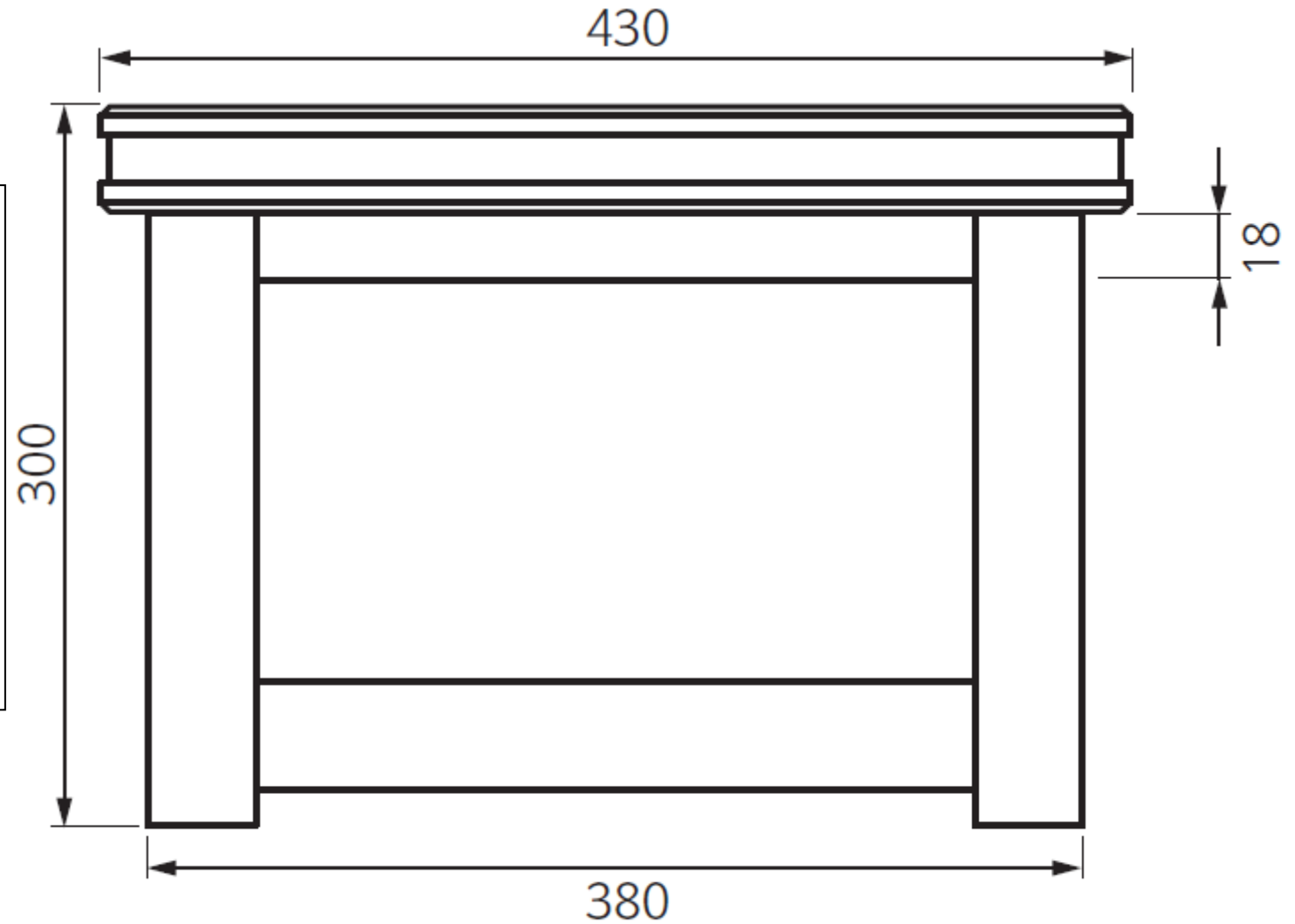

Front elevation

Drawings and diagrams

Unit 240 Manufacture internal shopfitting joinery products

Task 1 Set out a display stand

Task 2 Manufacture, assemble and finish a display stand

Figure 2: Section details of display stand

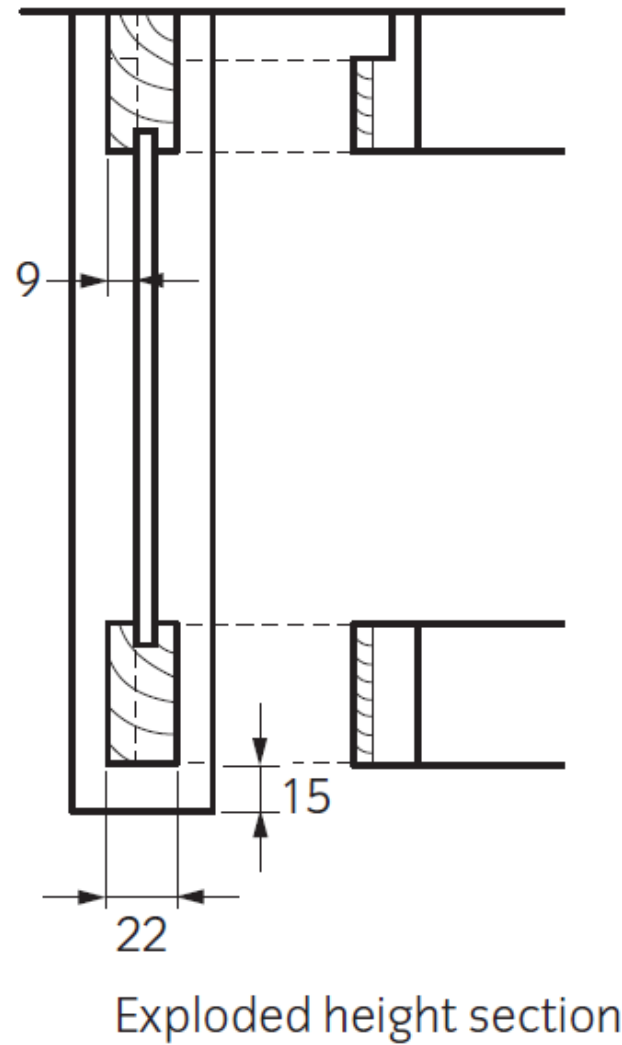
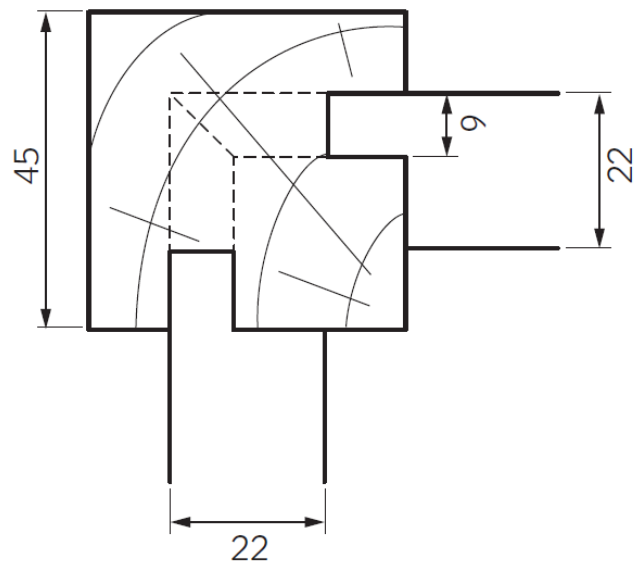
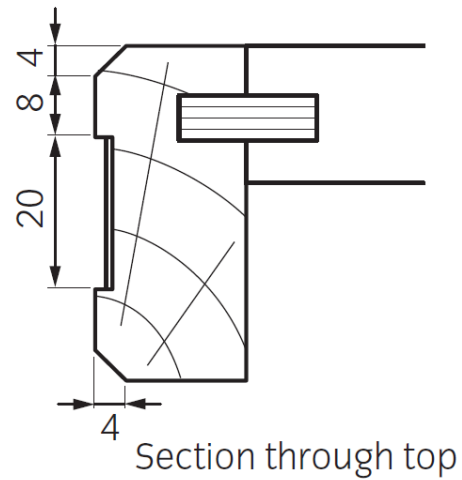

Drawings and diagrams

Unit 241 Manufacture external shopfitting joinery products

Task 1 Set out a shopfront

Task 2 Manufacture, assemble and finish a shopfront

Figure 1: Front elevation and section details of shopfront

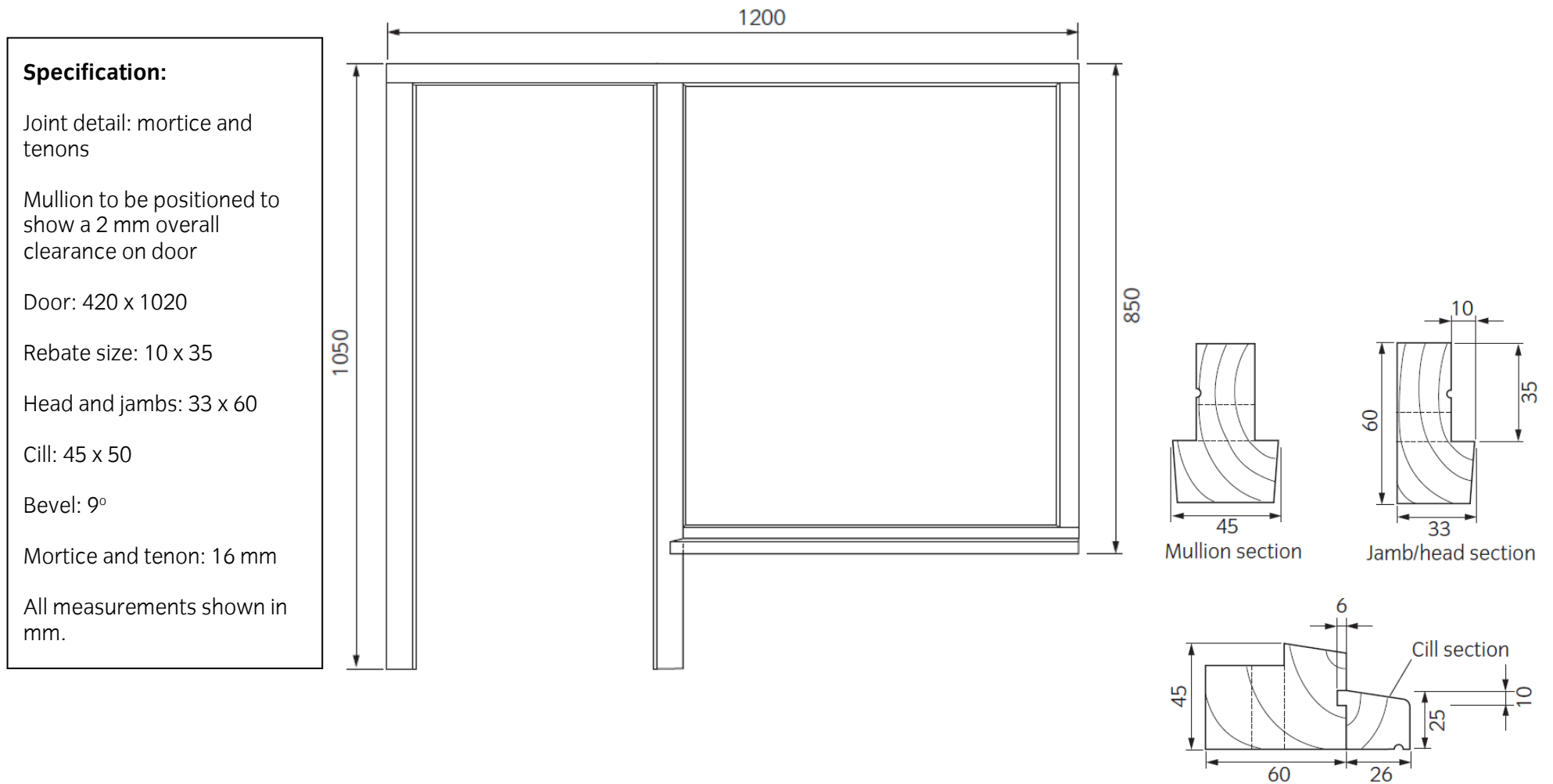

Published by City & Guilds
1 Giltspur Street
London
EC1A 9DD
T +44 (0)844 543 0000
F +44 (0)20 7294 2413
www.cityandguilds.com

**City & Guilds is a registered charity
established to promote education
and training**

About City & Guilds

As the UK's leading vocational education organisation, City & Guilds is leading the talent revolution by inspiring people to unlock their potential and develop their skills. We offer over 500 qualifications across 28 industries through 8500 centres worldwide and award around two million certificates every year. City & Guilds is recognised and respected by employers across the world as a sign of quality and exceptional training.

City & Guilds Group

The City & Guilds Group operates from three major hubs: London (servicing Europe, the Caribbean and Americas), Johannesburg (servicing Africa), and Singapore (servicing Asia, Australia and New Zealand). The Group also includes the Institute of Leadership & Management (management and leadership qualifications), City & Guilds Land Based Services (land-based qualifications), the Centre for Skills Development (CSD works to improve the policy and practice of vocational education and training worldwide) and Learning Assistant (an online e-portfolio).

Copyright

The content of this document is, unless otherwise indicated, © The City and Guilds of London Institute and may not be copied, reproduced or distributed without prior written consent. However, approved City & Guilds centres and candidates studying for City & Guilds qualifications may photocopy this document free of charge and/or include a PDF version of it on centre intranets on the following conditions:

- centre staff may copy the material only for the purpose of teaching candidates working towards a City & Guilds qualification, or for internal administration purposes
- candidates may copy the material only for their own use when working towards a City & Guilds qualification

The *Standard Copying Conditions* (see the City & Guilds website) also apply.

Published by City & Guilds, a registered charity established to promote education and training

Every effort has been made to ensure that the information contained in this publication is true and correct at the time of going to press. However, City & Guilds' products and services are subject to continuous development and improvement and the right is reserved to change products and services from time to time. City & Guilds cannot accept liability for loss or damage arising from the use of information in this publication.