

Automotive Qualifications (4101)

Practical assessment guide

Certificate in Vehicle Maintenance and Repair

VRQ Level 1



About City & Guilds

City & Guilds is the UK's leading provider of vocational qualifications, offering over 500 awards across a wide range of industries, and progressing from entry level to the highest levels of professional achievement. With over 8500 centres in 100 countries, City & Guilds is recognised by employers worldwide for providing qualifications that offer proof of the skills they need to get the job done.

City & Guilds Group

The City & Guilds Group includes City & Guilds, ILM (the Institute of Leadership & Management) which provides management qualifications, learning materials and membership services, NPTC which offers land-based qualifications and membership services, and HAB (the Hospitality Awarding Body). City & Guilds also manages the Engineering Council Examinations on behalf of the Engineering Council.

Equal opportunities

City & Guilds fully supports the principle of equal opportunities and we are committed to satisfying this principle in all our activities and published material. A copy of our equal opportunities policy statement *Access to assessment and qualifications* is available on the City & Guilds website.

Copyright

The content of this document is, unless otherwise indicated, © The City and Guilds of London Institute 2007 and may not be copied, reproduced or distributed without prior written consent.

However, approved City & Guilds centres and learners studying for City & Guilds qualifications may photocopy this document free of charge and/or include a locked PDF version of it on centre intranets on the following conditions:

- centre staff may copy the material only for the purpose of teaching learners working towards a City & Guilds qualification, or for internal administration purposes
- learners may copy the material only for their own use when working towards a City & Guilds qualification
- the *Standard Copying Conditions* on the City & Guilds website.

Please note: National Occupational Standards are not © The City and Guilds of London Institute. Please check the conditions upon which they may be copied with the relevant Sector Skills Council.

Publications

City & Guilds publications are available on the City & Guilds website or from our Publications Sales department at the address below or by telephoning +44 (0)20 7294 2850 or faxing +44 (0)20 7294 3387.

Every effort has been made to ensure that the information contained in this publication is true and correct at the time of going to press. However, City & Guilds' products and services are subject to continuous development and improvement and the right is reserved to change products and services from time to time. City & Guilds cannot accept liability for loss or damage arising from the use of information in this publication.

City & Guilds

1 Giltspur Street

London EC1A 9DD

T +44 (0)20 7294 2800

F +44 (0)20 7294 2400

www.cityandguilds.com

enquiry@cityandguilds.com

Automotive Qualifications (4101)

Practical assessment guide



www.cityandguilds.com
March 2007
Version 1.0

This page is intentionally blank

Contents

1	About this document	5
2	Guidance for assessors	6
3	Resource requirements	10
4	Guidance for candidates	11
5	Candidate information sheet	12
6	Assessment pro formas	13
6.1	Note for assessors	13
6.2	Portfolio reference number (PRN) tracking table	14
6.3	Portfolio reference number (PRN) unit table	15
6.4	PRN 1 Good housekeeping: Tools used, cleaned, checked and stored for subsequent use	16
6.5	PRN 2 Operate and assess a range of vehicle tools and equipment	17
6.6	PRN 3 Make a simple tool	18
6.7	PRN 3 Make a simple tool (continued)	19
6.8	PRN 4 Simple vehicle electrics	20
6.9	PRN 5 Carry out a basic routine service	21
6.10	PRN 6 Valet vehicle	22
6.11	PRN 7 Pre-work	23
6.12	PRN 8 Post-work	24

This page is intentionally blank

1 About this document

This assignment guide has been designed to cover the most popular automotive maintenance and repair units for the City & Guilds VRQ Level 1 Certificate in Vehicle Maintenance and Repair (4101). It can be used for **light vehicle** (LV), **heavy vehicle** (HV), **motorcycle** (MC) and **vehicle valeting** practical assessments and applies to the following qualification routes:

Vocationally Related Qualification (VRQ) routes

VRQ complexes	VRQ unit title
4101-45	Level 1 Certificate in Vehicle Maintenance and Repair
4101-96	Level 1 Certificate in Vehicle Maintenance and Repair (Vehicle Valeting)

2 Guidance for assessors

Introduction

The assessments have been designed to cover all the scope, observation and knowledge requirements for the practical content of this qualification.

Underpinning knowledge for each practical assessment should be covered during the assessment and documented on the worksheets provided within this guide. Candidates are required to complete a number of practical tasks to show their attainment of practical skills and underpinning knowledge.

One practical task may cover elements from more than one unit. The practical tasks have been designed to avoid repetition, but allow complete coverage of the required knowledge for the qualification.

The practical assessments cover the most popular optional units. If a candidate wishes to cover units not contained within the tasks provided, the centre delivering the qualification will need to devise the appropriate practical task. For further information on centre devised assignments please refer to the 4101/4121 qualification handbook, section 5.12 *Producing centre devised assignments*, available from the City & Guilds Automotive website (www.cityandguilds.com/uk/automotive).

Online testing (GOLA) is used to assess the theory component of the vehicle maintenance and repair units. In addition to obtaining centre approval, centres are required to set up a GOLA profile in order to offer online examinations to candidates. Setting up a GOLA profile is a simple process that need only be completed once for the centre.

Details of how to set up the profile are available on the City and Guilds website (www.cityandguilds.com/gola). The website also has details of the GOLA helpline for technical queries and downloads for centres and candidates about GOLA examinations.

Note: It is important that candidates who are new to the industry complete a practical training programme which covers a wider range of equipment and resource material before attempting these final assessment tasks. This is to ensure that they gain the sufficient confidence and knowledge to successfully complete the qualification. For complimentary practical practice tasks please refer to the *Practical practice task guide* available for download from the City and Guilds Automotive website (www.cityandguilds.com/uk/automotive). For further information about available documentation and resources, please refer to section 1.2 *Other documents and sources of further information* in the qualification handbook.

Relation to Key Skills, Wider Key Skills and Core Skills

The City & Guilds VRQ Level 1 Certificate may provide opportunities to gather evidence if working towards any of the following Key Skills, Wider Key Skills or Core Skills: Communication; Number; ICT; Problem Solving; Improving Own Learning and Working with Others.

Examples of Key Skill, Wider Key Skill and Core Skill work are provided in the following table.

Key Skill/Wider Key Skill	Example of Key Skill work
Communication	Data collection, assessment, reports (oral and written), feedback.
Number	Measurements, percentages, test readings, pressures.
ICT	Computer diagnostics, data collection.
Problem Solving	Most assessments involve diagnosing vehicle problems and faults, although these are not in-depth at Level 1.
Working with Others	Working as teams to lift and support vehicle components is part of a vehicle technician's normal role, as well as during the assessments.
Improving Own Learning	Unit by unit achievements evidence the learning progress made by candidates during the assessment period.

A detailed guide to signposting the Key Skills, Wider Skills and Core Skills covered within this Level 1 qualification is outlined in the individual Vehicle Maintenance and Repair unit specifications available from the City & Guilds Automotive website (www.cityandguilds.com/uk/automotive).

Candidates seeking to achieve any of the Key Skills, Wider Key Skills and/or Core Skills would need to be separately registered for them. Any evidence presented for a Key/Core Skills and/or Wider Key Skills portfolio **must** be separately assessed using the relevant Key/Core and Wider Key Skills specifications and guidance. For further guidance and information about these qualifications, please refer to the City & Guilds website (www.cityandguilds.com).

Introducing practical tasks to candidates

It will be beneficial to take the candidate through what is required for each practical task and the way each task will be assessed.

Timings for practical tasks

A submission schedule should be worked out by the centre, governed by the overall assessment plan for the course, to be negotiated between the tutor/assessor and candidate.

The relationship between course delivery, the handing-out and completion of practical tasks are matters for agreement between the tutors and candidates locally.

Feedback

Assessors must provide feedback on every occasion that a skills observation takes place. Recording forms are provided and can be downloaded from the City & Guilds website (www.cityandguilds.com/uk/automotive).

Candidate's records of coursework

Candidates should be encouraged to keep their work carefully in a portfolio. This may be an unfamiliar form of record keeping for many candidates, but it is a good discipline which will benefit them when they progress in learning and training.

Overall grading of practical tasks

Practical tasks are graded Pass (P) or Fail (F).

Codes of practice

The importance of safe working practices, the demands of any regional and/or national legislation relating to health and safety and any regional and/or national codes of practice associated with the industry must always be adhered to.

Health and safety

The requirement to follow safe working practices is an integral part of City & Guilds qualifications and assessments, and it is the responsibility of centres to ensure that all relevant health and safety requirements are in place before the candidates start practical assessments.

Should a candidate fail to follow health and safety practice and procedures during an assessment, the assessment must be stopped and the candidate advised of the reasons why. The candidate should be informed that they have not reached the standard of assessment required. Candidates may retake the assessment at a later date, at the discretion of the centre.

If the centre is in any doubt about a violation of health and safety, guidance should be sought from the external verifier.

Guidance on risk management of pre-16 candidates

Centres offering the City & Guilds Automotive qualifications at Level 1 to candidates under the age of 16 must assume responsibility for the safe delivery of the qualification. This will include those units that require using and working with power tools and machinery and using and working under lifts and hoists.

Verification of practical tasks

By using checklists, verifiers can check that evidence for an assignment is complete and can ensure that the assessment decision has been fair and beyond dispute.

Assessors must ensure that candidates understand why a particular grade has been given for the task. It is for this reason that City & Guilds requires the signature of both the assessor and the candidate on the assignment record.

If a candidate's work is selected for verification, samples of work must be made available to the appointed external verifier. The external verifier will ensure that:

- the internal verifier is undertaking his/her responsibilities
- the internal verifier is given prompt, accurate and constructive feedback on centre operations
- a report is written on centre activities for City & Guilds.

Internal quality assurance

Approved centres must have effective quality assurance systems to ensure optimum delivery and assessment of qualifications.

Quality assurance includes initial centre approval, qualification approval and the centre's own internal procedures for monitoring quality. Centres are responsible for internal quality assurance, and City & Guilds is responsible for external quality assurance.

Full details and guidance on the internal and external quality assurance requirements and procedures, are provided in *Providing City & Guilds qualifications – A guide to centre and qualification approval* (available from www.cityandguilds.com, by selecting 'becoming a centre'). This document also explains the tasks, activities and responsibilities of quality assurance staff.

In order to fully support candidates, centres are required to retain copies of candidates' assessment records for three years after certification.

Centres are also free to design their own practical tasks, if they feel their suggestions better reflect candidate and/or regional/national needs, or if the chosen route is not covered by the tasks provided by City & Guilds. Nationally/regionally-devised tasks must fulfill the assessment requirements of each unit.

Entry for assessment and certification

Candidates should be registered via the Walled Garden or using Form S at least 28 days before any assessment. Entries for the online multiple choice test should be made via the Walled Garden or by using Form S as per the instructions outlined in *Providing City & Guilds qualifications – A guide to centre and qualification approval*.

Results of assignments should be submitted in the form of grades via the Walled Garden or by using Form S. Only those units which have been achieved should be included. Each unit number is entered, followed by P (Pass) to indicate the grade the candidate has achieved.

3 Resource requirements

The resource list below identifies the typical workshop tools and equipment required to complete the City & Guilds VRQ Level 1 Certificate in Vehicle Maintenance and Repair (4101). This list is not comprehensive, and additional tools and consumables; such as oil, filters, polish, cloths and buffers, will be required to complete the Vehicle Valeting Certificate (4101-96).

- Steel ruler.
- Micrometer (25 millimetre and 50 millimetre).
- Oil drain.
- Vernier calliper.
- Trolley jack, wheel chocks and stands.
- Dial test indicator.
- Antifreeze tester.
- Hand and pillar drill.
- Torque wrench.
- Air wrench.
- Taps and dies.
- Multimeter (volts, amps and ohm).
- Bulbs, circuit boards, wire and connectors.
- Battery/power source.
- Wheel alignment gauge.
- Engine diagnostic machine with gas analyser.
- Straight edge.
- Vee blocks and surface plate.
- Brake fluid test machine.
- Selection of hand tools suitable for a garage workshop.
- Selection of gauge consumables (rags, nuts, bolts, washers, electrical terminals).

4 Guidance for candidates

The practical tasks given to you by your tutor have been designed to help you to complete the City & Guilds VRQ Level 1 Certificate in Vehicle Maintenance and Repair (4101).

The following will help you to understand the requirements of the practical assessment and ensure that you complete all of the necessary recording forms.

- 1 Before starting the assessment it is important that you have had sufficient training.
- 2 Read the task criteria carefully and complete **all** parts of the assessment task.
- 3 Complete **all** the documentation as neatly and as legibly as possible.
- 4 Try to keep to the estimated times allowed.
- 5 Ensure that you and your assessor sign and date the relevant worksheets accurately, and that you get feedback from your assessor.

5 Candidate information sheet

Candidate name:
Date of Birth:
Date enrolled with centre:
Date enrolled with City & Guilds:
City & Guilds enrolment number:
Course tutor:

6 Assessment pro formas

6.1 Note for assessors

Before the G1-V1 and V76 units are awarded, sufficient evidence needs to be achieved. For the purpose of this assessment booklet, these units are embedded within the following main units: MR05-V19; MR09-V24 and MR12-V27. All the criteria for the **performance, knowledge** and **scope** have also been embedded within the unit tasks. It is important that this task documentation is completed fully and correctly.

Unit Number	Unit Title	Scope (please tick)	Observation (please tick)	Knowledge (please tick)	Unit description And portfolio/page number (PRN)	Assessor signature	Date			
G1-V1	Contribute to good house Keeping				Units G1-V1 and V76 are generic units and can be completed as stand alone units. However, for the purpose of this assessment package, they are integrated within the main core units as listed below. Once the main core units are completed, they can be automatically signed off. PRN 1 Contribute to workplace good house keeping PRN 2 Operate and assess a range of vehicle tools and equipment PRN 3 Make a simple tool PRN 4 Simple vehicle electronics					
V76	Introduction to vehicle technology and workshop methods and processes									
V77	Carry out basic routine service				PRN 5 Carry out a basic service					
MR09-V24	Valet vehicle (inside and exterior)				PRN 6 Valet vehicle					
MR05-V19	Conduct pre and post vehicle inspections				PRN 7 Pre work					
					PRN 8 Post work					
					Verifier sampling Name:..... Signature:.....					

6 Assessment pro formas

6.2 Portfolio reference number (PRN) tracking table

The table below identifies the PRN assessment pro formas that need to be completed to meet the required performance evidence for the relevant vehicle maintenance and repair units within the City & Guilds VRQ Level 1 Certificate in Vehicle Maintenance and Repair (4101). The assessment pro formas follow this page. For a detailed qualification structure please refer to the *Qualification handbook – section 5.3 VRQ Route tables*.

G1-V1	Contribute to workplace good housekeeping																
Criteria	Hand tools	Electrical tools	Mechanical tools	Pneumatic tools	Hydraulic tools												
PRN	1,2,3,4,5	1, 6	1,2,3,4,5,6	1,6	1,6												
V76	Introduction to vehicle technology and workshop methods and processes				Routine checks on tools			Make a simple tool		Recognise, assess, tools, components and equipment							
	Operate a range of vehicle equipment as follows:																
	Electrical	Mechanical	Pneumatic	Hydraulic													
PRN	1,3,6,7	1,2,6,	1,6	1,6,8,9	1,6,3,5			3		1,3,4,5,6,7,8,9							
V77	Carry out basic routine service																
Criteria	Fuel system	Lubrication	Cooling	Ignition	Transmission driveline	Steering	Suspension wheels tyres	Brakes	Electrical electronic lights	Data collection	Health and safety risks Spillages	Wear capacity levels					
PRN	5	5	5	5	5	5	5	5	5	5	5	5					
MR09-V24	Valet vehicles (inside and exterior)																
Criteria	Wash tools	Polish tools	Vacuum tools	Hand tools	Spray wax	Chemical use	Tyre and wheel dress	glass	Plastic and rubber	Hard and Soft trim	PPE	Customer valuables	Disposal	Follow policy	Delay times	Store equipment materials	Follow policy legislation procedure
PRN	6	6	6	6	6	6	6	6	6	6	6	6	6	6	6	6	6
MR05-V19	Conduct pre and post vehicle inspections																
Criteria	Pre-work inspection	Post-work inspection	PPE	Technical data	Health and safety procedures	Checks against vehicle specifications	Vehicle protection	Make recommendations	Accurate records	Delays and times	Reports actions needed						
PRN	8,9	8,9	8,9	8,9	8,9	8,9	8,9	8,9	8,9	8,9	8,9						

6 Assessment pro formas





6.3 Portfolio reference number (PRN) unit table

The table below identifies the units covered and the corresponding portfolio reference number (PRN) for each assessment pro forma contained within this guide.

PRN	Name	Units covered
1	Good housekeeping: Tools used, cleaned, checked and stored for subsequent use	G1-V1
2	Operate and assess a range of vehicle tools and equipment	G1-V1, V76
3	Make a simple tool	G1-V1, V76
4	Simple vehicle electrics	G1-V1, V76
5	Carry out a basic routine service	G1-V1, V77
6	Valet vehicle	G1-V1, MR09-V24
7	Pre-work	G1-V1, MR05-V19
8	Post-work	G1-V1, MR05-V19

6 Assessment pro formas

6.4 PRN 1 Good housekeeping: Tools used, cleaned, checked and stored for subsequent use

Date work carried out/...../.....		Indicate unit(s) covered on this evidence record:		G1-V1					
<ul style="list-style-type: none"> Produce evidence of good housekeeping Show you can check tools for damage Clean tools Store tools Clean work area 									
<p>This will form part of your normal workshop duties and you will need to show consistently that this is taking place to achieve this unit.</p>									
HAND TOOLS		HYDRAULIC TOOLS		ELECTRICAL TOOLS		PNEUMATIC TOOLS		MECHANICAL TOOLS	
Tool box checks		Car lifts		Drill		Air gun/wrench		Pullers	
Spanners		Trolley jack		Grinder		Air drill		Vice	
Screwdriver		Bottle jack		Hand lamp		Air lines		Press	
Socket sets		Other		Other		Tyre machine		Other	
Assessor initial:.....		Assessor initial:.....		Assessor initial:.....		Assessor initial:.....		Assessor initial:.....	
<p>Work found that requires further attention and any action taken – Identify tools, identify damage and keep a record:</p>									
<p>Clean work area Assessor to sign this when observations of cleaning the work area have taken place to the required standard over a period of time.</p>									
<p>Start date:...../...../..... End date:/...../.....</p>									
<p>Assessor knowledge check – outline of question(s) used and response:</p>									
<p>Assessor feedback on evidence provided:</p>									
<p>I confirm that the work carried out on this evidence record meets City & Guilds requirements for validity, authenticity, currency and sufficiency. All the necessary scope, performance and knowledge for this task have been met.</p>									
Assessor name:.....			Signature:			Date:...../...../.....		Candidate signature:.....	
								Date:...../...../.....	

6 Assessment pro formas

6.5 PRN 2 Operate and assess a range of vehicle tools and equipment

Date work carried out / /		Indicate unit(s) covered on this evidence record:		G1-V1	V76						
Operate and assess a range of vehicle tools and equipment (this can be over a period of time such as an academic year)											
 Oil drain	 Post lift	 Post lift	 Air wrench	Antifreeze tester							
 Tyre changer	 Tyre inflation	 Axle stand.....	 Car lift/jack	Drill							
 Bench grinder	 Exhaust extraction	 Crane sling	 (Basic operation only) Welding equipment	Jacking beam							
This is a selection of the main equipment that a garage mechanic should be familiar with and has knowledge to check, operate, and use in a safe and proper manner.											
When the candidate has been assessed meeting the above criteria, sign off this task sheet.											
I confirm that the work carried out on this evidence record meets City & Guilds requirements for validity, authenticity, currency and sufficiency. All the necessary SCOPE, PERFORMANCE, KNOWLEDGE for this task have been met.											
Assessor name:.....			Signature:		Date: / /		Candidate signature:.....			Date:.... / /	





6 Assessment pro formas

6.6 PRN 3 Make a simple tool

Date work carried out / /		Indicate unit(s) covered on this evidence record:		G1-V1	V76					
State the purpose of the tool:			Make a simple tool (estimated time 8 hours)							
		This task is about making a simple tool. Candidates are expected to be able to cut materials, measure, mark out, file, drill, thread and use joining methods.								
Cut material	Measure material	Mark out material	File	Drill	Make threads	Join materials				
Assessor initial:.....	Assessor initial:.....	Assessor initial:.....	Assessor initial:.....	Assessor initial:.....	Assessor initial:.....	Assessor initial:.....	Assessor initial:.....			
Specific evidence of health and safety, good housekeeping and working with others:										
1	Able to work in a safe and proper manner		3	Tools tidy, cleaned, checked and put away		5	Wear and use correct PPE			
2	Dispose of all waste correctly and safely		4	Identify and be able to work to workshop policies						
Candidate to write a short explanation on how the tool was produced:										
Assessor feedback from questions and observation:										
When the candidate has been assessed meeting the above criteria, sign off this task sheet.										
I confirm that the work carried out on this evidence record meets City & Guilds requirements for validity, authenticity, currency and sufficiency. All the necessary scope , performance and knowledge for this task have been met.										
Assessor name:.....			Signature:		Date: / /		Candidate signature:.....		Date:.... / /	



6 Assessment pro formas

6.7 PRN 3 Make a simple tool (continued)

Make a simple tool		G1-V1	V76				
Examples only of what can be done							
							
Brake tool	Brake pipe tool	Oil filter chain					
							
Oil filter strap wrench							

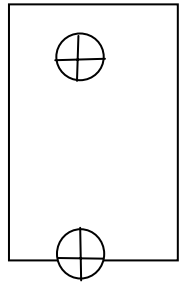
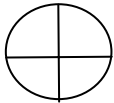
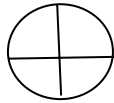
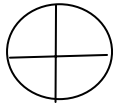

6 Assessment pro formas

6.8 PRN 4 Simple vehicle electrics

Date work carried out/...../.....	Indicate unit(s) covered on this evidence record:	V76	G1-V1									
Vehicle details Vehicle type (please circle) LV HGV MC PSV Make/Model Registration number Chassis/VIN number		<ul style="list-style-type: none"> Build a simple parallel circuit and take measurements Measure vehicle thermister resistance (coolant sensor) Check battery voltage on vehicle 										
Details of work activity: Adjust to suit vehicle types		1) Build a simple PARALLEL circuit with power source, three bulbs, and leads. Take measurements for voltage and current. 2) Measure a coolant temperature sensor and record resistance reading. 3) Check battery voltage.										
Complete the diagram. Use a pencil and draw in wires and electrical test meters. Once complete, build a simple circuit and take voltage and current readings.												
 Battery	 bulb 1	 bulb 2	 bulb 3	<table border="1" style="margin-left: auto; margin-right: auto;"> <tr> <td style="text-align: center;">Table</td> </tr> <tr> <td>Battery voltage</td> </tr> <tr> <td>Voltage across bulb 1</td> </tr> <tr> <td>Voltage across bulb 2</td> </tr> <tr> <td>Voltage across bulb 3</td> </tr> <tr> <td>Current in circuit</td> </tr> </table>			Table	Battery voltage	Voltage across bulb 1	Voltage across bulb 2	Voltage across bulb 3	Current in circuit
Table												
Battery voltage												
Voltage across bulb 1												
Voltage across bulb 2												
Voltage across bulb 3												
Current in circuit												
	Check resistance and record the reading			Use voltmeter and record battery voltage								
Assessor knowledge check – outline of question(s) used and response:												
Assessor feedback on evidence provided:												
I confirm that the work carried out on this evidence record meets City & Guilds requirements for validity, authenticity, currency and sufficiency. All the necessary scope , performance and knowledge for this task have been met.												
Assessor name:.....		Signature:		Date:/...../.....		Candidate signature:.....		Date:...../...../.....				

6 Assessment pro formas

6.9 PRN 5 Carry out a basic routine service

Date work carried out/...../.....		Indicate unit(s) covered on this evidence record:		G1-V1	V77						
Vehicle details Vehicle type (please circle) LV HGV MC PSV Make/Model Registration number Chassis/VIN number				Carry out a basic routine service (estimated time: 2 hours)   							
Details of work activity: Adjust to suit vehicle types	Fan belt/alternator belt	Air filter checks	Ignition checks	Suspension and steering checks	Under bonnet levels						
	Brakes check front/rear	Tyre check	Interior systems check	Lighting systems	Battery checks						
Change oil and filter	Under body damage	Exhaust gas test	Ancillary electrical checks	Transmission oils	Exterior body damage						
Special tools/equipment used: Hydraulic lifting equipment Hand tools Tyre pressure tester Antifreeze tester Voltmeter Torque & air wrench Gas analyser		Technical information: Tyre pressures Engine oil capacity Wheel nut torque CO/HC if applicable..... Minimum brake pad limit		Examination and testing methods used (include readings as appropriate): Brake fluid level Brake pad wear CO / HC reading if applicable..... Antifreeze frost protection Battery voltage							
Specific evidence of health and safety, good housekeeping and working with others:											
1	Work with others to check lighting	4	Sweep up	7	Wear and use correct PPE.						
2	Dispose of all waste correctly and safely	5	Clear up spillages from oil changes								
3	Tools tidy, cleaned, checked and put away	6	Identify workshop policies								
Work found that requires further attention and any action taken:											
Assessor knowledge check:											
Assessor feedback on evidence provided:											
I confirm that the work carried out on this evidence record meets City & Guilds requirements for validity, authenticity, currency and sufficiency. All the necessary scope , performance and knowledge for this task have been met.											
Assessor name:.....			Signature:		Date:/...../.....		Candidate signature:.....			Date:...../...../.....	

6 Assessment pro formas

6.10 PRN 6 Valet vehicle

Date work carried out/...../.....		Indicate unit(s) covered on this evidence record:		MR09-V24	G1-V1		
Vehicle details Vehicle type (please circle) LV HGV MC PSV Make/Model Registration number Chassis/VIN number			Valet Vehicle – Interior and exterior (estimated time 2.5 hours)				
Details of work activity: Adjust to suit vehicle types			<ul style="list-style-type: none"> • Wash/power wash/steam: use detergents/chemicals as appropriate • Polish exterior • Vacuum and cover interior with covers • Clean all glass • Clean wheel and dress tyres with • Exterior plastic trim dressing. 				
Special tools/equipment used (please tick): Power hose/pressure wash Detergent/chemicals Vacuum Vehicle protection		Detergents, chemicals, polishes, waxes used: Body paintwork Glass Wheels/tyres Plastic trim		Examination and testing methods used (include readings as appropriate): Condition of paintwork Condition of interior Condition of wheels and tyres Condition of glass			
Specific evidence of health and safety, good housekeeping and working with others:							
1	Read regulations relating to substances hazardous to health	4	Sweep up	7	Wear and use correct PPE.		
2	Dispose of all waste correctly and safely	5	Care with detergents and chemicals				
3	Tools and equipment tidy, cleaned, checked and put away	6	Identify workshop policies				
Work found that requires further attention and any action taken. Identify vehicle damage and record:							
Assessor knowledge check – outline of question(s) used and response:							
Assessor feedback on evidence provided:							
I confirm that the work carried out on this evidence record meets City & Guilds requirements for validity, authenticity, currency and sufficiency. All the necessary scope, performance and knowledge for this task have been met.							
Assessor name:		Signature:		Date:/...../.....		Candidate signature:..... Date:...../...../.....	

6 Assessment pro formas

6.11 PRN 7 Pre-work

Date work carried out/...../.....		Indicate unit(s) covered on this evidence record:		G1-V1	MR05-V19					
Vehicle details: Vehicle type (please circle) LV HGV MC PSV Make/Model Registration number Chassis/VIN number				Pre-work (estimated time 1.5 hours)						
Details of work activity: Adjust to suit vehicle types		This task is about checking the vehicle and vehicle systems prior to work commencing. It is to ensure that the vehicle systems operate and that damage to both interior and external have been recorded								
Exterior report			Interior report			Lights	Wipers	Horn		
						Keys correct	Instruments	Seat belts		
						Customer belongings	Driver controls	Under bonnet		
Specific evidence of health and safety, good housekeeping and working with others:										
1	Work with others to check lighting	4	Conforms to specification	7	Wear and use correct PPE.					
2	Dispose of all waste correctly and safely	5	Vehicle protection							
3	Tools tidy, cleaned, checked and put away	6	Identify workshop policy							
Work found that requires further attention and any action taken:										
Assessor knowledge check:										
Assessor feedback on evidence provided:										
I confirm that the work carried out on this evidence record meets City & Guilds requirements for validity, authenticity, currency and sufficiency. All the necessary scope , performance and knowledge for this task have been met.										
Assessor name:.....			Signature:		Date:/...../.....		Candidate signature:.....			Date:...../...../.....

6 Assessment pro formas

6.12 PRN 8 Post-work

Date work carried out/...../.....		Indicate unit(s) covered on this evidence record:		G1-V1	MR05-V19			
Vehicle details Vehicle type (please tick) LV HGV MC PSV Make/Model Registration number Chassis/VIN number				Post-work (estimated time 1.5 hours)				
Details of work activity: Adjust to suit vehicle types		This task is about checking the vehicle and vehicle systems post - work. To ensure that the vehicle systems operate and that damage to both interior and external have been recorded.						
Exterior report		Interior report			Lights	Wipers	Horn	
					Keys correct	Instruments	Seat belts	
					Customer belongings	Driver controls	Under bonnet	
Specific evidence of health and safety, good housekeeping and working with others:								
1	Work with others to check lighting	4	Conforms to specification	7	Wear and use correct PPE.			
2	Dispose of all waste correctly and safely	5	Vehicle protection					
3	Tools tidy, cleaned, checked and put away	6	Identify workshop policies					
Work found that requires further attention and any action taken:								
Assessor knowledge check:								
Assessor feedback on evidence provided:								
I confirm that the work carried out on this evidence record meets City & Guilds requirements for validity, authenticity, currency and sufficiency. All the necessary scope, performance and knowledge for this task have been met.								
Assessor name:.....		Signature:		Date:/...../.....		Candidate signature:.....		Date:...../...../.....

This page is intentionally blank

Published by City & Guilds
1 Giltspur Street
London
EC1A 9DD
T +44 (0)20 7294 2468
F +44 (0)20 7294 2400
www.cityandguilds.com

City & Guilds is a registered charity
established to promote education
and training